



Code 80792B  
Edition 01-2025 (translation of original version)

### CONTENTS

<b>1. GENERAL PRECAUTIONS</b> .....	<b>2</b>
<b>2. TRANSMITTERS WITH AMPLIFIED DIGITAL OUTPUT</b> .....	<b>2</b>
2.1. <i>Standard installation (recommended)</i> .....	2
2.2. <i>Electrical connections</i> .....	3
2.3. <i>Interfaces with SRP/CS</i> .....	3
<b>3. TECHNICAL SPECIFICATIONS</b> .....	<b>4</b>
3.1. <i>EMC Tests performed for mobile hydraulic and automotive applications</i> .....	6
3.2. <i>EMC Tests performed for industrial applications</i> .....	7
<b>4. SAFETY MANUAL (for CANopen Safety transducers only)</b> .....	<b>8</b>
4.1. <i>Application</i> .....	8
4.3. <i>Restrictions of use</i> .....	9
4.4. <i>Periodic maintenance, testing and inspections</i> .....	9
4.5. <i>Indication of response time</i> .....	9
4.6. <i>Suspension of the safety function</i> .....	9
4.7. <i>Indications and alarms</i> .....	10
4.8. <i>Failures and troubleshooting</i> .....	11
4.9. <i>Safe Parameterization</i> .....	11
4.9.1. <i>Safe Communication Parameterization</i> .....	11
4.9.2. <i>Safe Application Parameterization</i> .....	12

# 1. GENERAL PRECAUTIONS

The system must be used only in accordance with the required protection level.

The sensor must be protected against accidental knocks and used in accordance with the instrument's ambient characteristics and performance levels.

Sensors must be powered with non distributed networks.

## 2. TRANSMITTERS WITH AMPLIFIED DIGITAL OUTPUT

**Transducers:** KMC series

**Outputs:** CANopen (\*), J1939, CANopen Safety (\*)

(\*) with CiA 404 Device Profile

### Installation remarks

- The transducer must be grounded (normally through the machine body or equipment it is installed on).
- To prevent interference, separate the power cables from the signal cables.

### 2.1. Standard installation (recommended)

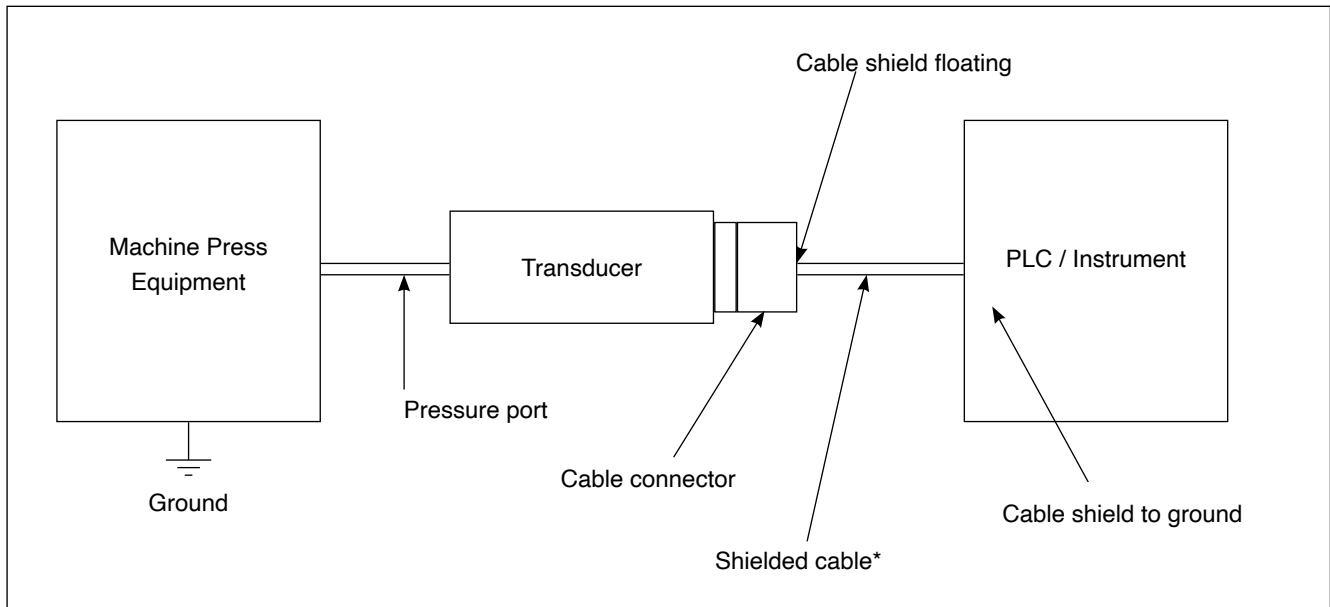

- \*Shielded cable advised for  $L > 30$  m

- In case of use of a shielded cable, the cable shield must be grounded on PLC side and left floating on machine side (on M12 electrical connector it's possible to connect the shield on machine side by leaving floating the PLC side).

## 2.2. Electrical connections

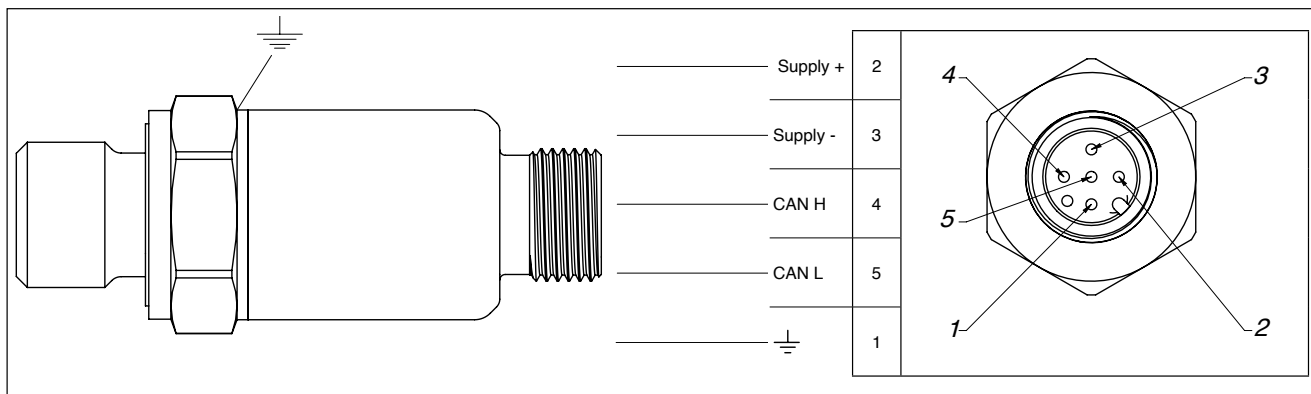

## 2.3. Interfaces with SRP/CS

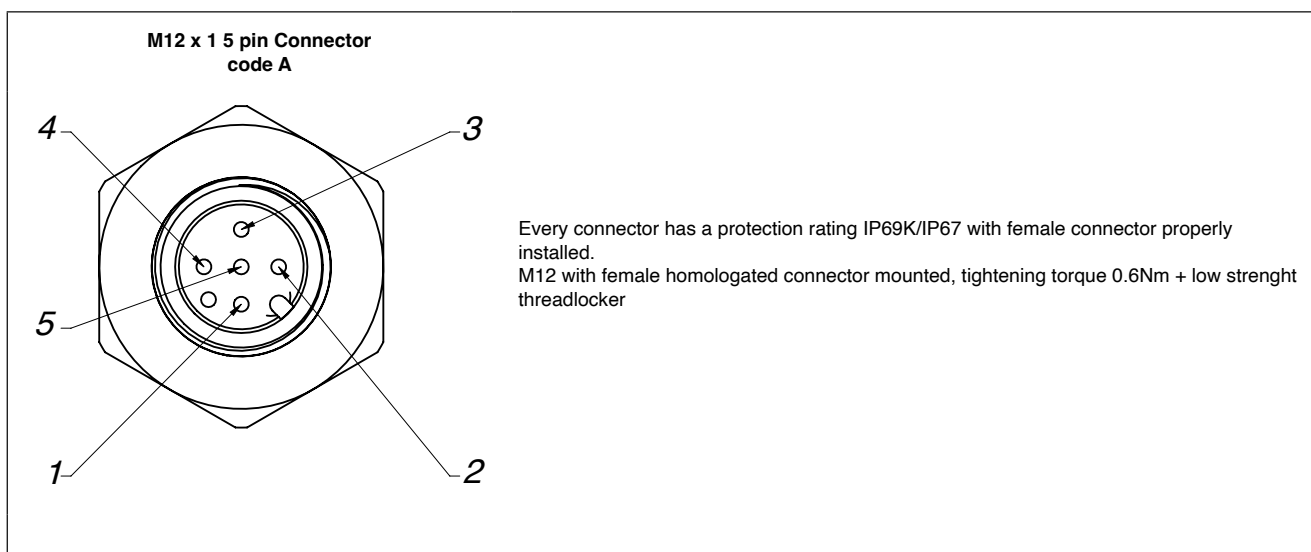

### 3. TECHNICAL SPECIFICATIONS

<b>Non Linearity (BFSL)</b>	± 0.15% FS (typ); ± 0.25% FS (max)
<b>Hysteresis</b>	+ 0.1% FS (typ); + 0.15% FS (max)
<b>Repeatability</b>	± 0.025% FS (typ); ± 0.05% FS (max)
<b>Zero offset tolerance</b>	± 0.15% FS (typ); ± 0.25% FS (max)
<b>Span offset tolerance</b>	± 0.15% FS (typ); ± 0.25% FS (max)
<b>Accuracy at room temperature (1)</b>	< ± 0.5% FS
<b>Pressure ranges (2)</b>	From 4 bar to 1000 bar (See table)
<b>Overvoltage</b>	36 Vdc continuous 48 Vdc according to ISO7637-2 Pulse 5
<b>Insulation voltage</b>	500 Vdc
<b>Overpressure (without degrading performance)</b>	See table
<b>Pressure containment (burst test)</b>	See table
<b>Pressure Media</b>	Fluids compatible with Stainless Steel AISI 430F and 17-4 PH
<b>Housing</b>	Stainless Steel AISI 304
<b>Long term stability (accuracy)</b>	<0,2%FS per year (within compensated temperature range -20...+85 °C and nominal pressure range)
<b>Operating temperature range (process)</b>	-40...+125 °C (-40...+257 °F)
<b>Operating temperature range (ambient)</b>	-40...+125 °C (-40...+257 °F)
<b>Compensated temperature range</b>	-20...+85 °C (-4...+185 °F)
<b>Storage temperature range</b>	-40...+125 °C (-40...+257 °F)
<b>Temperature effects over compensated range (zero)</b>	± 0.01% FS/°C typ (± 0.02% FS/°C max.)
<b>Temperature effects over compensated range (span)</b>	± 0.01% FS/°C typ (± 0.02% FS/°C max.)
<b>Frequency measure</b>	4 kHz
<b>Response time (10...90%FS)</b>	3 ms CANopen, J1939 - 6 ms CANopen Safety
<b>Warm-up time (3)</b>	< 30 s.
<b>Mounting position effects</b>	Negligible
<b>Humidity</b>	Up to 100%RH non-condensing
<b>Weight</b>	50 g nominal
<b>Mechanical shock</b>	100 g 6 ms according to IEC 60068-2-27 50 g 11 ms according to ISO 19014-3
<b>Vibrations</b>	20g max at 10...2000 Hz according to IEC 60068-2-6 Random ASD 10...2000 Hz according to ISO 19014-3
<b>Ingress protection</b>	IP67/IP69K with female homologated connector mounted
<b>Output short circuit and reverse polarity protection</b>	YES

FS = Full scale

- 1) Incl. Non-Linearity, Hysteresis, Repeatability, Zero-offset and Span-offset tolerance (acc. to IEC 62828-2)
- 2) The operating pressure range is intended from 0.5 to 100% FS; sensor is relative, so the 'bar indication is always meant to be barg
- 3) Time within which the rated performance is achieved
- 4) See possible restrictions in the paragraphs "Electrical connections" and "Accessories on request".

<b>RANGE (Bar)</b>	<b>4</b>	<b>6</b>	<b>10</b>	<b>16</b>	<b>20</b>	<b>25</b>	<b>40</b>	<b>60</b>	<b>100</b>	<b>160</b>	<b>200</b>	<b>250</b>	<b>400</b>	<b>600</b>	<b>1000</b>
Overpressure (Bar)	8	12	20	32	40	50	80	120	200	320	400	500	800	1200	1200
Burst pressure (Bar)	16	24	40	64	80	100	160	240	400	640	800	1000	1500	1500	1500

<b>EMC compliance according to: Standard / Directive /Regulation</b>	<b>Title</b>
<b>2014/30/EU</b>	EMC Directive (Electromagnetic compatibility)
<b>ISO 13766-1:2018</b>	Earth-moving and building construction machinery – Electromagnetic compatibility (EMC) of machines with internal electrical power supply – Part 1: General EMC requirements under typical electromagnetic environmental conditions
<b>ISO 13766-2:2018 (*)</b>	Earth-moving and building construction machinery – Electromagnetic compatibility (EMC) of machines with internal electrical power supply – Part 2:Additional EMC requirements for functional safety
<b>2015/208/UE</b>	COMMISSION DELEGATED REGULATION (EU) 2015/208 of 8 December 2014 supplementing Regulation (EU) No 167/2013 of the European Parliament and of the Council with regard to vehicle functional safety requirements for the approval of agricultural and forestry vehicles
<b>ECE ONU R10 (Rev 6)</b>	Uniform provisions concerning the approval of vehicles with regard to electromagnetic compatibility

(\*) Only applicable to SIL2/PL d certified models

See further details on Declaration of conformity and User Manual

### 3.1. EMC Tests performed for mobile hydraulic and automotive applications

Test name	Test parameter			ECE R10	EN 14982	2015/208/EU Art. 19, An. XV	EN 13766-1	ISO 13766-2
Broadband radiated emission	30-75 MHz, 64-54 dB $\mu$ V/m 75-400 MHz, 54-65 dB $\mu$ V/m 400-1000 MHz, 65 dB $\mu$ V/m			X	X	X	X	NO REQ.
Narrowband radiated emission	30-75 MHz, 54-44 dB $\mu$ V/m 75-400 MHz, 44-55 dB $\mu$ V/m 400-1000 MHz, 55 dB $\mu$ V/m			X	X	X	X	X
Transient emission ISO 7637-2	Slow (12   24 V) Fast (12   24 V)	-75/+37V -112/+75V	-450/+37V -150/+150V	X	X	NO REQ.	X	NO REQ.
Immunity to RF disturbances ISO 11452-4	100 mA, 20-200 MHz (AM 1 kHz 80 %)			X	X	X	X	NO REQ.
Immunity to RF disturbances ISO 11452-2	30 V/m, 200-800 MHz. AM, H/V Pol. 30 V/m, 0,8-2 GHz, PM, H/V Pol. 100 V/m, 400-800 MHz, AM, H/V Pol. 100 V/m, 800-1000 MHz, PM, H/V Pol. 10 V/m, 2000-2400 MHz, PM, H/V Pol. 5 V/m, 2400-2700 MHz, PM, H/V Pol.			X	X	X	X	X
Immunity to RF disturbance ISO 11452-5	100 V/m, 0,01-400 MHz (AM 1 kHz 80 %) 200 V/m, 0,01-400 MHz (AM 1 kHz 80 %)			NO REQ.	NO REQ.	NO REQ.	NO REQ.	X
Electrostatic discharge	± 4,0 kV contact and air discharge ± 6,0 kV contact and air discharge ± 8,0 kV; 2k $\Omega$ /330pF contact discharge ± 8,0 kV; 2k $\Omega$ /330pF air discharge ± 15,0 kV; 2k $\Omega$ /330pF air discharge			NO REQ.	X	NO REQ.	X	X
Immunity to conducted transient on power supply line ISO 7637-2	1 2a 2b 3a 3b 4 5B	-75 V +37 +10 V -112 V +75 V -6 V +48V	-450 V +37 V 20 V -150 V +150 V -12 V +48V	X	X	NO REQ.	X	X
Immunity to conducted transient on supply lines ISO 16750-2	Starting profile	IV	IV	NO REQ..	NO REQ.	NO REQ.	X	X
Immunity to conducted transient on signal lines ISO 7637-3	3a 3b 1 (DCC) 2a (DCC) 1 (ICC) 2a (ICC)	-80 V, 10' +60 V, 10' -23 V, 5' +23 V, 5' -5 V, 5' +5 V, 5'	-110 V,10' +110 V,10' -35 V,5' +35 V,5' -8 V,5' +8 V,5'	NO REQ.	NO REQ.	NO REQ.	NO REQ.	X

### 3.2. EMC Tests performed for industrial applications

Gefran KMC products are tested also against industrial standard according to 2014/30/EU Directive (EMC):

- EN 61326-1 “Electrical equipment for measurement, control and laboratory use - EMC requirements - Part 1 general requirements”
- EN 61326-2-3 “Electrical equipment for measurement, control and laboratory use - EMC requirements - Part 2-3: Particular requirements - Test configuration, operational conditions and performance criteria for transducers with integrated or remote signal conditioning”

Emission requirements

Product is compliant to class A according to EN 55011

Immunity requirements

Port	Test name	Basic standard	Test parameter
Enclosure	Electrostatic discharge (ESD)	EN 61000-4-2	4/8 kV contact/air
	EM field	EN 61000-4-3	10 V/m (from 80 MHz to 1 GHz) 3 V/m (from 1,4 GHz to 2 GHz) 1 V/m (from 2,0 GHz to 6 GHz)
	Magnetic field	EN 61000-4-8	30 A/m
Power supply VDC	Burst	EN 61000-4-4	2 kV (5/50 ns, 5 kHz)
	Surge	EN 61000-4-5	1 kV/ 2 kV
	Conducted RF	EN 61000-4-6	3 V/m (from 150 kHz to 80 MHz)
I/O signa I/ control (including functional earth lines)	Burst	EN 61000-4-4	1 kV (5/50 ns, 5 kHz)
	Surge	EN 61000-4-5	1 kV
	Conducted RF	EN 61000-4-6	3 V (from 150 kHz to 80 MHz)

## 4. SAFETY MANUAL (FOR CANOPEN SAFETY TRANSDUCERS ONLY)

### 4.1. Application

The pressure sensor KMC CANopen Safety performs the following safety function:

Measurement and transduction of the read pressure value, with generation of a signal in CANopen Safety within the stated measurement uncertainty (see Sec. 4.2), for comparison with a fixed safety threshold-high threshold (comparison performed by downstream external system/controller).

The SIL/PL parameters of the transducer are shown in the table below:

Parameter	Value	Measuring Unit
Architecture	1oo1(D)	--
HFT	0	--
Category	2	--
$\beta$ factor	0,05	--
$\beta_D$ factor	0,02	--
$\lambda_{DD}$	6,55E-07	1/h
$\lambda_{DU}$	5,18E-08	1/h
DC <sub>avg</sub>	92,67	%
SFF	95,23	%
MTTF <sub>D</sub>	161,52	years
PFH	5,18E-08	1/h
Systematic Capability	2	--
SIL	2	--
PL	d	--

Three failure exclusions were considered in the evaluation:

- Wear/Corrosion of process mechanical components [13849-2:2012 prospectus A.4]
- Breakage of process mechanical components [13849-2:2012 prospectus A.4]
- Overstress deformation of process mechanical components [13849-2:2012 prospectus A.4]

The KMC CANopen Safety models can be used in:

- High Demand Mode for Machinery Industry applications
- Low Demand Mode for Process Industry applications

## 4.2. Effects on the safety function of performance deviations

The acceptability limit of metrological performance deviations in order not to induce loss of the safety function is  $\pm 5\%$  of the read value at room temperature

## 4.3. Restrictions of use

The device must only be used in accordance with these operating instructions for mechanical installation, electrical connection, environmental conditions and use in order to maintain the declared SIL/PL. The sensors must be powered by non-distributed networks and in any case with a length of less than 30 m.

The estimated failure rate of protocol is  $\lambda_{DU}=1,32E-11$  [1/h] (included in the failure rates listed in par. 4.1), considering that machine manufacturer applies proper control (according to EN 50325-5) at downstream controller, in terms of (for example):

- management of message redundancy
- management of data inversion
- management of timeout
- management of safe parameterization

## 4.4. Periodic maintenance, testing and inspections

The lifetime (mission time) of the pressure transmitters is 20 years

The failure rates stated in par. 4.1 are guaranteed for the declared lifetime, without the need of replacements of components or periodic tests of the safety functions.

No specific periodic maintenance activity is requested.

Notes:

- In order to maintain the correctness of measurement in the final application, the following visual inspections and related cleaning are recommended:
  - Check of the status of the electrical and mechanical connections
  - Check of possible obstruction of the channel under pressure (with removal of the probe from the process seat)
- Visual inspection frequency should be defined by the user according to real working conditions

## 4.5. Indication of response time

The response time to the pressure transduction is equal to 6 ms

The response time to failure is 500ms\*

\*except test on error in primary stage, on output stage and on logic (RAM, ROM, CPU), so the value is equal to 5s

Maximum network reaction time, according to the abovementioned response times, can be considered equal to 5s

## 4.6. Suspension of the safety function

No suspension or bypass of the safety function is possible.

## 4.7. Indications and alarms

The KMC CANopen Safety transducer detects specific anomalies and provide safety alarm output. The reaction to anomalies brings the output of safety function to Preoperational state, which means no communication of SRDO

Table 1 indicates the detected failures and their raw effect on output

Failure	Output
Power supply cable broken	Safe state Pre-Operational : no SRDO transmission
Sensor not connected	
Power supply broken	
Broken bridge	
Pressure over range (> 1,4x FS)*	
Pressure under range (<= -0,1X FS)*	
Error on primary or first amplification stage	
Overvoltage	
Undervoltage	
Error in the program sequence	
Overheating of the electronics	
RAM Error	
ROM/Flash Error	
CPU / Logic Error	
CAN output error (SRDO timer expired)	
CAN output error (SRDO config validation error)	
CAN output error (SR application objects validation error)	

\*Pressure values out of the expected range (according to the specific full scale, units and digits set) shall be treated accordingly as OUT OF RANGE values from the machine manufacturer

Each type of failure is also mapped and transmitted over an EMCY message (see Protocol User Manual for further definition cod. doc. 80795)

Moreover each type of failure is mapped inside the standard object "Manufacturer status register" (0x1002) which can be read through SDO protocol.

NOTE: A reset application command from Master will clear the indications above, allowing the application to be restarted; if the error condition is not removed, the error condition rises again. There are two types of failure whose indication is not cleared by a reset application. These types of failure are:

- Error in program sequence due to Watchdog expiration
- RAM Error

All of the errors are reset with a power cycle

## 4.8. Failures and troubleshooting

In case of failures or malfunctions, on Table 1 you can find the most common failures and the means of appropriate search:

**Table 1.** Troubleshooting

Failure	Possible cause	Troubleshooting
The sensor doesn't react to pressure	Pressure channel occlusion • Output stage failure	1 - Sensor power-off and disassembly 2 - Double check possible pressure channel occlusion and clean it from residuals or material
The transducer doesn't switch to Operational state (stays in Pre-operational)	• Broken primary element • Input stage error • Detected pressure value over range or under range	0 - Read error register and Manufacturer Status Register to identify the source of failure 1 - Sensor power-off and disassembly 2 - If the problem persists, send the sensor to factory for repair
	• Cut cable / broken connector • Device not connected • Broken supply • Overvoltage • Undervoltage • Floating power supply • Program sequence error • Logic/Process section error • Overtemperature on electronics • Output stage error	0 - Read error register and Manufacturer Status Register to identify the source of failure 1 - Sensor power-off and disassembly 2 - Check the correct connection of power supply 3 - Check the electrical continuity between the female plug and the power supply 4 - Check if the power supply level is within specifications 5 - Check voltage supply stability 6 - Check possible housing overtemperatures Remove the reasons, wait till cooling down and switch on the sensor 7 - If the problem persists, send the sensor to factory for repair 8 - If the sensor works fine, mount the sensor in the seat following instruction manual

## 4.9. Safe Parameterization

Due to CANopen communication functionality, user is allowed to configure and change the value of specific parameters which can affect the safety function.

For this reason, modification of these parameters need to be executed by an external tool and controlled by authorized personnel.

Moreover the procedure of modification, explained below, needs to follow specific rules included in safety standard EN 50325-5.

Two procedures, acting respectively on Communication and Application Parameters, are defined.

### 4.9.1. Safe Communication Parameterization

Safe Communication Parameterization involves objects included in SRDO (Safety Related Data Object)

The parameters and variables involved are modifiable via SDO and shown in the table below:

Index		Parameter Name
1301	1	SRDO1 Information direction
	2	SRDO1 Refresh time
	3	SRDO1 SRVT
	5	SRDO1 COB-ID1
	6	SRDO1 COB-ID2
1302	1	SRDO2 Information direction
	2	SRDO2 Refresh time
	3	SRDO2 SRVT
	5	SRDO2 COB-ID1
	6	SRDO2 COB-ID2

The configuration tool calculates the CRCs of the current parameter set for SRDO1 and SRDO2 (SRDOx signature), writes it to the device and finally writes the Safety Configuration valid flag (0xA5) to confirm the end of the configuration.

Here follows a reference to the parameters used to implement this procedure:

Index	Sub-index	Parameter Name
13FE	0	Configuration valid
13FF	1	SRDO1 signature
	2	SRDO2 signature

By default, the configuration valid is set to 0x00 (invalid).

After writing the configuration valid flag, the device independently calculates the CRC of the parameter set, and if it is equal to the CRC sent by the configuration tool, the configuration of the safe communication parameters is valid (0xA5). If the configuration is not valid an SDO abort code is returned. At this point, if also the safe application configuration is valid, the device can be sent to operational state, otherwise it remains in pre-operational state (safe state).

Once the configuration is validated, it can be saved in non-volatile memory, remaining valid until a new configuration change. The safe communication configuration must be done:

- At the first startup of the device (also from specifications, by default the configuration valid is set to 0x00)
- After the change of any of the safe communication parameters
- After a “Restore default parameters” command (0x1011 → ”load”)
- After the change of the Node-ID (it changes COB-IDs)

The change of safe communication parameters by SDO can be done only if the device is not in operational state, otherwise the SDO abort error is returned.

If the safe communication configuration is not valid, an EMCY message is sent. The type of error is also reported in the “Manufacturer Status Register” (0x1002).

#### 4.9.2. Safe Application Parameterization

The CANopen CiA 404 profile (DS 404-1, v2.1.0) does not define yet which application objects defined in the profile are to be considered “safety-related parameters”.

The KMC Safety defines by its own a set of application parameters that are involved in functional safety. The reason is that these parameters can change the numerical value of the Pressure Data (Safety Data) sent by SRDO.

Index/Sub-index	Parameter Name in CiA 404
6114, 1	AI ADC sample rate
6121, 1	AI input scaling 1 PV (Float)
6123, 1	AI input scaling 2 PV (Float)
6124, 1	AI input offset (Float)
6131, 1	AI physical unit PV
6132, 1	AI decimal digits PV
61A0, 1	AI filter type
61A1, 1	AI filter constant
9121, 1	AI input scaling 1 PV (Integer32)
9123, 1	AI input scaling 2 PV (Integer32)
9124, 1	AI input offset (Integer32)

The configuration of these safety-related application parameters is done similarly to configuration of the SRDO communication and mapping parameters.

The configuration tool calculates the CRC of the actual set of parameters (safety application configuration signature), writes it to the device and finally writes the safety application configuration valid flag (0xA5) to confirm the end of configuration. Two additional parameters are defined to configure the CRC for the safety application parameters and the safety application valid flag.

Index	Sub-Index	Parameter Name	Note
51FE	0	Safety application configuration valid	These parameters, defined as profile parameters for example in CiA 406 (61FE and 61FF), are not defined in CiA 404, so for the KMC are placed in manufacturer specific area.
51FF	1	Safety application configuration signature	

By default, the Safety application configuration valid is set to 0x00 (invalid).

After writing the safety application configuration valid flag the device calculates itself the CRC of the parameter set, and if it is equal the CRC sent by the configuration tool, the configuration of the safety application parameters is valid (0xA5). If the configuration is not valid an SDO abort code is returned. At this point, if also the SRDO configuration is valid, the device can be sent in operational state, otherwise it remains in pre-operational state (Safe State).

Once the configuration is validated, it can be saved in non-volatile memory, remaining valid until a new configuration change. The safe application configuration must be done:

- At the first startup of the device (by default the safety application configuration valid is set to 0x00)
- After the change of any of the safety application parameters
- After a "Restore default parameters" command (0x1011 → "load")

The change of safety application parameters by SDO can be done only if the device is not in operational state, otherwise the SDO abort error is returned.

Since the "autozero" command (0x6125 → "zero") changes the value of the "AI input offset" parameter, it can be done only if the device is not in operational state, otherwise the SDO abort error is returned.

If the safety application configuration is not valid, an EMCY message is sent. The type of error is also reported in the "Manufacturer Status Register" (0x1002).

If the safety application configuration is not valid, the device is in Safe State, and it can't go in operational state until the safety configuration application is validated.

The exact calculation sequence for the CRC is specified in detail in the user manual.

**NOTE:**

By default, CRC signature and Configuration Valid flags are set to 0, both for SRDO Communication and Safety-related application configuration. This means that the device will not go in Operational state until SRDO and Application configurations are done by the configuration tool. The configuration validity will be stored with the 0x1010 store command.

**NOTE:**

As reported at the beginning of paragraph, the CANopen CiA 404 profile (DS 404-1, v2.1.0) does not define a standard calculation of CRC for safe application parameters.

For this reason KMC CANopen Safety defines a method to disable, if required, the Safety-related application configuration mechanism by the object 0x51FD. This object is write protected by a signature given through the object 0x51FC as reported in the following table.

Index	Sub-Index	Parameter Name	Note
51FC	0	Safety application configuration check password	Writing the signature "sfty" in this object allows the modification of the object 51FD
51FD	0	Safety application configuration check enable	0: check disabled 1: check enabled (default)

If the object 0x51FD is reset to zero, no CRC calculation and activation will be required for the safety-related application parameters.

**IMPORTANT: For safety reasons it is not recommended to disable the check of the safety application configuration, and in any case it shall be executed and controlled by authorized personnel.**

NOTE: For further specification on CANopen Safety communication see also the Protocol User Manual.

**GEFRAN**

via Sebina, 74 - 25050 PROVAGLIO D'ISEO (BS) - ITALIA  
tel. 0309888.1 - fax. 0309839063 - Internet: <http://www.gefran.com>