

G3-T8

G-Mation G3 – 8 Temperature Inputs

USE AND INSTALLATION MANUAL

G3 T8 code F092709

code: 80653A - Ver 1.0 - 01-2025 - ENG



CONTENTS AND INDICES

1. PREFACE	4
1.1. Warnings and safety	4
1.2. Typographical conventions used in the manual.....	4
1.3. EtherCAT declaration	4
2. G-MATION G3 PLATFORM	5
2.1. System.....	5
2.2. Board modularity	6
2.3. Front polarisation.....	9
2.4. Mechanical dimensions	11
2.5. Front connector wiring	12
2.6. DIN rail mounting.....	13
2.6.1. G3-ECAT	13
2.6.2. G3-xxxx (all models unless otherwise specified).....	14
2.7. Positioning	17
3. TECHNICAL SPECIFICATIONS	18
3.1. Board equipment	18
3.2. Meaning of LEDs	19
3.3. Connections.....	20
3.3.1. Front connections.....	20
3.4. Resource software management.....	21
3.4.1. Module Objects	21
3.4.2. Gestione IOs	21
3.4.3. IOs configuration objects.....	22
3.4.4. Control objects	23
3.5. Alarms management.....	23
4. ACRONYM AND ORDER CODE	24
5. MARKING	25
6. DISPOSAL	26

1. PREFACE

1.1. Warnings and safety

Although all the information in this document has been carefully checked, Gefran S.p.A. cannot be held liable for the possible presence of errors, or for damage to persons or property due to improper use of this manual. Gefran S.p.A. also reserves the right to make changes to the content and form of this document and to the features of the devices it describes at any time without prior notice.

The devices described in this manual must be installed by qualified technicians, following current laws and regulations and in accordance with the instructions given in this manual. If the card is used in applications with risk of injury, or of damage to machinery or materials, it must be combined with auxiliary alarm devices. It is advisable to provide for the possibility of checking alarm activation also during normal operation.

Before interacting with the card, the operator must be adequately instructed in the system operation, emergency, diagnostics and maintenance procedures.

1.2. Typographical conventions used in the manual

Pay attention when the following symbols are found in the manual.



Indicates particularly important information relevant to correct product operation or safety, or provides instructions that must be strictly followed



Identifies an action that is possible / permitted



Highlights a risk condition for the installation technician or user due to hazardous voltage levels



Identifies an action that is NOT possible / NOT permitted

1.3. EtherCAT declaration

EtherCAT[®]

EtherCAT[®] is registered trademark and patented technology, licensed by Beckhoff Automation GmbH, Germany.

2. G-MATION G3 PLATFORM

2.1. System



G-Motion G3 is a modular IO system based on EtherCAT technology. EtherCAT provides a maximum of 65535 addressable modules.

A G3 rack of I/Os is composed of the system coupler, G3-ECAT, with a number of I/O boards on the right side as desired according to system needs and up to a maximum of 20.

The G3-ECAT module provides power supply for 20 boards.

If a number of boards greater than 20 is necessary, the power supply module G3-PWR must be inserted between the 20nd and 21st boards.

The boards are designed for coupling on a 35 mm DIN rail and the lateral coupling with the rack takes place by sliding to the left (refer to paragraph “2.6. DIN rail mounting” on page 13).

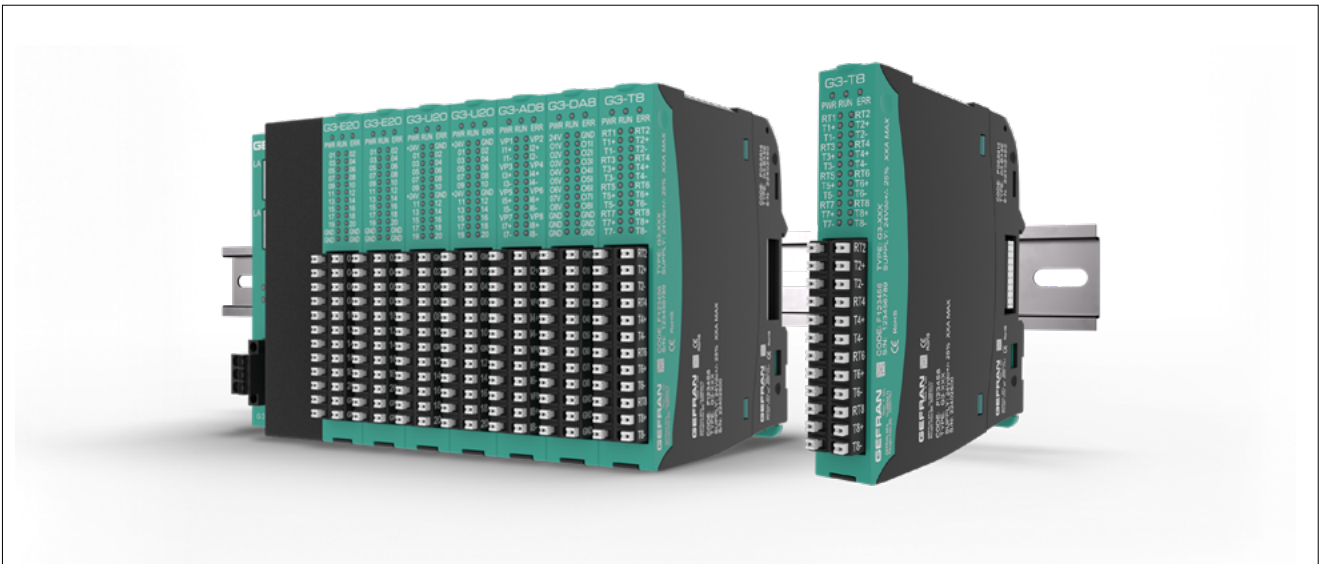

2.2. Board modularity

Each I/O board consists of three parts:

- **The base module:** it is the module that guarantees coupling with the din rail and bus transmission between one board and the next. It is called G3-BUS (F092614) and is common to all boards.
- **Electronics:** is the module that contains all the electronics dedicated to managing board I/Os. It is proprietary to each board.
- **The front:** it is the module that houses the push-in connector for the wiring and the front LEDs. It is proprietary to each board

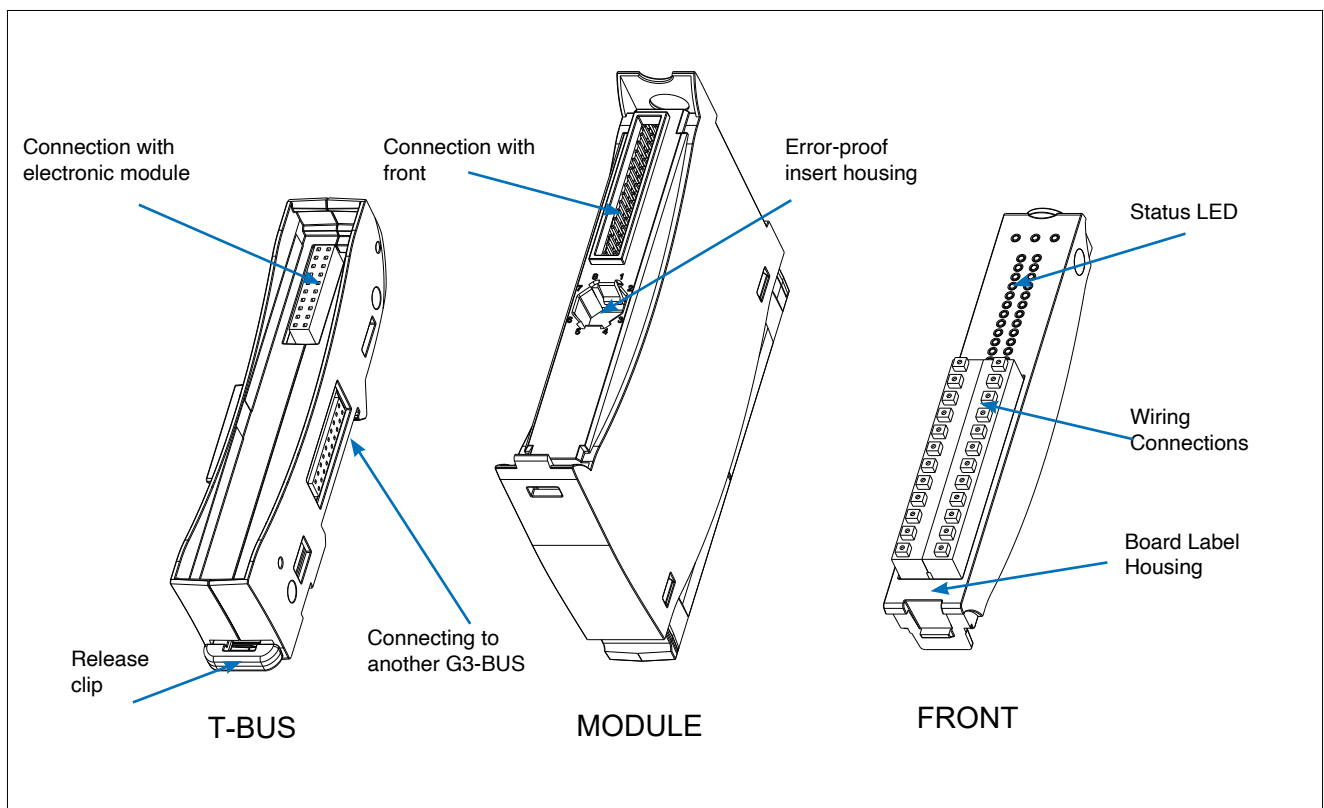
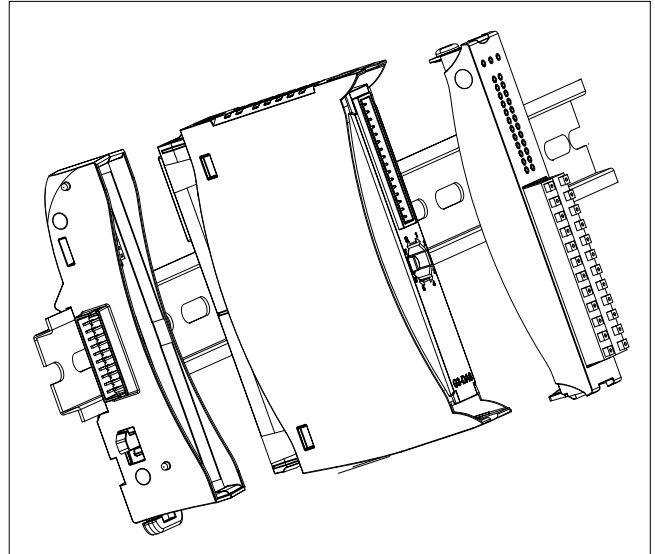

The coupling and uncoupling between the different parts is possible without the use of tools, using only your hands. The movement is constrained in such a way as to be easy and to prevent alignment errors that could compromise the connections.

Press the upper button as shown in the figure and pull the board down in the indicated direction to remove the front module.

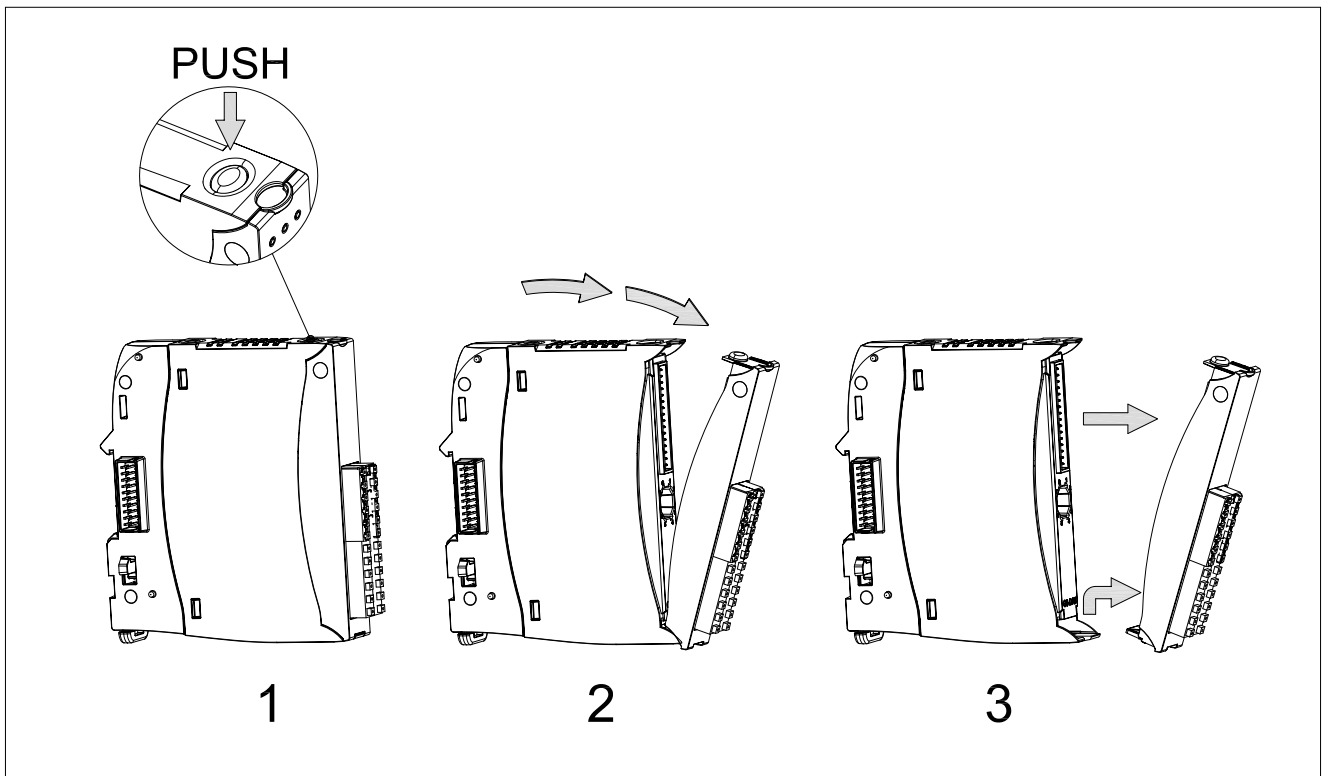

To re-couple the module, first place the lower part inside the constrained housing of the electronic part and then push the front until you feel the upper button couple.

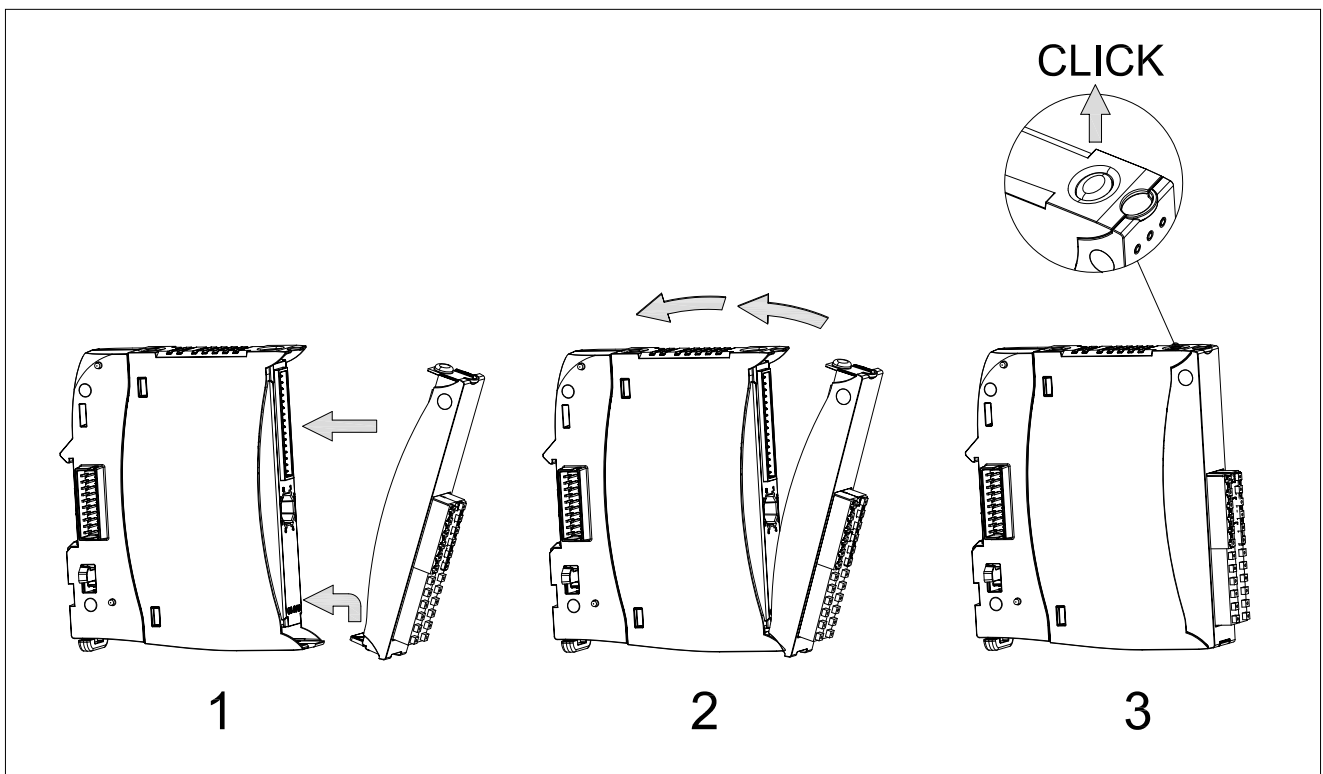

The electronic part can be detached from the base both with the front connected and without. To release the electronic part press the upper button as shown in the figure and pull the board down in the indicated direction.

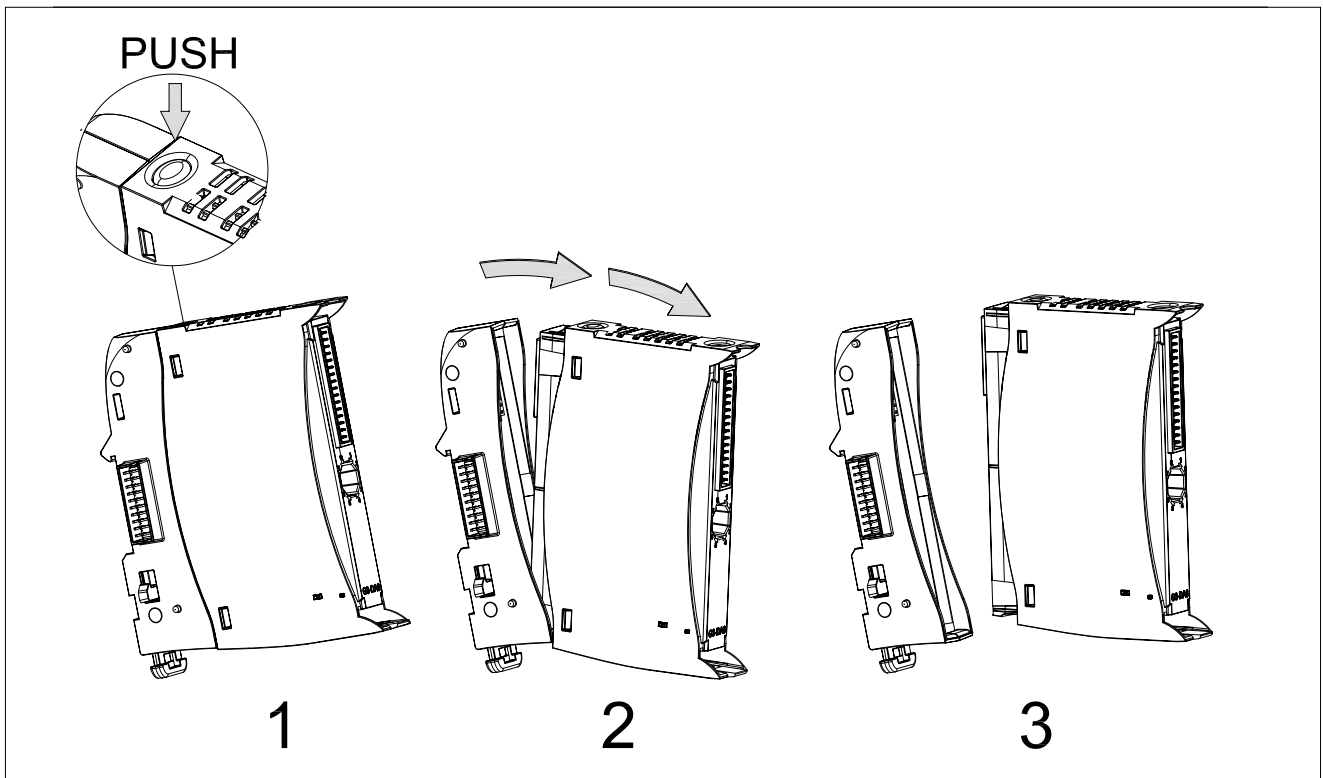

To re-couple the electronics, first place the bottom part inside the constrained housing of the base and then push the board until you feel the upper button couple.

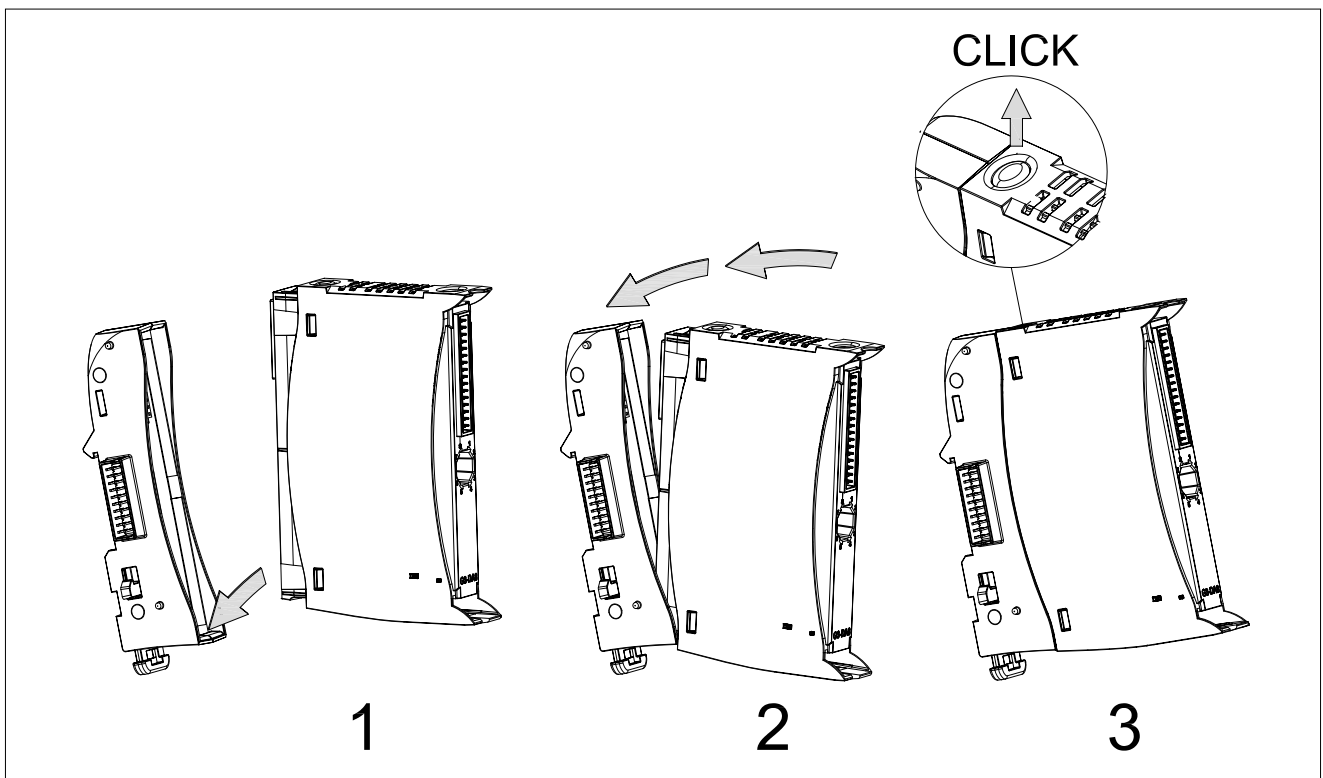

2.3. Front polarisation

A polarisation system is provided that allows you to associate a front to your board to avoid board and front positioning errors.

A kit of male-female coupled octagonal-shaped inserts may be provided as an accessory.

The figures on the insert are available in different versions so as to cover a wide range of combinations.

There is a housing for the male insert and one in the front for the female insert in the electronic part.

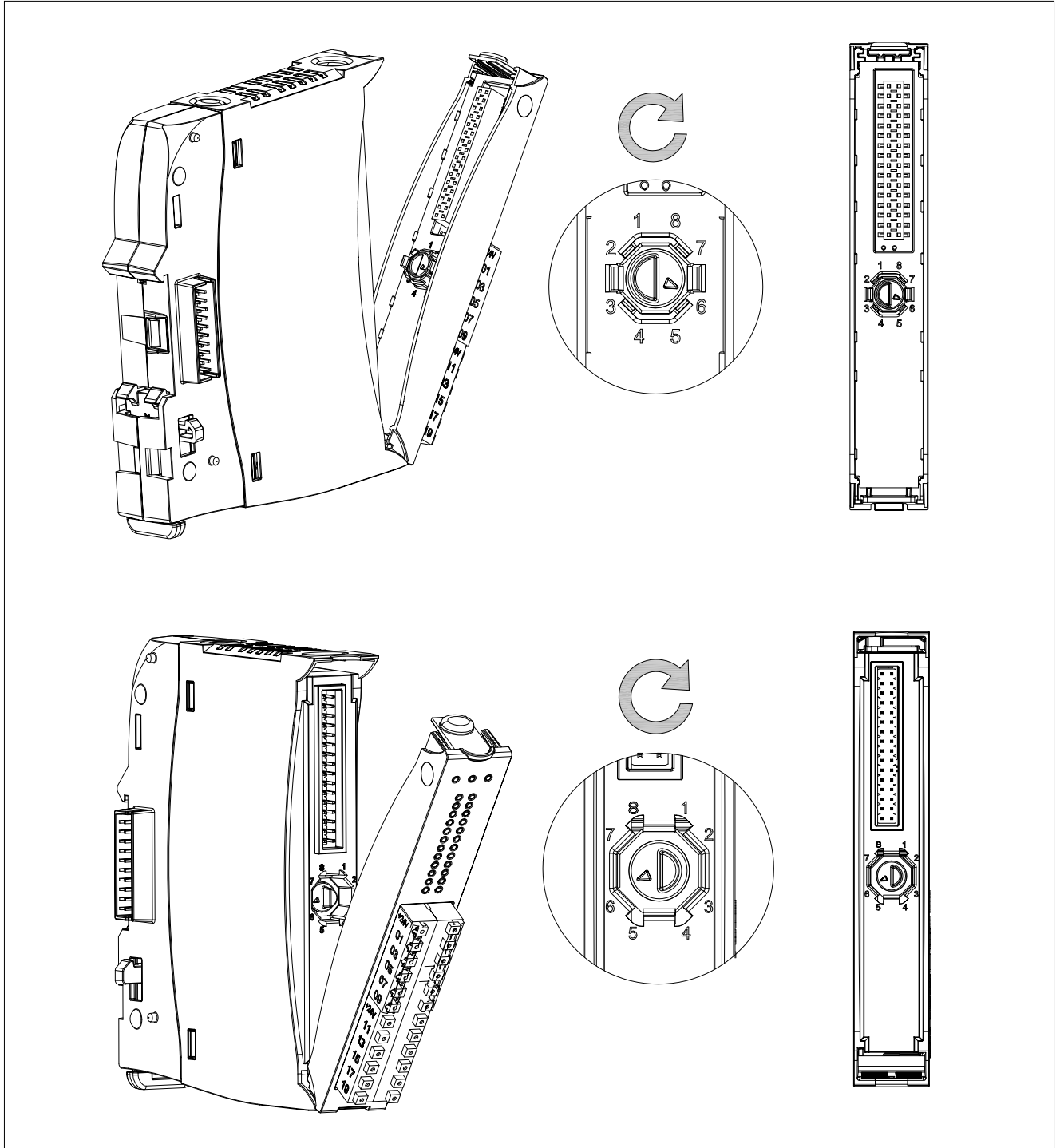

The insert must be mounted with the aid of tweezers and can be rotated in eight different positions. Proceed as shown in the figure by grasping the insert with tweezers to insert or remove the insert from the electronic board.

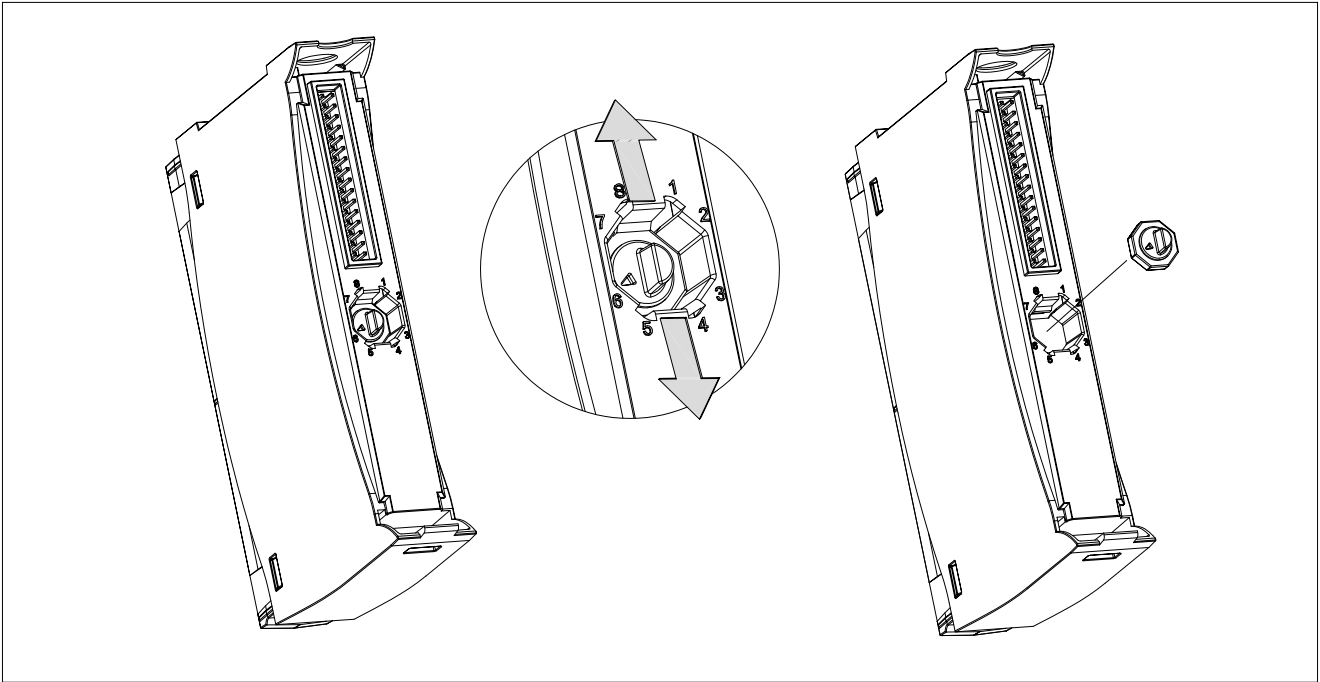

Proceed as shown in the figure by grasping the insert with tweezers to insert or remove the insert from the front module.

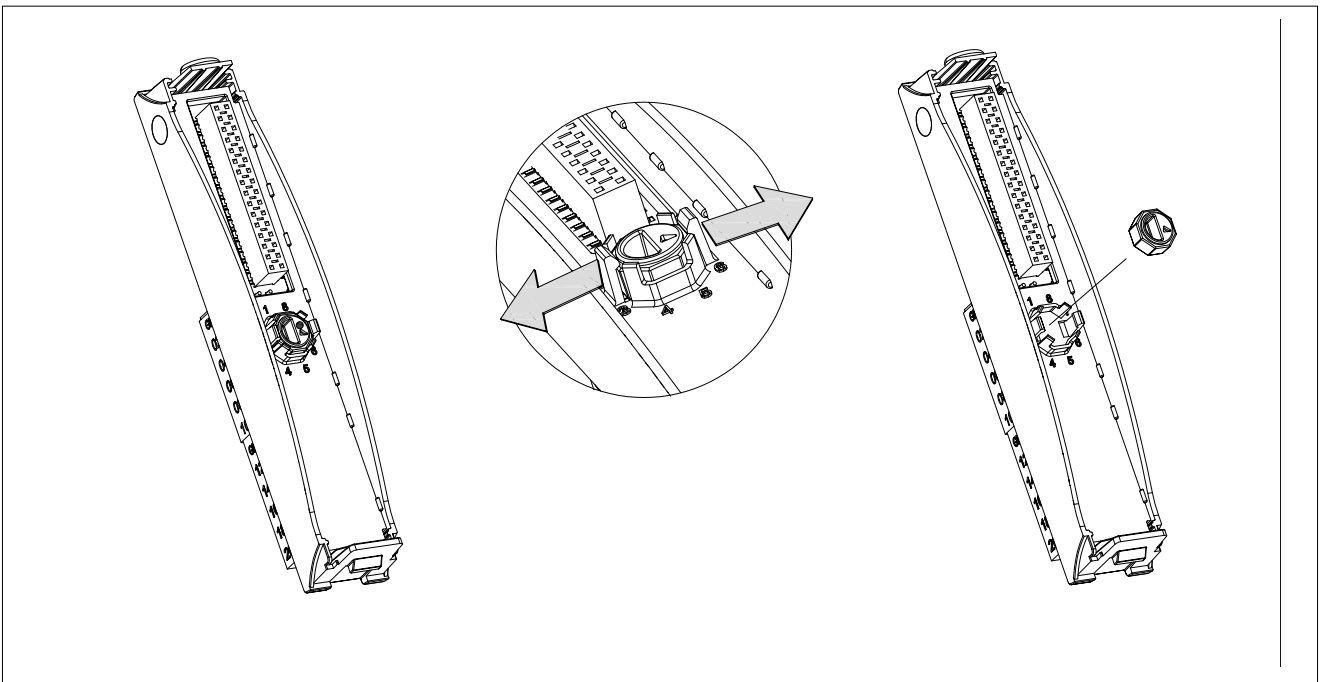

Once inserted, the inserts can be extracted and rotated as desired.

2.4. Mechanical dimensions

The mechanical dimensions of the product, without the DIN rail, may be seen in the image below.

Full G3-xxxx Board

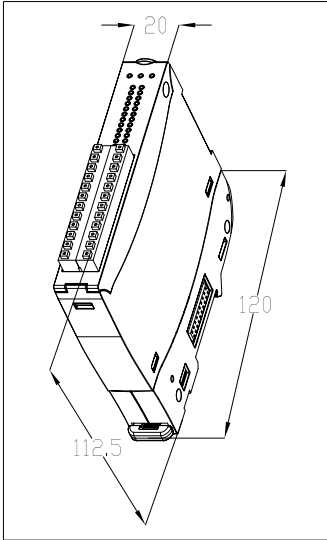

G3-ECAT hub head

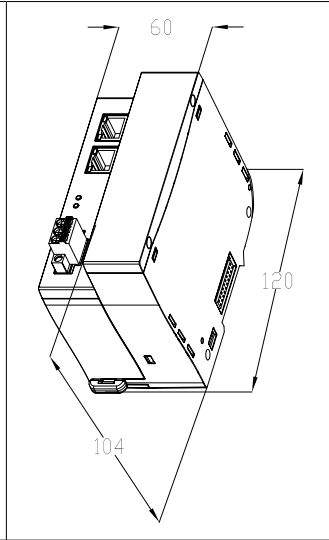

G3-JNC3

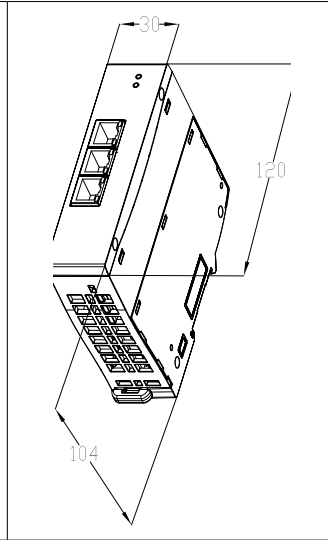

G3-JNC4

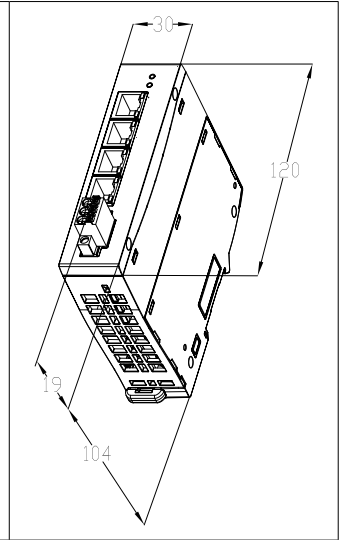

G3-BUS Base

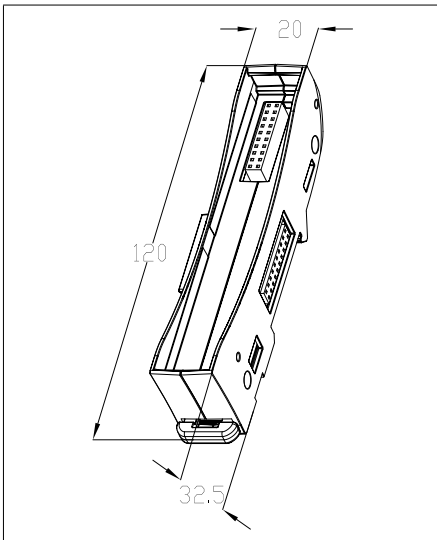

G3-xxxx E Electronic board

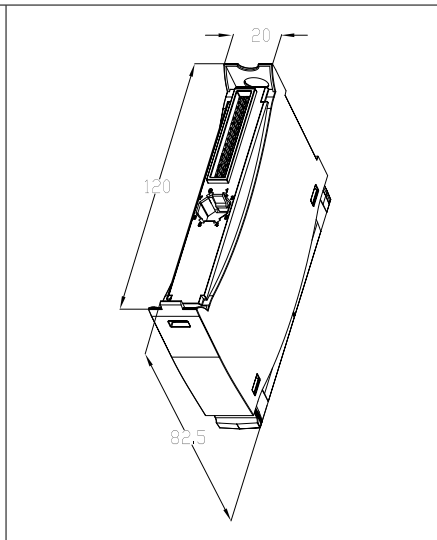

G3-xxxx F Front

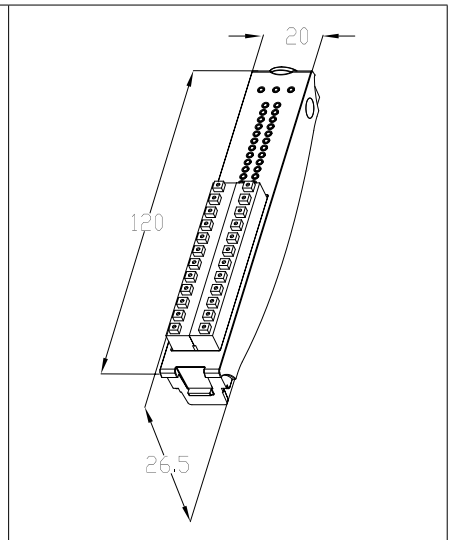

2.5. Front connector wiring

The connector can be wired both with the front coupled with the module and with the front detached from the module. The front connector can be placed on a bench to facilitate wiring.

For wiring, both the use of NON terminated flexible electrical wire and flexible electrical wire terminated with a TIP are allowed.

Use unipolar flexible electric wire with maximum section of 1.50 mm² (AWG 16) with 8 - 9 mm strip length. If a TIP is used, use a model with a section appropriate to the wire used and with a length of 8 - 9 mm.

To connect the wire **without TIP**:

press the button with a screwdriver insert the wire into the seat release the button.

To connect the wire **with TIP**:

push the tip directly into the seat

To disconnect the wire:

press the button with a screwdriver pull out the wire/tip
release the button

A pressed flexible wire can be used as an alternative to the TIP.



It is recommended NOT TO WELD the electric wire.

Minimum temperature rating of the cable to be connected to the field wiring terminals, 85 °C

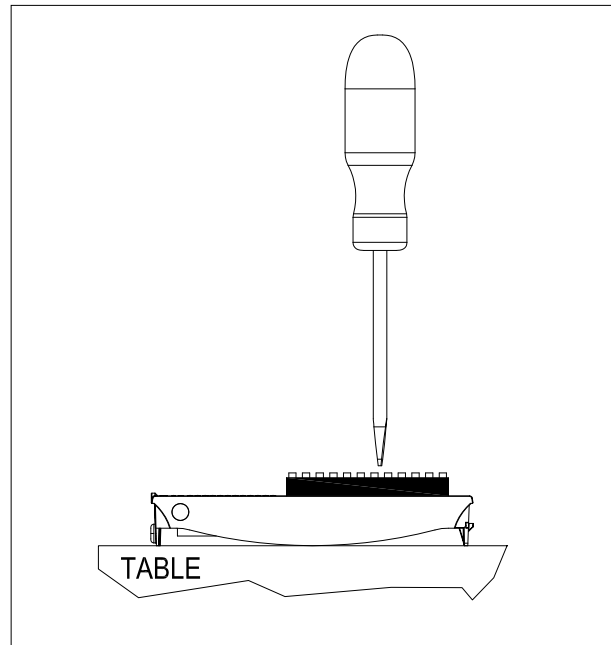

2.6. DIN rail mounting

2.6.1. G3-ECAT

To mount the G3-ECAT to the din bar, unclip the lower clip and leave it in the open stable position. Enter the top of the latch on the rail, rotate the board and place it on the DIN rail. Raise the lower clothespin slightly to free it and allow it to be hooked to the bar even in the lower part.

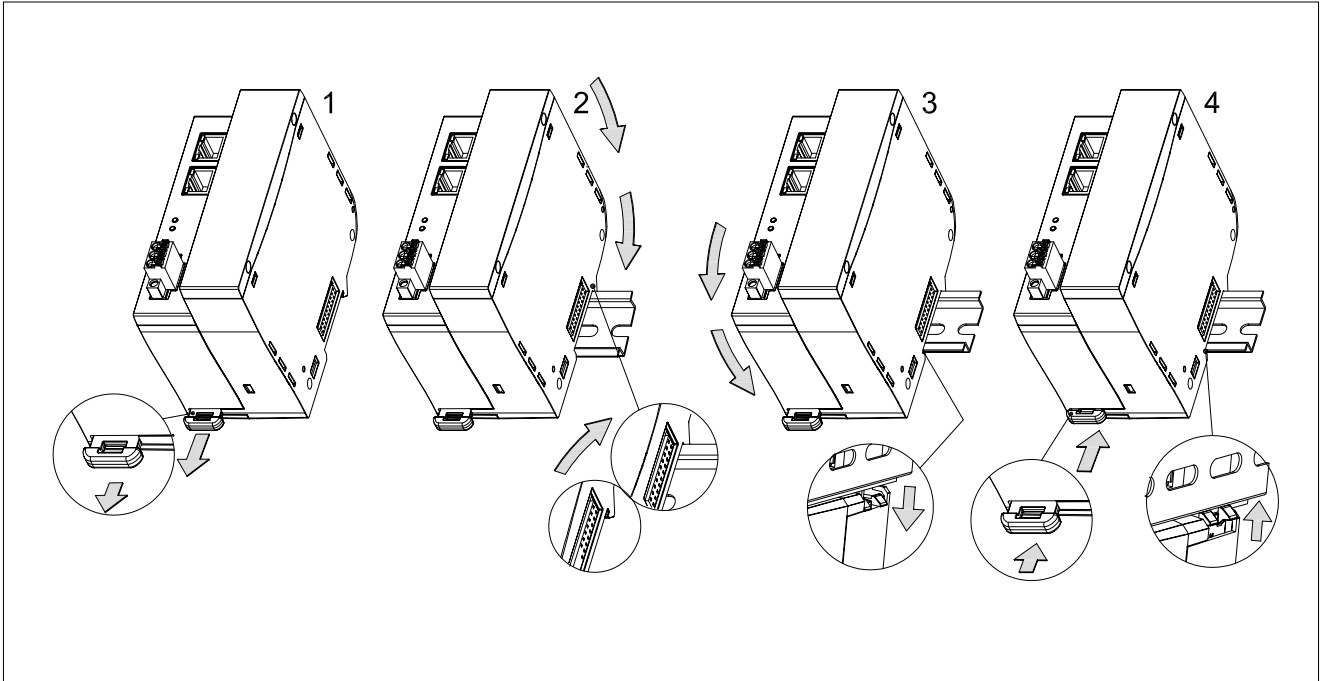

To remove the head the hub from the DIN rail, release the lower clip by slightly levering with a screwdriver and turn the board to release it.

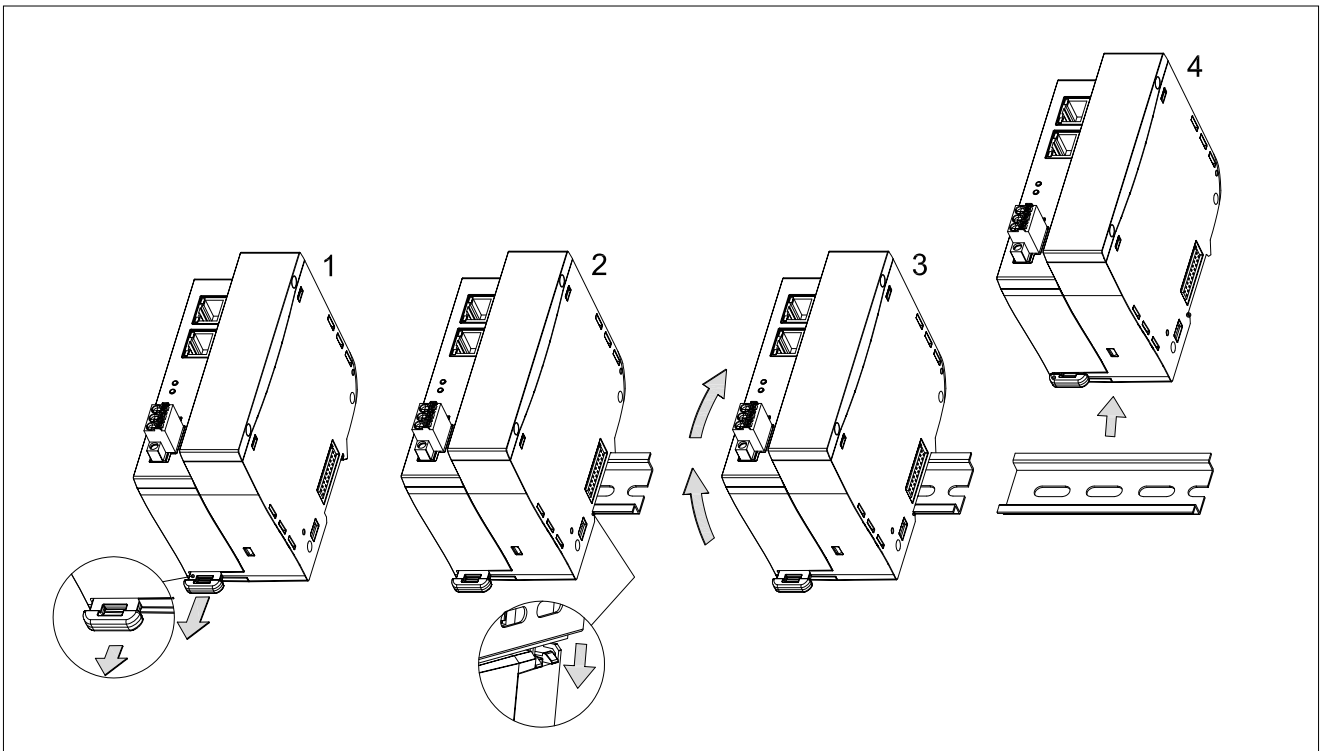

2.6.2. G3-xxxx (all models unless otherwise specified)

To mount the module to the din rail, unclip the lower clip and leave it in the open stable position. Insert the part top of the hook on the rail, rotate the board and place it on the DIN rail. Raise the lower clothespin slightly to free it and allow it to be hooked to the bar even in the lower part.

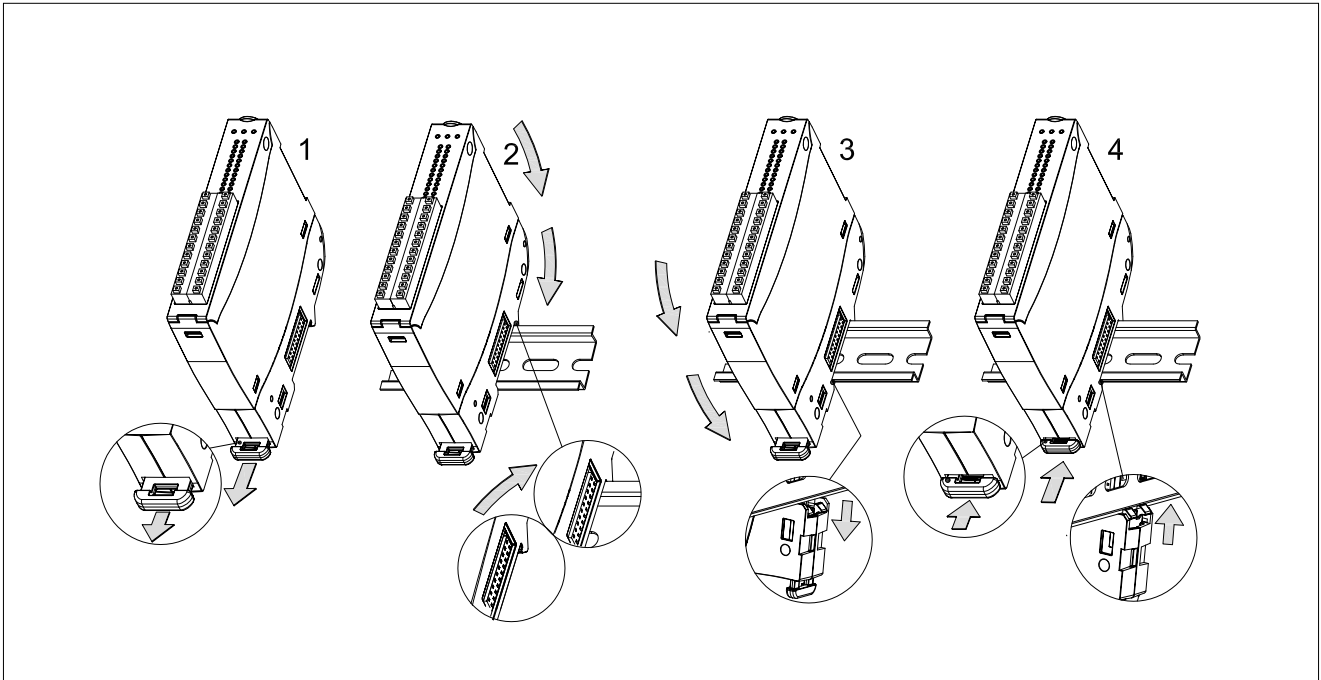

Remove the board from the DIN rail, release the lower clip using a screwdriver to lever it slightly, and turn the board to release it.

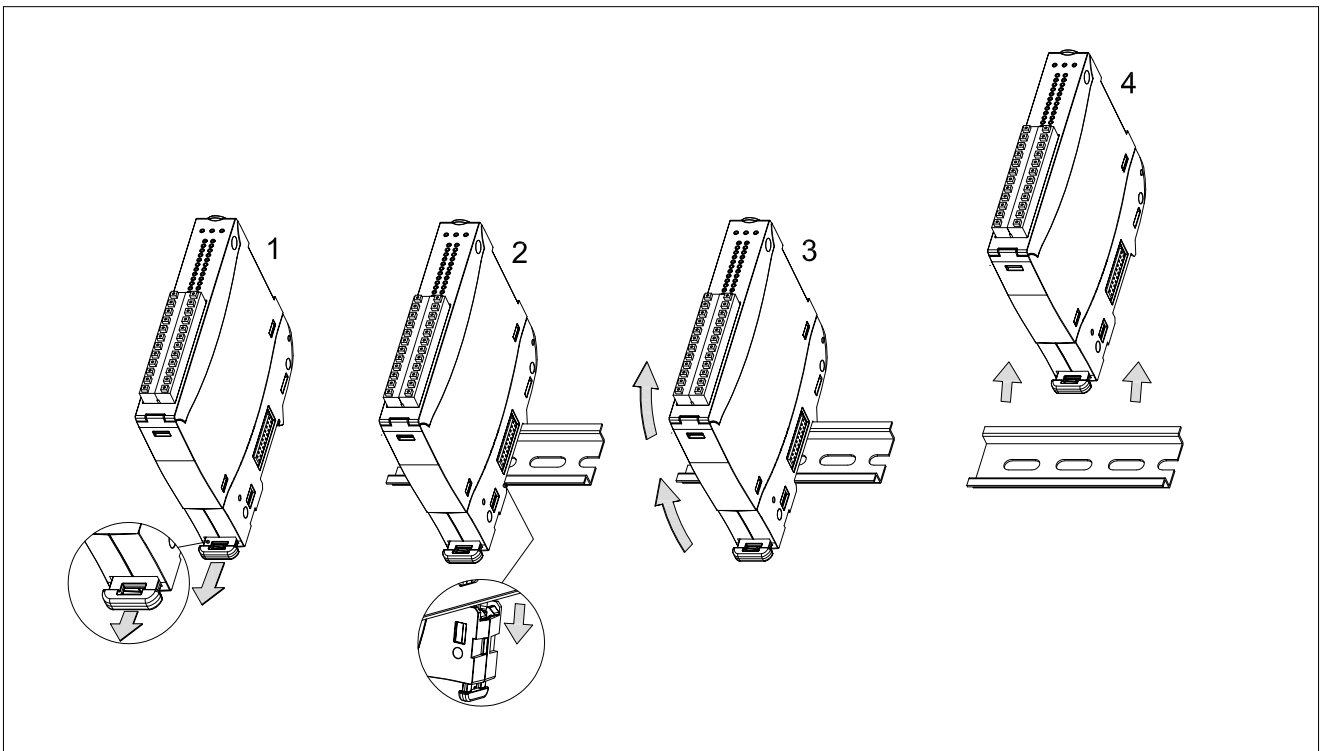

Once the board has been coupled, it is possible to secure the lower clip in the stable released position and slide it longitudinally on the rail until it is coupled to the previous board.

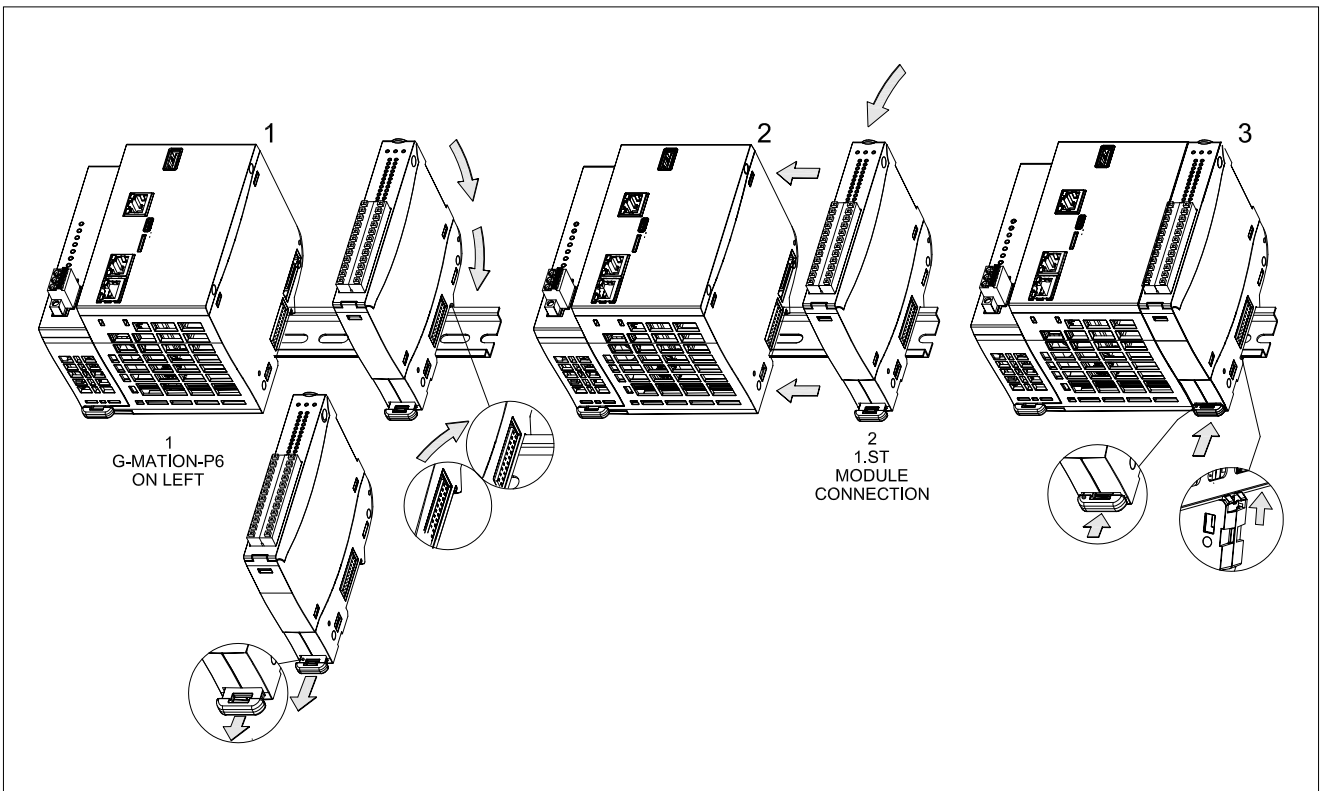
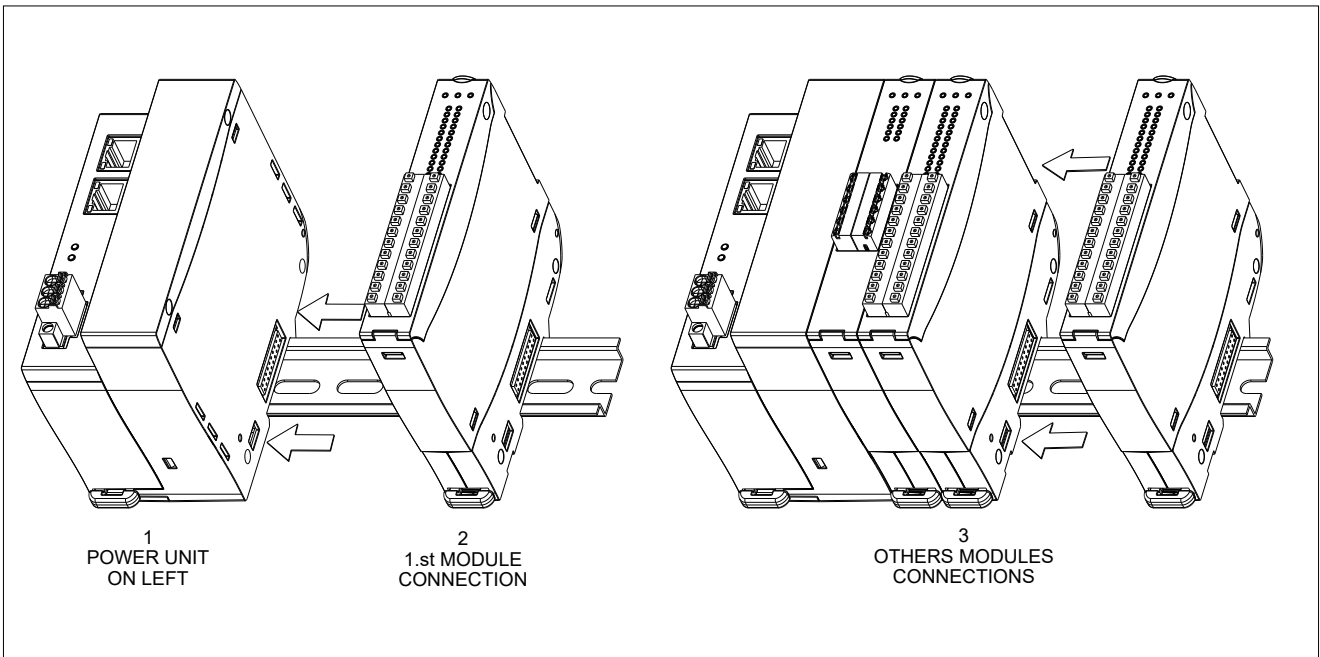

Once coupled, reinsert the lower clip so that the coupling with the DIN rail and the left board is firm and maintained by the force of the internal spring.

To release the board from the rack, use the lower clip and lock it in the stable released position. Slide the board to the right to separate it from the rack. Use the lower clip again and pull it so that you can lift the board from the din r.

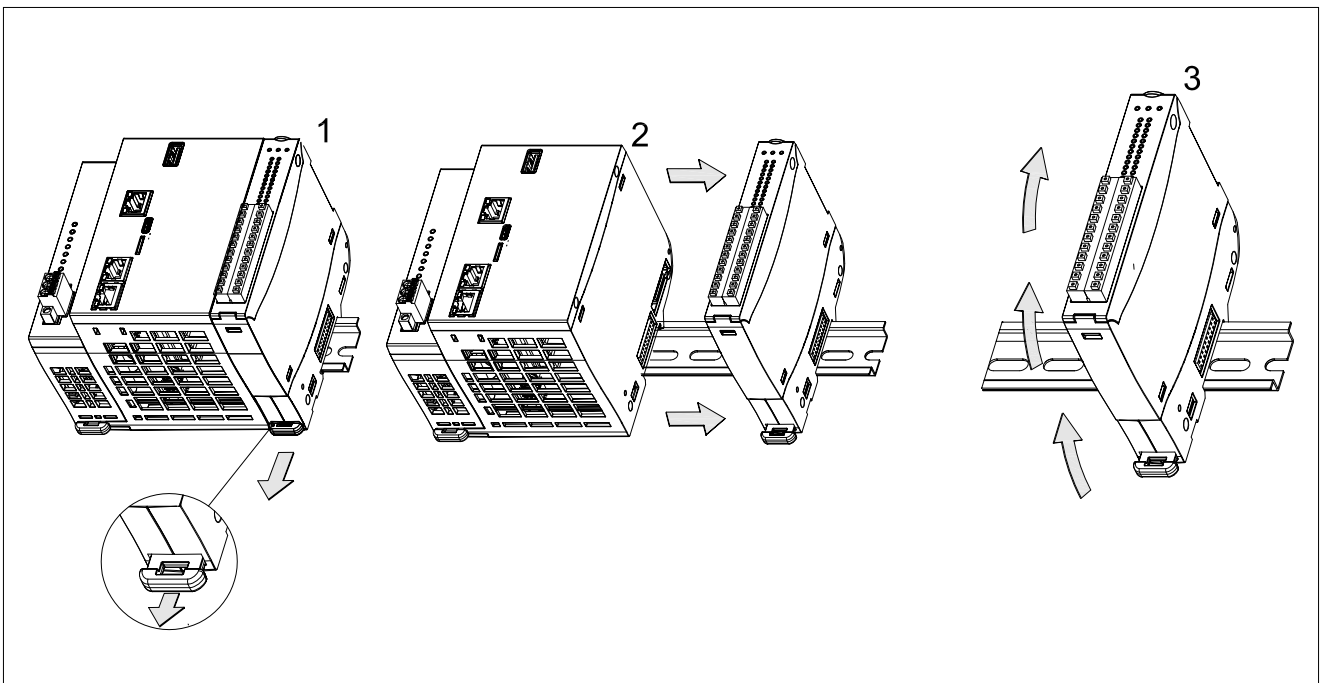
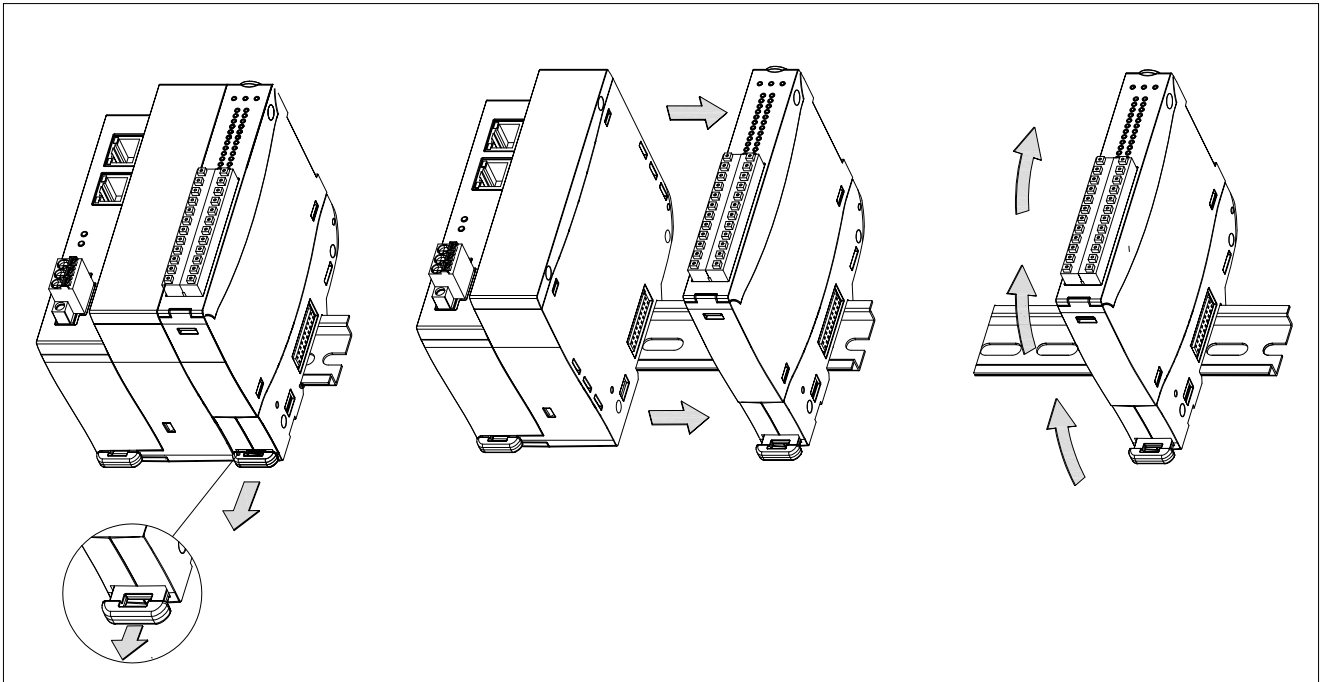

2.7. Positioning

For the installation into an electrical cabinet of a G3 I/O rack, the ventilation distances as defined in the figure must be respected underlying.

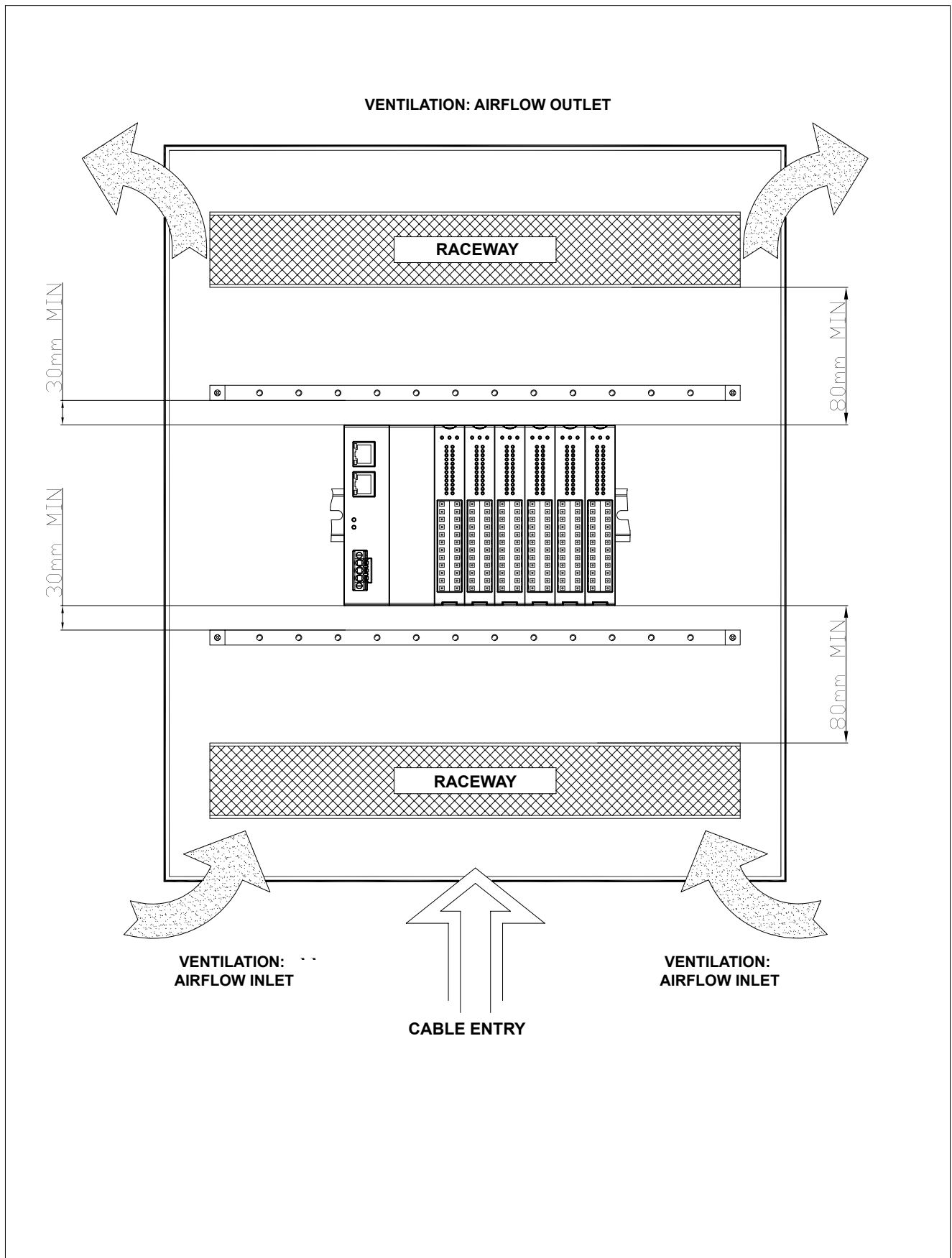

3. TECHNICAL SPECIFICATIONS

3.1. Board equipment

The G3-10 is a temperature acquisition module which can manage up to 8 thermocouples or RTD temperature sensors.

The inputs are software configurable as type J, K, N, R, S, E, L, T, C, B thermocouple and RTD inputs.

Internal voltage-to-temperature linearization and cold junction compensation is based on standard ITS90 polinomials for the best accuracy. G3-ET8 can be connected with all the G-Mation gateways and Px CPU modules from which it receives power supply.

Acquisition time is less than 200 ms for the 8 channels. Temperatures are supplied in tenths of a degree Celsius (°C) or Fahrenheit (°F).



TECHNICAL DATA	
8 optically isolated temperature inputs	24 bit A/D conversion 20 Hz pass band input impedance > 10MΩ sample time for 8 channels :200ms max. Input isolation up to 1,5 kV
Type of configurable input	Thermocouples: TC J, (-210.0...1200.0°C/-346.0...2192.0°F) TC K, (-270.0...1300.0°C/-454.0...2502.0°F) TC N, (-270.0...1300.0°C/-454.0...2372.0°F) TC R, (-50.0...1768.0°C/-58.0...3214.0°F) TC S, (-50.0...1768.0°C/-58.0...3214.0°F) TC E, (-270.0...1000.0°C/-454.0...1832.0°F) TC L, (-200.0...900.0°C/-328.0...1652.0°F) TC T, (-270.0...400.0°C/-454.0...752.0°F) TC U, (-200.0...600.0°C/-328.0...1112.0°F) TC C, (0.0...2315.0°C/32.0...4199.0°F) TC B, (40.0...1820.0°C/104.0...3308.0°F) RTDs (2 and 3 wires connection): Pt100 (-200.0...850.0°C/-328.0...1562.0°F) Pt1000 (-200.0...850.0°C/-328.0...1562.0°F)
Accuracy	Thermocouple accuracy: reading error of less than 0.1% at full scale Cold junction accuracy <1°C to 25°C Cold junction compensation: rejection greater than 40:1 as the room temperature RTD Input Accuracy: Calibration error < 0.1% referring to full scale Linearization error < 0.06°C Thermal drift <0.002% referred to full scale / °C of temperature change ambient ambient temperature of 25°C
Unit measure	Temperatures in tenths of °C/°F
Power supply	From G3-ECAT or Px CPU modules
Overvoltage Category	II
Power dissipation	1,2 W, 5%
MECHANICAL DATA	
Dimensions	120x110x20 mm
Weight	150 g
Protection level	IP20 For UL: not UL evaluated. Open type device
Connector	Front 24 pin-5.08mm pitch removable con-nection system with spring wire retention, no tool required to fix or remove wires
Attachment	Mechanically snaps onto DIN rail
ENVIRONMENTAL CONDITIONS	
Working temperature	-10...55°C
Storage temperature	-25...70°C
Humidity	max. 90% Rh not condensing
Pollution degree	2
Maximum altitude	2000 m

3.2. Meaning of LEDs

	ACRONYM	COLOR	LED STATUS	MEANING
MODULE DIAGNOSTIC 	PWR	YELLOW	OFF	no power supply
			ON	power supply present
	RUN	GREEN	OFF	INIT or BOOT status
			Blinking: 2.5 Hz (Slow blinking)	PRE-OPERATIONAL status
			Single Flash: on 200 ms off 1000 ms (Single Flash)	SAFEOP status
			Flickering: 10 Hz (Fast flickering)	BOOT status
			ON	OPERATIONAL status
	ERR	RED	OFF	no error
			Blinking (Slow blinking)	configuration error
			Single Flash:	generic runtime error
			Double Flash	wdog on cyclic data
			Flickering (Fast flickering)	error during the BOOTING phase

If communication with the master is active, more information can be obtained from the objects in the module itself.

3.3. Connections

3.3.1. Front connections

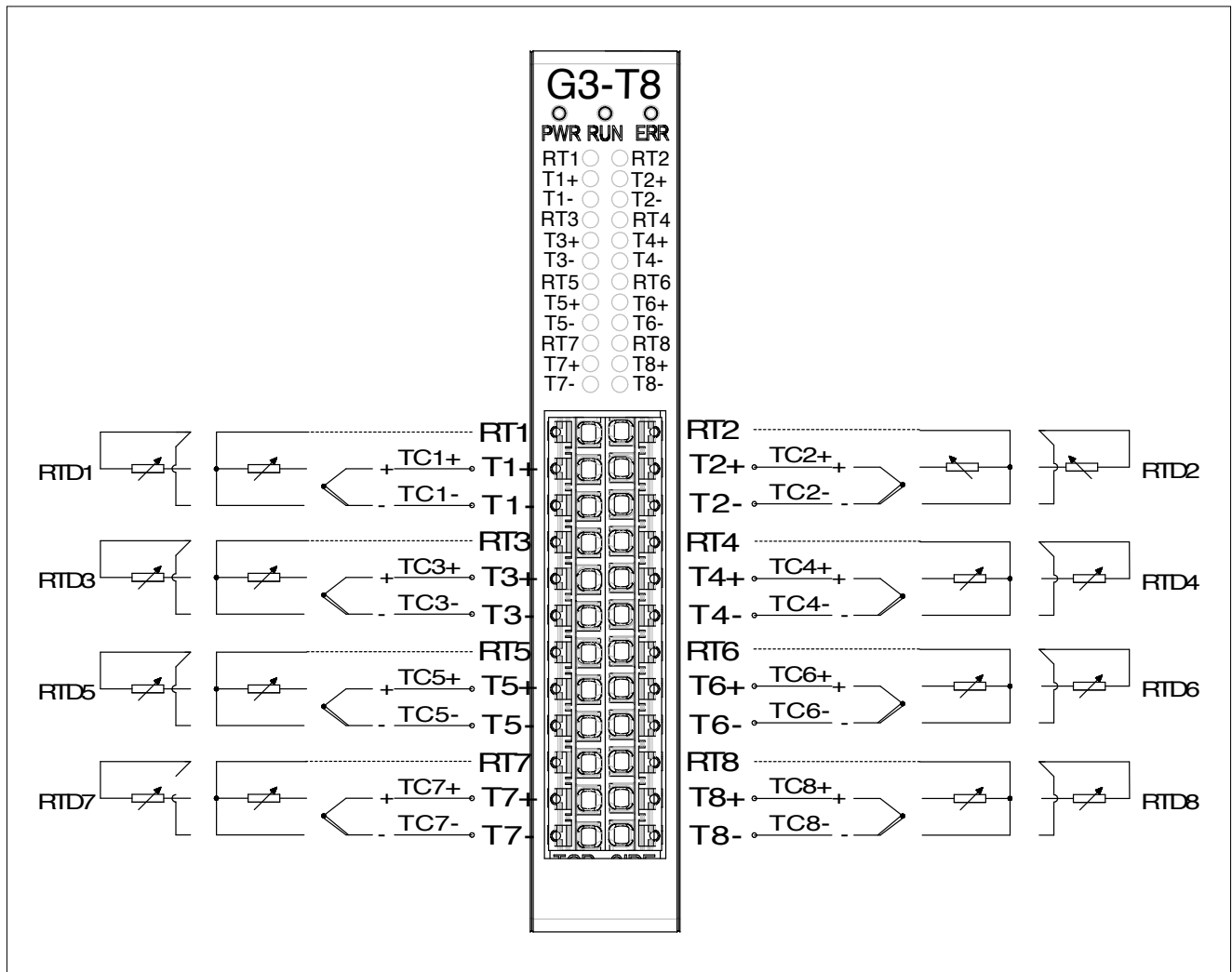

For RTD (heat resistors) inputs, use shielded flexible multi-pole electric wire with 0.5 .. 1.0 mm² section and 8 .. 9 mm strip length.

For THERMOCOUPLE inputs use COMPENSATED wires consistent with the type of thermocouple used so as not to alter the measurement. The allowed wire sections are 0.5 .. 1.0 mm² with 8 .. 9 mm strip length. It is advisable not to use TIPS so as not to introduce errors in sensor readings.

Normally, shielded thermocouples and heat resistors have the shield connected to the sensor bulb that automatically connects to GROUND once installed in the equipment.

If this is not the case, connect the sensors to GROUND near the temperature measurement point.

3.4. Resource software management

G3-T8 module resources are available through the objects described below, which are provided by the EtherCAT protocol according to directive ETG 5001.

All objects are made available to the master through the ESI file called:
Gefran G3-T8 Vxx where xx is the version.

The file is available on the Gefran WEBSITE (www.gefran.com).

3.4.1. Module Objects

INDEX	SUB.	STORE	NAME	MAP	TYPE	ACCESS	DEFAULT / NOTE
0x1000	0	No	Device type	No	UDINT	RO	0x0001389 5001 TBD
0x1001	0	No	Error Register	No	USINT	RO	0x00
0x1008	0	No	Device Name	No	STRING	RO	G3-T8
0x1009	0	No	Manufacturer Hardware version	No	STRING	RO	03
0x100A	0	No	Manufacturer Software version	No	STRING	RO	1.3
0x1018	0	No	Objects number	No	USINT	RO	4
	1	No	Vendor Id	No	UDINT	RO	0x0000 0093 (Gefran)
	2	No	Product Code	No	UDINT	RO	0x00000BBE (3006)
	3	No	Revision Number	No	UDINT	RO	0x0000 0003
	4	No	Serial Number	No	UDINT	RW	32-bit product serial number

3.4.2. Gestione IOs

INDEX	SUB INDEX	NAME	TYPE	ACCESS	DEFAULT / NOTE
0x6002	0	Objects number	USINT	RO	8
	1	Temperature Input 1	DINT	RO	
	2	Temperature Input 2	DINT	RO	
	3	Temperature Input 3	DINT	RO	
	4	Temperature Input 4	DINT	RO	
	5	Temperature Input 5	DINT	RO	
	6	Temperature Input 6	DINT	RO	
	7	Temperature Input 7	DINT	RO	
	8	Temperature Input 8	DINT	RO	

The value of the temperature input 1..8 is available in the object in sub-indexes 1..8
 Input Temperature Type (n): **DINT**

3.4.3. IOs configuration objects

Temperature Type objects

INDEX	SUB INDEX	NAME	TYPE	ACCESS	DEFAULT / NOTE
0x8000	0	Objects number	USINT	RO	8
	1	Temperature Type 1	ENUM	RW	0
	2	Temperature Type 2	ENUM	RW	0
	3	Temperature Type 3	ENUM	RW	0
	4	Temperature Type 4	ENUM	RW	0
	5	Temperature Type 5	ENUM	RW	0
	6	Temperature Type 6	ENUM	RW	0
	7	Temperature Type 7	ENUM	RW	0
	8	Temperature Type 8	ENUM	RW	0

The configuration of temperature inputs 1..8 is available in sub-indexes 1..8.

Type Temperature Type (n):

- 00 = 0..60mV
- 01 = J, -210.0..1200.0°C/-346.0..2192.0°F)
- 02 = K, -270.0..1372.0°C/-454.0..2501.6°F
- 03 = R, -50.0..1768.0°C/-58.0..3214.4°F
- 04 = S, -50.0..1768.0°C/-58.0..3214.4°F
- 05 = T, -270.0..400.0°C/-454.0..752.0°F
- 06 = N, -270.0..1300.0°C/-454.0..2372.0°F
- 07 = E, -270.0..1000.0°C/-454.0..1832.0°F
- 08 = C, 0..2300.0°C/32..4172.0°F
- 09 = D, 0..2300.0°C/32..4172.0°F
- 10 = B, 44.0..1800.0°C/104.0..3308.0°F
- 11 = L, -200.0..900.0°C/-328.0..1652.0°F
- 12 = Pt100 2&3 fili, -200.0..850.0°C/-328.0..1562.0°F
- 13 = Pt1000 2&3 fili, -200.0..850.0°C/-328.0..1562.0°F

Software Filter

INDEX	SUB INDEX	NAME	TYPE	ACCESS	DEFAULT / NOTE
0x8001	0	Objects number	USINT	RO	8
	1	Software Filter Value 1	ENUM	RW	0
	2	Software Filter Value 2	ENUM	RW	0
	3	Software Filter Value 3	ENUM	RW	0
	4	Software Filter Value 4	ENUM	RW	0
	5	Software Filter Value 5	ENUM	RW	0
	6	Software Filter Value 6	ENUM	RW	0
	7	Software Filter Value 7	ENUM	RW	0
	8	Software Filter Value 8	ENUM	RW	0

The inlet filter type selector .. 8 is available in sub-indexes 1..8.

Type Temperature Filter (n):

- 00 = 1Hz
- 01 = 0,5 Hz
- 02 = 0,1 Hz
- 03 = 0,05 Hz
- 04 = 0,01 Hz
- 05 = 0,005 Hz
- 06 = 0,001 Hz

Degree Selection

INDEX	SUB INDEX	NAME	TYPE	ACCESS	Default / Note
0x8002	0	Degree Selection	USINT	RW	0x00

The unit selector setting defines the measurement value in °C or °F.

Degree Selector Type: **USINT**

00 = °C, Celsius degrees

01 = °F, Farenheit degrees

3.4.4. Control objects

INDEX	SUB.	STORE	NAME	MAP	TYPE	ACCESS	DEFAULT / NOTE
0x9000	0	No	Device Code	No	UINT	RO	0x0BBE
0x9001	0	No	Hardware Revision	No	USINT	RW	0x03
0x9002	0	No	Firmware Version	No	UINT	RO	0x0130
0x9003	0	No	Serial Number	No	UDINT	RW	0x00000000
0x9004	0	No	Order Code	No	STRING(7)	RW	F092609

3.5. Alarms management

INDEX	SUB.	STORE	NAME	MAP	TYPE	ACCESS	DEFAULT / NOTE
0xA000	0	No	Objects number	No	USINT	RO	8
	1	No	Alarm Status Channel 1	No	USINT	RO	0x00
	2	No	Alarm Status Channel 2	No	USINT	RO	0x00
	3	No	Alarm Status Channel 3	No	USINT	RO	0x00
	4	No	Alarm Status Channel 4	No	USINT	RO	0x00
	5	No	Alarm Status Channel 5	No	USINT	RO	0x00
	6	No	Alarm Status Channel 6	No	USINT	RO	0x00
	7	No	Alarm Status Channel 7	No	USINT	RO	0x00
	8	No	Alarm Status Channel 8	No	USINT	RO	0x00

The alarm status of inputs 1..8 is available in the object at sub index 1..8

Alarm Status Type (n): **USINT**

0 = no alarm

1 = lower full scale: the input is below the minimum value

2 = upper full scale: the input is above the maximum value

4 = Unable to read a coherent value, generic reading error (sensor/system)

8 = system out of scale, sensor not connected or faulty

4. ACRONYM AND ORDER CODE

COMPLETE MODULE	G3-T8	F092709
Front	G3-T8 F	F092623
Electronic module	G3-T8 E	F092609
Bus	G3-BUS	F092614

5. MARKING

Every module contain the datas of every module part and the full module.

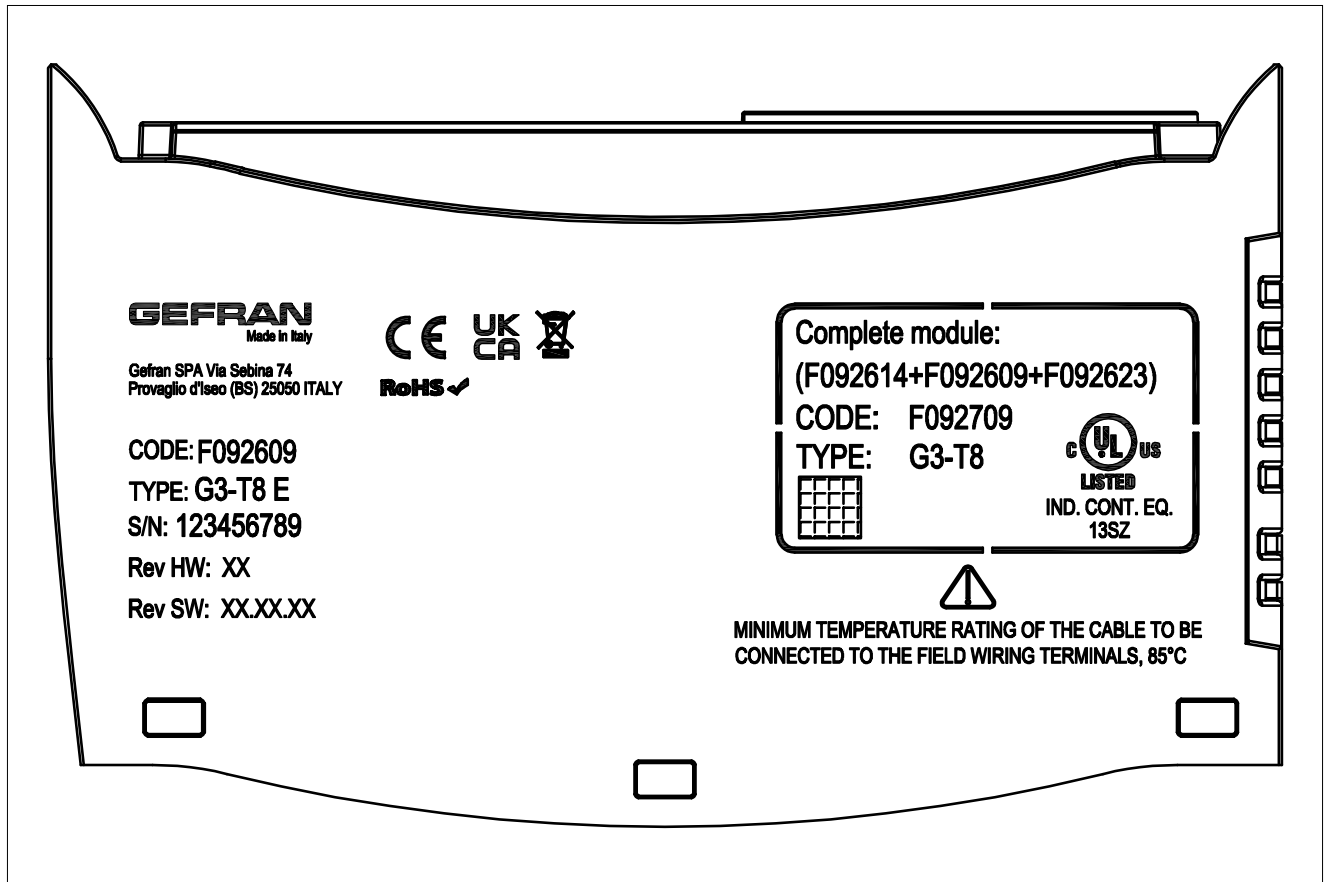

The following information may be found on the label:

- CODE: product code
- S/N: product serial number
- TYPE: product name / description
- HW: hardware version 1 .. 99
- SW: software version 1.0.0 .. 99.99.99
- GEFRAN logo
- certifications
- logo specifying product disposal

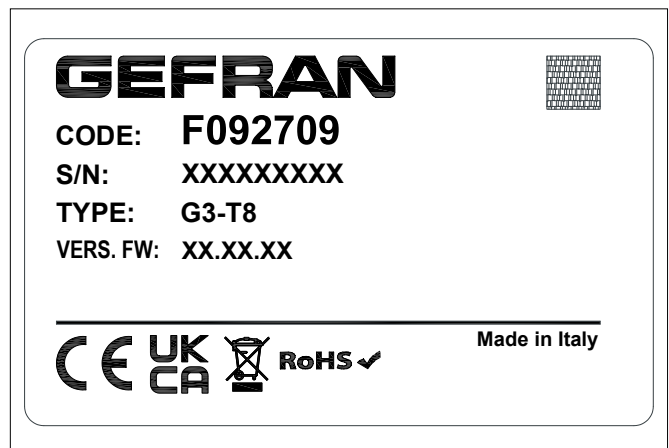

This symbol present on the product label stands for further indications on product manual. For correct and sale installation, follow the instructions and observe the warnings contained in this manual. No hazards shall arise by any reasonably foreseeable misuse in a way not intended, and not described in this manual. The complete manual is available for download from the website www.gefran.com. UL file number E-198546.

Certifications

	This device conforms to European Union Directive 2014/30/EU and 2014/35/EU as amended with reference to generic standards: EN 61000-6-2 (immunity in industrial environment) EN 61000-6-4 (emission in industrial environment) - EN 61010-1 (safety regulations).
	cULus listed, Conformity UL61010-1 - File: E198546

6. DISPOSAL



The product must be disposed of in accordance with the regulations in force.

Some of the components used in the devices can cause damage to the environment if incorrectly disposed.

By collecting the disused equipment separately, it can be recycled, treated or disposed of in an environmentally friendly manner, thus helping to prevent the environment and public health from being affected negatively and enabling reuse and/or recycling of the materials forming the equipment.

Pursuant to art. 26 of Legislative Decree 14 March 2014, no. 49 "Implementation of Directive 2012/19/EU on waste from electrical and electronic equipment (WEEE)".

The symbol showing a crossed-out wheeled bin on equipment or its packaging indicates that the product must be collected separately from other waste at the end of its useful life.

GEFRAN