



OPERATING INSTRUCTIONS MANUAL

codice: **80586A_02-2022 - ENG**

ATTENTION!

This manual must always be available to operators of the devices described here.

Always make sure that you have the latest version of the manual, which is available for free download from the GEF-RAN website (www.gefran.com).

Installers and/or maintenance personnel are required to read this manual and to precisely follow the instructions contained in it and in its attachments.

GEFRAN will not be liable for any damage to persons and/or property, or to the product itself, caused by failure to follow the instructions and observe the warnings given below.



This manual and its attachments may be freely reproduced as long as they are not changed in any way and every copy contains this warning and the declaration of ownership by Gefran S.p.A.

REVISION DOCUMENTS

DATE	CODE	UPDATE	N. pages of the document

Copyright © 2018 Gefran Soluzioni

Subject to change without notice

The information contained in this document is provided for informational purposes only. While efforts were made to verify the accuracy of the information contained in this documentation, it is provided "as is" without warranty of any kind.

Third-party brands and names are the property of their respective owners.

www.gefran.com/en/gefran-soluzioni

TABLE OF CONTENTS

1. PRODUCT OVERVIEW.....	5
2. STANDARDS AND APPROVALS	5
3. TECHNICAL SPECIFICATIONS.....	7
4. TECHNICAL DATA.....	8
4.1. Dimensions.....	8
4.2. Safety instruction.....	8
4.3. Installation Procedure	8
5. CONNECTIONS.....	9
5.1. Serial Port	9
5.2. Ethernet Port	10
5.3. Optional plugin module.....	10
5.4. Optional plugin module installation procedure	11
6. POWER SUPPLY, GROUNDING AND SHIELDING.....	12
7. BATTERY	13
8. SPECIAL INSTRUCTION FOR USE	13
8.1. Disclaimer.....	13
9. GETTING STARTED	13
10. SYSTEM SETTINGS.....	14
11. UNPACKING AND PACKING INSTRUCTIONS.....	15

INTRODUCTION

The operational guidelines described below is information which relates to the device, installation, transportation, storage, assembly, use and maintenance.

This Operating Instruction describes the main features of the Gefran Soluzioni srl GF Connect. The Manual refers to the following models:

GF Connect Embedded controller with 2 Ethernet port

SAFETY GUIDE

The manual contains safety standards that must be respected for the personal safety and to avoid damage.

Indications of attention are divided into three levels of severity:



DANGER: indicates a failure to observe safety rules and such failure may cause death or serious injuries.



ATTENTION: indicates a failure to observe safety rules and that deficiency may cause damage.



CAUTION: indicates a failure to observe safety rules and that deficiency may cause defects to the equipment or inconsistencies.

1. PRODUCT OVERVIEW

With the combination of GF Designer HD, and Gefran Cloud security, GF Connect offers companies the chance to start at an uncomplicated level in IoT and yet allows enormous future expansion into more complex aspects of Industry 4.0. Speaking across the vast library of GF Designer HD protocols as well as OPC UA to higher enterprise level control, the GF Connect is a true Plug and Use product. Straightforward wireless connectivity using the optional 2G/3G modem.

- Compatible with Existing Installations
- Compatible with GF Designer HD. Includes HTML5 access.

- Supports GF Designer HD protocols including OPC UA server and client.
- Compatible with Gefran Cloud secure remote connectivity.
- Compatible with 2G/3G modem.
- 2 Ethernet ports for network separation WAN/LAN.
- System settings by web browser.
- Linux-based open platform.

2. STANDARDS AND APPROVALS

The products have been designed for use in an industrial environment in compliance with the 2014/30/EU EMC Directive.

The products have been designed in compliance with:

EN 61000-6-4	CISPR 22	Class A
	CISPR 16-2-3	
EN 61000-6-2	EN 61000-4-2	
	EN 61000-4-3	
	EN 61000-4-4	
	EN 61000-4-5	
	EN 61000-4-6	
	EN 61000-4-8	
	EN 61000-4-11	
	EN 61000-4-29	
	EN60945	



cULus: UL61010-1 / UL61010-2-201
cULus: Class 1 Div 2

The installation of these devices into the residential, commercial and light-industrial environments is allowed only in the case that special measures are taken in order to ensure conformity to EN 61000-6-3.

The products are in compliance with the Restrictions on Certain Hazardous Substances (RoHS) Directive 2011/65/EU

In compliance with the above regulations the products are CE marked.

Product Identification

The product may be identified through a plate attached to the rear cover. You will have to know the type of unit you are using for correct usage of the information contained in the guide.

An example of this plate is shown in the figure below:

Note: the GF Connect label is used as an example for GF Connect series

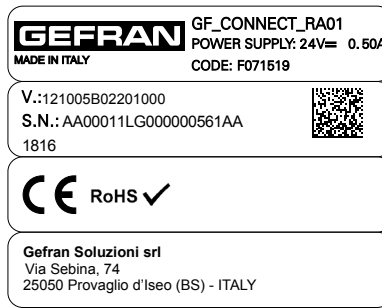
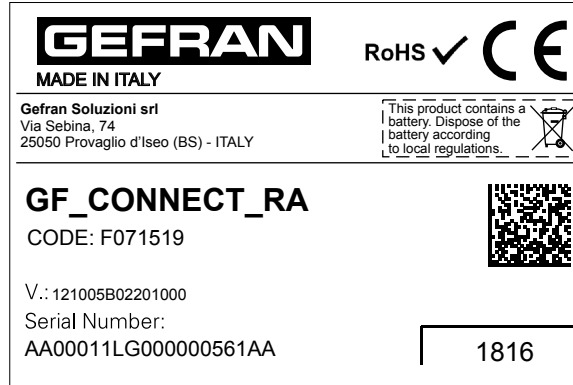

Product model name	GF Connect
Product part number	GF_CONNECT_RA
Code:	F071519
Year/week of production	1816
Serial Number	AA00011LG000000561AA
Version id of the product	121005B02201000
Manufacturer address	Gefran Soluzioni srl Via Sebina, 74 25050 Provaglio D'Iseo (Bs) - Italy

3. TECHNICAL SPECIFICATIONS

Back-up battery	3V 50mAh Lithium, rechargeable, not user-replaceable, model VL2330.	
Fuse	Automatic	
Serial Port	RS-232, RS-485, RS-422 software configurable	
Flash	4GB	
RAM	512MB	
Hardware clock	Clock/Calendar with back-up battery	
Accuracy RTC (at 25°C)	<100ppm	
ENVIRONMENTAL CONDITIONS		
Operating temperature (surrounding air temperature)	-20 ÷ +60°C (vertical installation) Plug-in modules and USB devices may limit max temperature to +50°C	EN 60068-2-14
Storage temperature	-20 ÷ +70°C	EN 60068-2-1 EN 60068-2-2 EN 60068-2-14
Operating and storage humidity	5 ÷ 85 % RH not-condensing	EN 60068-2-30
Vibrations	5 ÷ 9 Hz, 7 mm p-p 9 ÷ 150 Hz, 1 g	EN 60068-2-6
Shock	± 50 g, 11 ms, 3 pulses per axis	EN 60068-2-27
ELECTROMAGNETIC COMPATIBILITY (EMC)		
Radiated disturbance test	Class A	CISPR 22 CISPR 16-2-3
Electrostatic discharge immunity test	8 kV (air electrostatic discharge) 4 kV (contact electrostatic discharge)	EN 61000-4-2
Radiated, radio-frequency, electromagnetic field immunity test	80 MHz ÷ 1 GHz, 10V/m 1,4 GHz ÷ 2 GHz, 3 V/m 2 GHz ÷ 2.7 GHz, 1 V/m	EN 61000-4-3
Burst immunity test	± 2 KV dc power port ± 1 KV signal line	EN 61000-4-4
Surge immunity test	± 0,5 KV dc power port (line to earth) ± 0,5 KV dc power port (line to line) ± 1 KV signal line (line to earth)	EN 61000-4-5
Immunity to conducted disturbances induced by radiofrequency field	0.15 ÷ 80 MHz, 10V	EN 61000-4-6
Power frequency magnetic field immunity test	Enclosure, 50/60Hz, 30A/m	EN 61000-4-8
Protection class	IP20	EN 60529
Voltage dips, short interruptions and voltage variations immunity test	Port: AC mains; Level: 100% duration:	1 cycle and 250 cycles (50Hz); 1 cycle and 300 cycles (60Hz);
	40% duration:	10 cycles (50Hz); 12 cycles (60Hz);
	70% duration:	25 cycles (50Hz); 30 cycles (60Hz);
	Phase: 0°-180°	
Test executed on the 230Vac side of the Gefran Soluzioni Srl Power Supply		EN 61000-4-11
	Port: DC mains; Level: 0% duration:	10ms 20 spaces by 1s
Test executed on the 24Vdc of the EUT		EN 61000-4-29

4. TECHNICAL DATA

MODEL	GF Connect
Flash	4GB
SD card slot	yes
RAM	512MB
Serial Port	RS-232, RS-485, RS-422 software configurable
Ethernet port	2 10/100Mb
USB port	1 Host interface version 2.0 max. 500mA
Expansion slot	1 Optional Plugin
Battery	rechargeable
Real Time Clock	yes
Voltage	24Vdc (*)
Current rating (at 24VDC)	0.35A
Weight	0.6 Kg

(*) 10-32Vdc

For applications requiring compliance with EN 61131-2 and specifically in reference to 10 ms voltage dips, the power supply range voltage is 18-32Vdc.

4.1. Dimensions

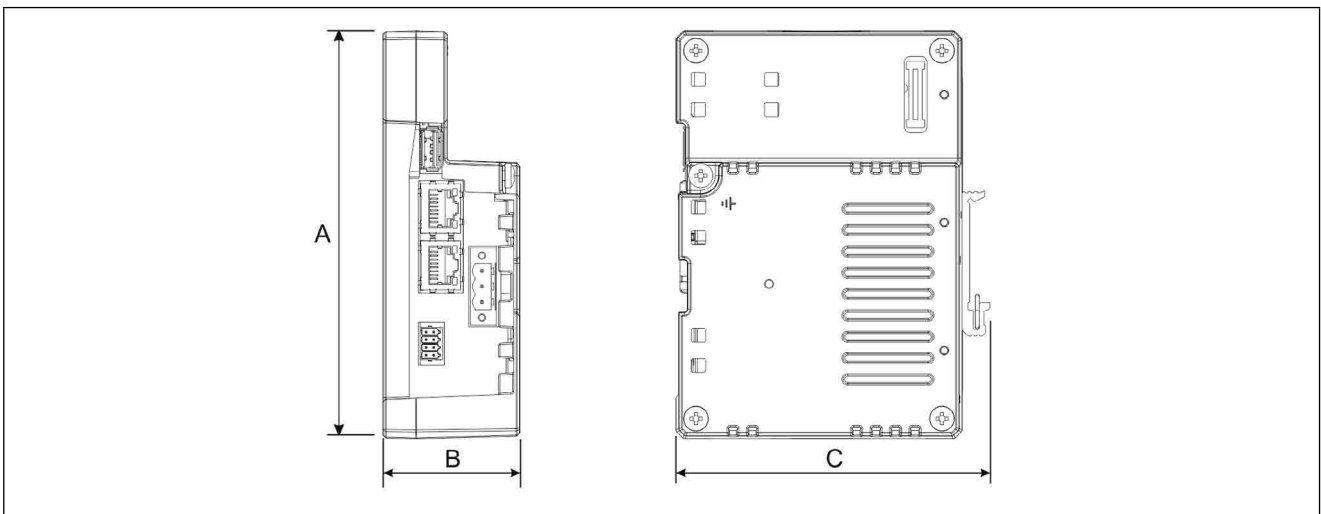

MODEL	A	B	C
GF Connect	134mm/5.27"	45mm/1.77"	103mm/4.05"

4.2. Safety instruction



For all installation notes, please refer to the Installation Guide provided with the product.

4.3. Installation Procedure

The GF Connect series must be mounted on a TS35 DIN rail

5. CONNECTIONS

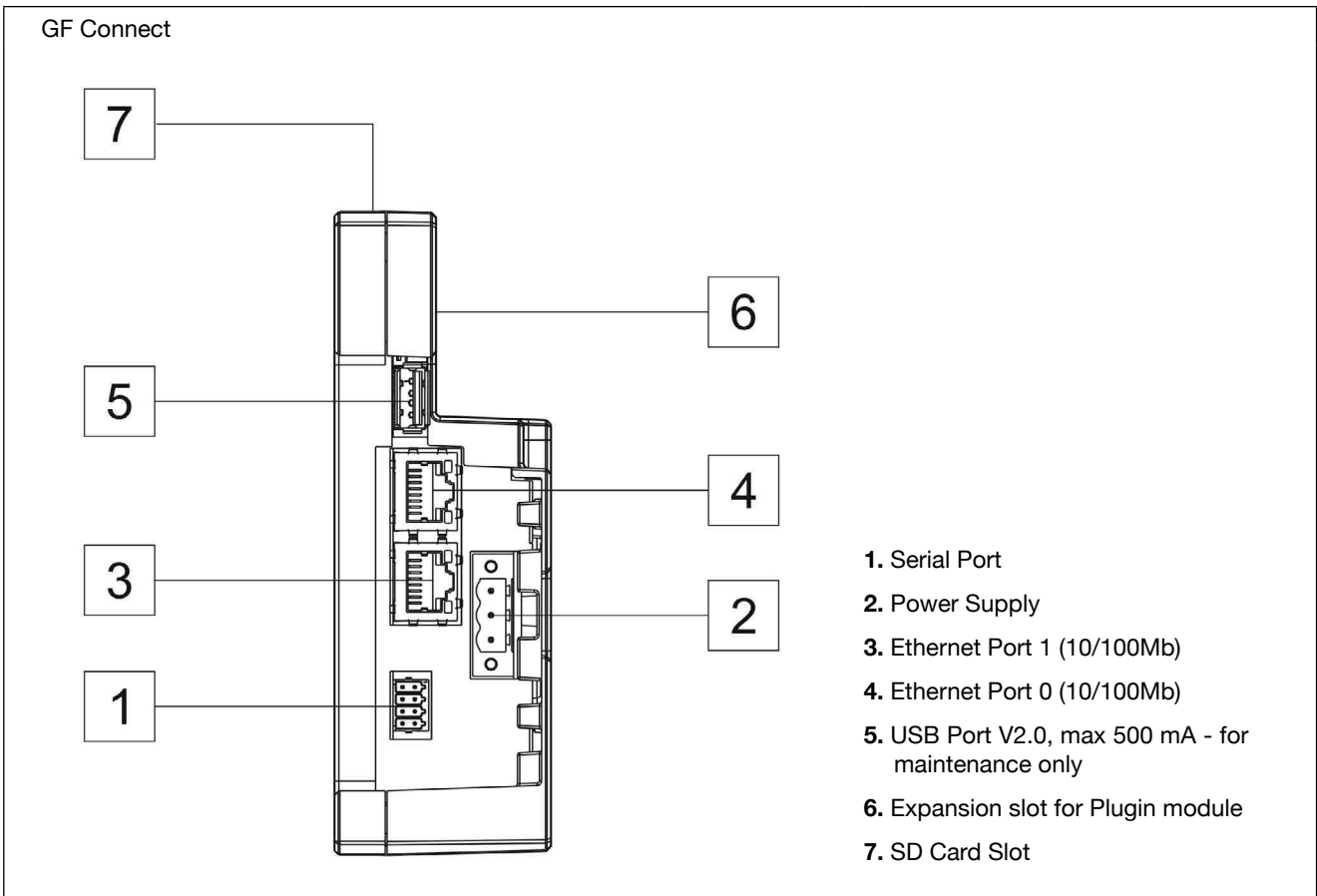
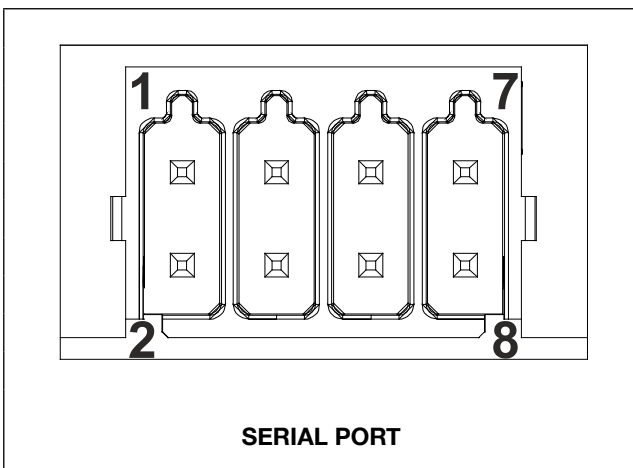

Figure 5.1

5.1. Serial Port

The serial port is used to communicate with the PLC or with another type of controller.
Different electrical standards are available for the signals in the PLC port connector: RS-232, RS-422, RS-485.

The serial port is software programmable. Make sure you select the appropriate interface in the programming software.



RS-232		RS-422, RS-485	
Pin	Description	Pin	Description
1	RX	1	CHB-
2	TX	2	CHA-
3	CTS	3	CHB+
4	RTS	4	CHA+
5	+5V output	5	+5V output
6	GND	6	GND
7		7	
8	SHIELD	8	SHIELD
		To operate in RS-485 pins 1-2 and 3-4 must be connected externally.	

The communication cable must be chosen for the type of device being connected

5.2. Ethernet Port

The Ethernet port have two status indicators. Please see description in figure.

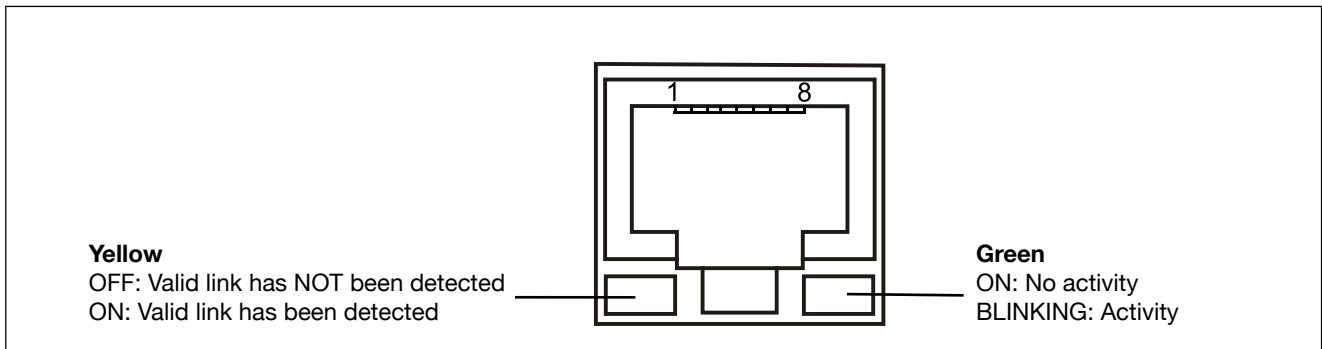

Factory settings:

ETH0 / WAN: DHCP
ETH1 / LAN: IP Address 192.168.0.1 Subnet mask: 255.255.255.0
Settings: https://192.168.0.1/machine_config
Username: admin
Password: admin

5.3. Optional plugin module

GF Connect series panels have several optional plugin module, multiple modules configurations are possible.

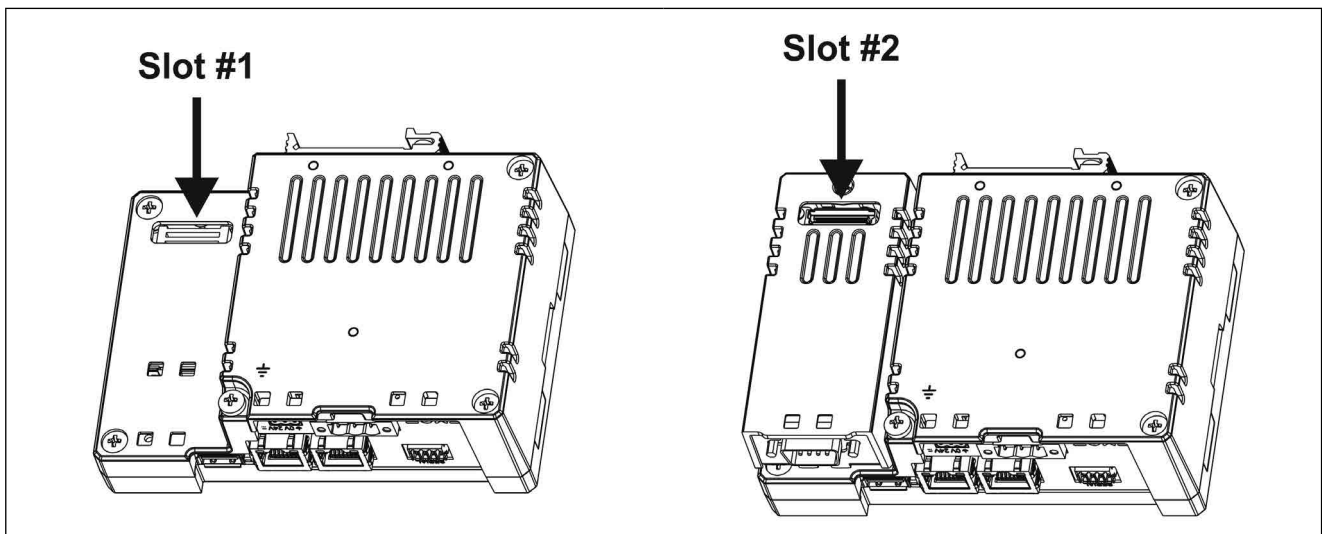

Slot#2 and Slot#4 are available only if plugin module has the “bus extension connector”.

Note: It is not possible to stack two modules that are using the same type of interface.

5.4. Optional plugin module installation procedure

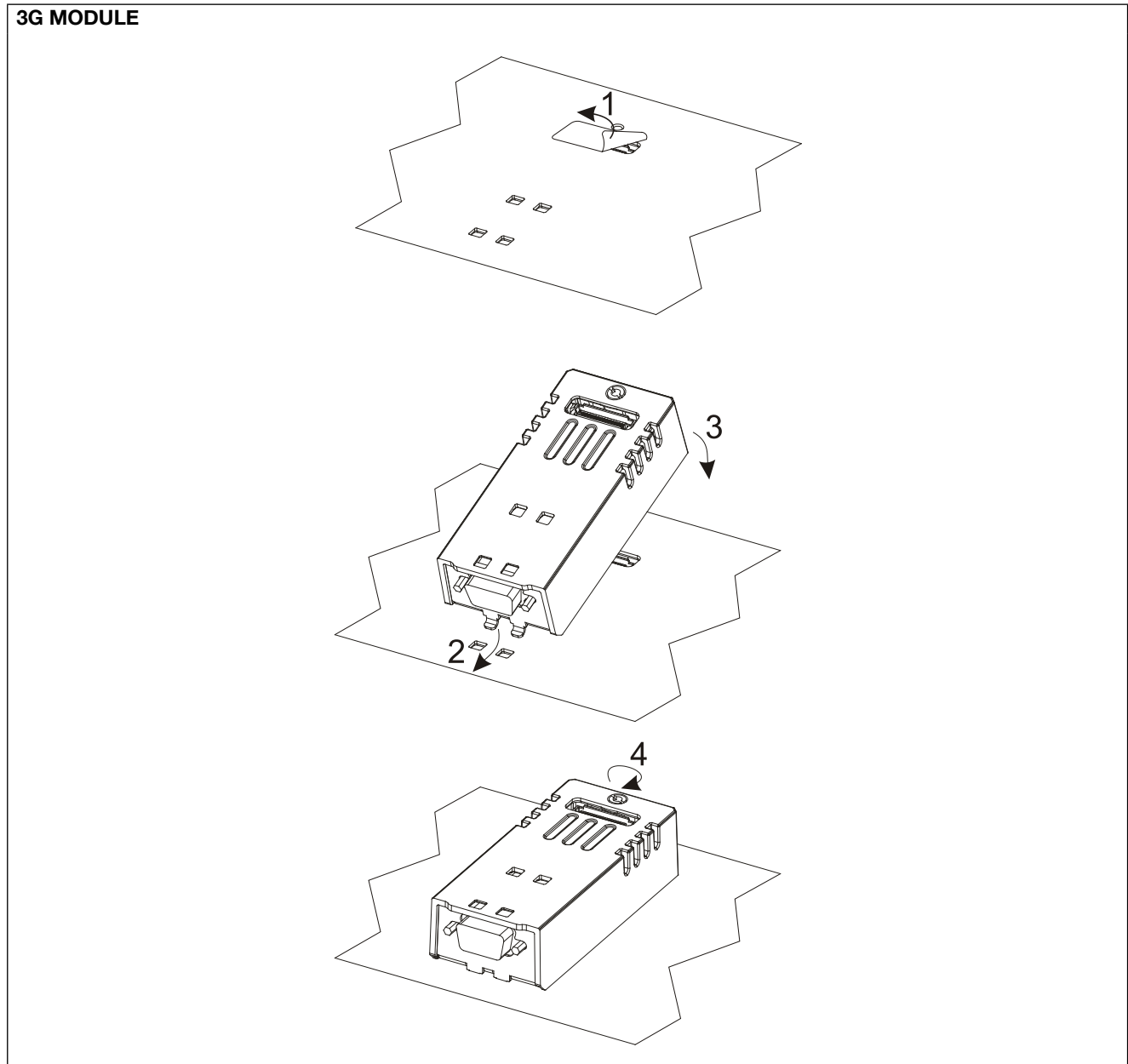

Below you can find relation between modules and max number of modules that can be used into G-Vision 66 e GF Connect panels, based on their Interface Type:

Module	Application	Max Modules	Interface Type	Bus Extension connector
GV_PLUG-CAN	CAN	2	CAN	Y
GV_PLUG-3G	3G modem	1		Y
GV_PLUG-232	Serial RS232	2	Serial	Y
GV_PLUG-485	Serial RS485	2	Serial	Y
GV_PLUG-LTE_WIFI_GPS	4G wireless modem	1		Y

Max modules refers to max number of modules can be plugged into the HMI (all slots).

If you are planning to use **GV_PLUG-232** and **GV_PLUG-485** (additional serial ports) you will obtain following "COM - Slot#" association:

- a module plugged in Slot#1 or into Slot#2 will be COM2,
- a module plugged in Slot#3 or into Slot#4 will be COM3.

If you are planning to use two **GV_PLUG-CAN** (CAN interface) you will obtain following Slot# association:

- a module plugged in Slot#1 or into Slot#2 will be the CanPort 0,
- a module plugged in Slot#3 or into Slot#4 will be the CanPort 1.

6. POWER SUPPLY, GROUNDING AND SHIELDING

The power supply terminal block is shown in the figure below.

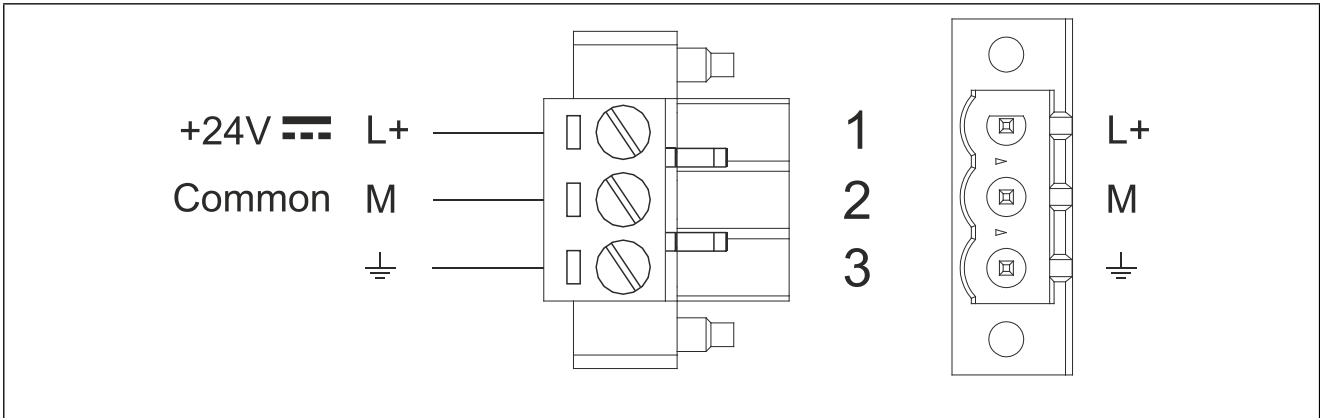

Figure 6.1

3 conductor 1,5mmq wire size minimum, minimum temperature conductor rating 105°C.

Note: Ensure that the power supply has enough power
The unit must always be grounded to earth with
limit the effects of noise due to electromagnetic

capacity for the operation of the equipment.
1,5mmq wire size minimum. Grounding helps
interference on the control system.

Earth connection will have to be done using either the screw or the faston terminal located near the power supply terminal block. A label helps identify the ground connection. Also connect to ground the terminal 3 on the power supply terminal block. The power supply circuit may be floating or grounded. In the latter case, connect to ground the power source common as shown in figure (see below) with a dashed line.

When using the floating power scheme, note that the panes internally connects the power common to ground with a 1MΩ resistor in parallel with a 4,7nF capacitor.

The power supply must have double or reinforced insulation.

The suggested wiring for the power supply is shown below.

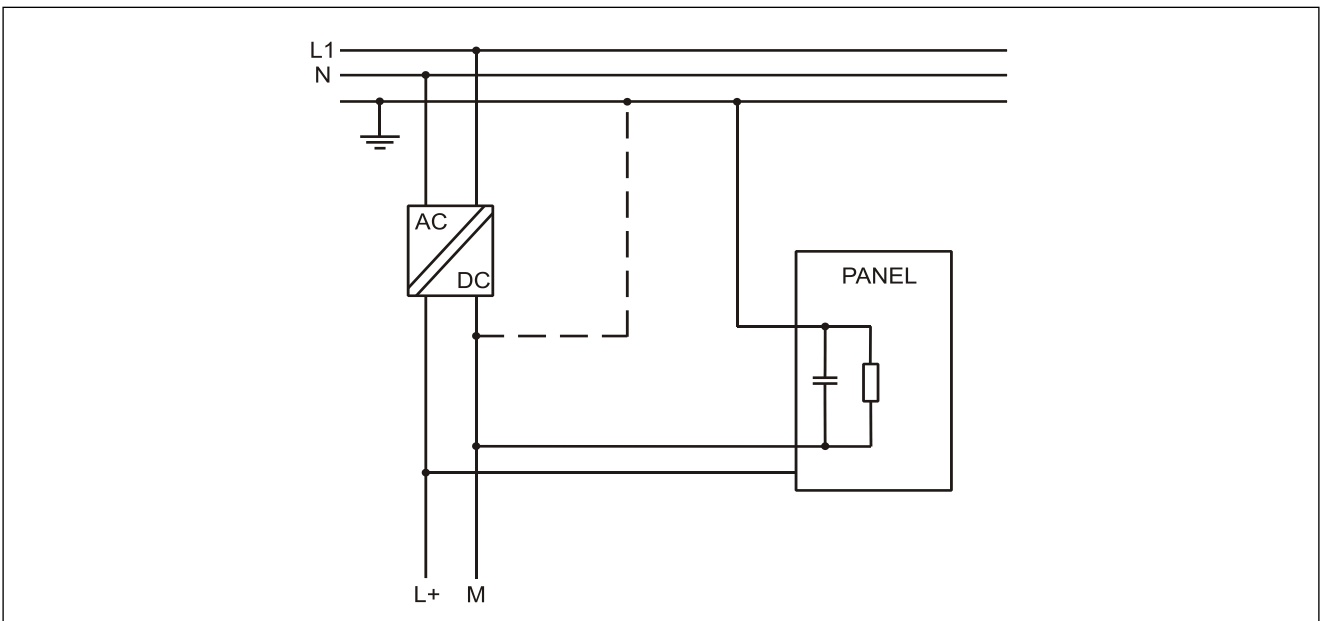

Figure 6.2

All the electronic devices in the control system must be properly grounded. Grounding must be performed according to applicable regulations.

7. BATTERY

These devices are equipped with rechargeable Lithium battery, not user-replaceable.

The following information is maintained by the battery:

- hardware real-time clock (date and time)

Charge:

At first installation must be charged for 48 hours.

When the battery is fully charged, it ensures a period of 3 months of data back-up at 25°C.

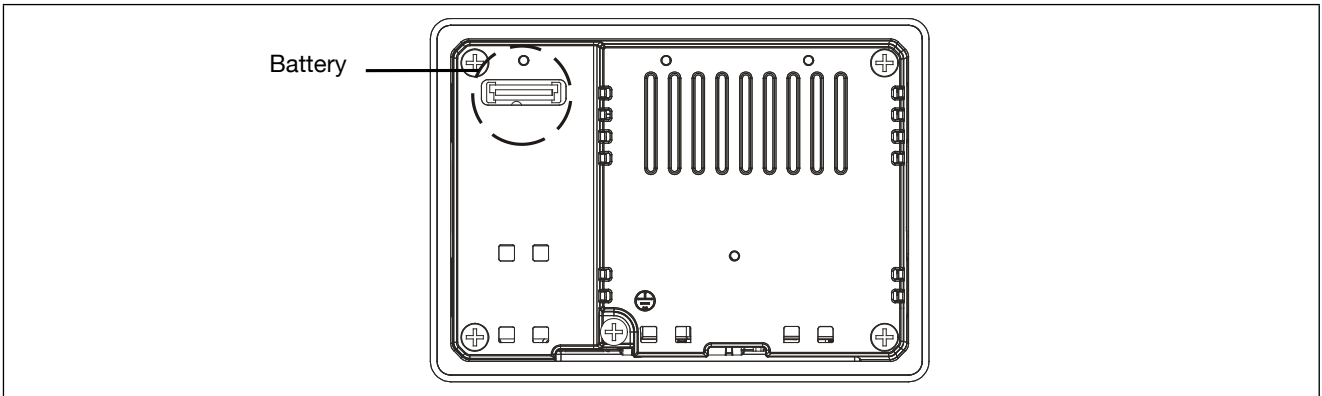

Figure 7.1 GF Connect



ATTENTION

Dispose of batteries according to local regulations.



ATTENTION

This device cannot be disposed of as a domestic waste but according to WEEE European Directive 2012/19/EU



8. SPECIAL INSTRUCTION FOR USE

- The equipment shall only be used in an area of not more than pollution degree 2, as defined in IEC/EN 60664-1.
- The equipment shall be installed in an enclosure that provides a degree of protection not less than IP 54 in accordance with IEC/EN 60079-15.
- Transient protection shall be provided that is set at a level not exceeding 140 % of the peak rated voltage value at the supply terminals to the equipment.
- Install the embedded controller according to the accompanying installation instructions.
- Ground the embedded controller according to the accompanying installation instructions.
- Only qualified personnel may install the embedded controller or repair it.
- Ensure that the aeration holes are not covered.
- This device should not be used for purposes and methods other than indicated in this document and in the documentation accompanying the product.

8.1. Disclaimer

Any remote connection functions shall be used only under adequate security conditions, in compliance with current regulatory provisions and only by properly trained personnel. The evaluation of such conditions is up to the user.

9. GETTING STARTED

Delivery configuration of software in GF Connect products is based on a loader. You may use the services of the loader to install applications on the device such as GF Designer HD runtime. Use System Settings to activate Cloud Service. Higher is required. GF Designer HD is a software tool that must be properly installed on a computer running Microsoft Windows.

There are two options to transfer a GF Designer HD application project to an GF Connect device:

- | | |
|----------|-------------------------------------------------------------------------------------------------------------------------------------------------------------------------------------------------------------------------------------------------------------------------|
| Ethernet | Connect the GF Connect to the computer with an Ethernet network. In GF Designer HD select the command Run/Download to target. You may have to ensure that the proper firewall policy has been configured in the computer to allow GF Designer HD to access the network. |
| USB | Create an Update Package using GF Designer HD and copy it to a USB Flash drive. |

10. SYSTEM SETTINGS

GF Connect series products have a system settings interface to allow configuration of system options. The user interface of System Settings is based on HTML pages accessible remotely using a Web browser Chrome v44 or higher at port 443.

To connect enter the address https://IP/machine_config where IP is the IP address of the GF Connect device. Default username is “admin”, default password is “admin”. Use navigation menu on left side of the screen to browse through available options.

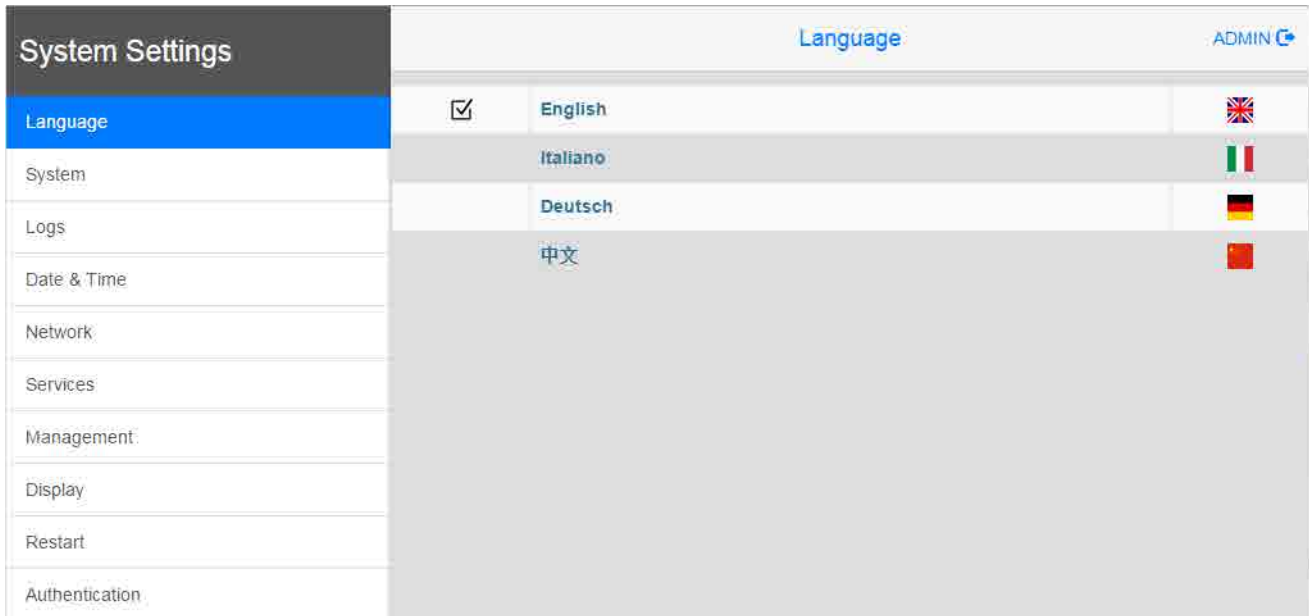

The active item of menu is highlighted on the left side of the screen. The right side shows related information and settings.

System Settings has two modes of operation:

User Mode GF Designer HD runtime or Cloud Service is running or the device is in “factory default” status.
System Mode GF Designer HD runtime or Cloud Service is not running or the device has a software failure. System Mode includes all options available in User Mode and additionally includes commands dedicated to system upgrade and recovery not available when running in User Mode.

System Settings includes options for basic settings of the device:

Language Configure language used for System Setting menu only.

System Show information about platform, status and timers (like System on time, backlight on time).

Logs Enable persistent log for BSP and allows exporting it.

Date & Time Change the device date and time, including time zone and NTP Server

Network Configure IP Address of Ethernet interfaces and other network settings such as DNS, Gateway, DHCP, Hostname, routing and bridging.

Services Enable/disable services. Examples of services are: SSH server, Bridge, Cloud, Router, SNMP and logging.

Management Update of BSP components (Main OS, Config OS, Boot loader, XLoader), check for partitions consistence, update of splash screen, information about usage and size of partitions. The update of Main OS is available only in System Mode, the update of Config OS is only in User Mode.

Restart Restart the device. “Main OS” option restarts the device in User Mode, “Config OS” option restarts the device in System Mode showing System Settings.

Authentication Configure password for administrator (“admin”) and for the standard user (“user”). Administrator has full access to System Settings (updates of BSP and other system components). Standard user has some limitations.

Note: Additional information on System Settings are available in dedicated manual
<https://www.gefran.com/gefrancloud/>.

11. UNPACKING AND PACKING INSTRUCTIONS

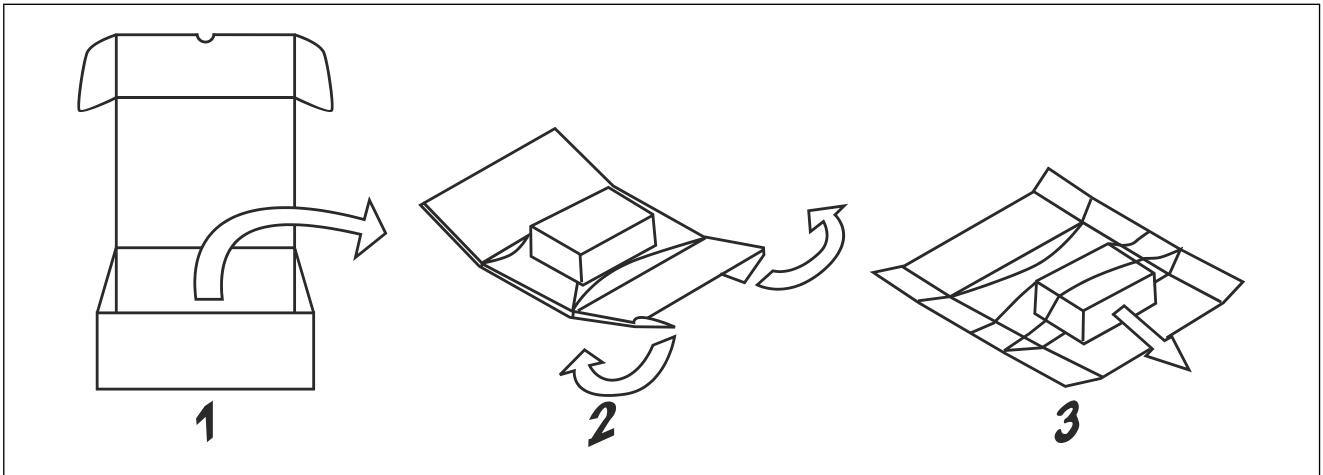

To repack the unit, please follow the instructions backwards.

GEFRAN

Gefran Soluzioni srl
Via Sebina 74 - 25050 Provaglio d'Iseo (BS) Italy
Tel. +39 0309888.1 - Fax +39 0309839063 - info@gefran.com
<http://www.gefran.com>
www.gefran.com/en/gefran-soluzioni