

JUMO exTHERM-DR

Two-State Controller According to ATEX and IECEx



Type 701055/8-23-044



Type 701055/8-23-045

Operating Manual

70105500T90Z001K000

JUMO

V7.00/EN/00644471/2025-05-05

Operating overview

Normal display (approx. 10 secs after switch on)

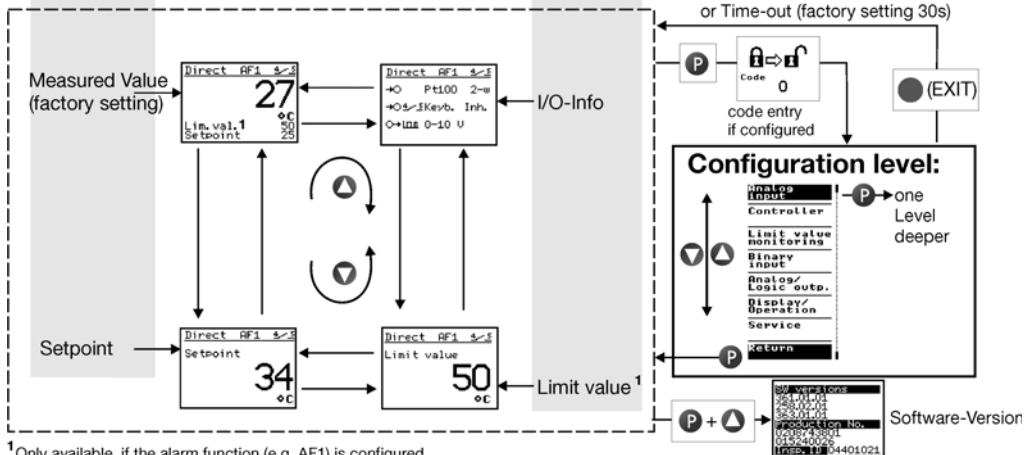

¹ Only available, if the alarm function (e.g. AF1) is configured.
 This Limit value, is used as distance to the setpoint in case of alarm functions AF1...AF6 or fixed setpoint in case of alarm functions AF7 and AF8.

Content

	Operating overview	2
1	Brief description	9
1.1	Safety information	10
2	Identifying the device version	11
2.1	Scope of delivery	12
2.2	Device software versions	13
2.3	Fabrication number	13
2.4	Service addresses	13
2.5	Approvals	14
3	Mounting	16
3.1	Dimensions	16
3.2	Mounting site, DIN-rail mounting	17
3.3	Close mounting	17
3.4	Dismounting	18
3.5	Galvanic isolation	19
3.6	Use of the setup interface	19
4	Electrical connection	20
4.1	Installation notes	20
4.2	Removing the protective cap	21
4.3	Connection diagram	22
4.4	Checking wiring of the intrinsically safe electrical circuit	25
5	Startup of the device	26
5.1	Display and control elements	26

5.2	Setting the display after device is switched on	26
5.3	Selecting and editing parameters	28
5.4	Canceling edit	28
5.5	Sealing the device	29
6	ATEX ignition protection type "i"	31
6.1	Intended use	31
6.1.1	Installation regulations	32
6.2	Identification marking according to ATEX directive 2014/34/EU:	32
6.3	Meaning of the X character in the type examination certificate.	34
6.4	Associated, intrinsically safe electrical apparatus according to EN 60079-11	35
6.4.1	Function of intrinsic safety	35
6.4.2	Probe arrangement in the Ex-area	37
6.4.3	Explanation of probe temperature classes	39
7	ATEX ignition protection type "e" and "t"	41
7.1	Intended use	41
7.2	Ex e identification marking in accordance with EN 60079-7:	41
7.2.1	Probe arrangement in the Ex-area	43
8	IECEx	44
8.1	Intended use	44
8.2	IECEx identification marking in accordance with IEC standards:	44
8.3	IECEx identification marking ignition protection type "e" and "t"	45
8.4	Excerpt of important device data.	46
9	Configuration level	49
9.1	Navigation principle	49

Content

9.2	Analog input	50
9.2.1	Sensor type	50
9.2.2	Offset	51
9.2.3	Lead wire resistance	51
9.2.4	Filter time	51
9.2.5	Scaling start	51
9.2.6	Scaling end	51
9.3	Controller	52
9.3.1	Control direction	52
9.3.2	Setpoint value	53
9.3.3	Hysteresis setpoint value	53
9.3.4	Setpoint value min.	53
9.3.5	Setpoint value max.	53
9.4	Limit value monitoring	54
9.4.1	Alarm function	54
9.4.2	Limit value	57
9.5	Digital input	58
9.5.1	Function	58
9.4.3	Hysteresis limit value	58
9.4.4	Error signal	58
9.6	Analog/logic output	59
9.6.1	Function	59
9.6.2	Signal type	59
9.6.3	Scaling start	59
9.6.4	Scaling end	59
9.6.5	Error signal	60
9.6.6	Logic output	60

9.6.7	Behavior when leaving the scaling range	.61
9.7	Display/operation	.62
9.7.1	National language	.62
9.7.2	Unit	.62
9.7.3	Decimal place	.62
9.7.4	Normal display	.62
9.7.5	Contrast	.62
9.7.6	Lighting	.63
9.7.7	Timeout light	.63
9.7.8	Timeout operation	.63
9.7.9	Code	.63
9.8	Service	.64
9.8.1	Limit switching operation	.64
9.8.2	Current switching operations	.64
9.8.3	Operating hours	.65
10	Technical data	.67
10.1	Analog inputs	.67
10.2	Analog output	.70
10.3	Digital input	.70
10.4	Relay outputs	.70
10.5	Measuring circuit monitoring	.71
10.6	Voltage supply	.71
10.7	Test voltages according to EN 60730, Part 1	.72
10.8	Electrical safety	.72
10.9	Environmental influences	.72

Content

10.10	Housing	73
10.11	Note about suitable probes	73
10.12	Note about probes in Chapter 10.13 up to Chapter 10.15	73
10.12.1	Recommended tests for temperature probes	74
10.13	Probes for the operating medium air	75
10.14	Probes for water and oil	76
10.15	Probes for air, water, and oil	78
11	Setup program	79
11.1	Minimum hardware and software requirements:	79
11.2	Displaying the device software version	79
11.3	Forgotten the code?	80
11.4	Special function: thermocouple reverse polarity protection	80
12	Alarm messages	81
13	Error messages	82
14	What to do, if ...	87
15	Behavior of Outputs	89
16	Certificates	91
16.1	ATEX TÜV Nord	92
16.2	IECEX TÜV Nord	99
16.3	IECEX Eurofins	108
16.4	Ex „e“ und „t“	113
16.5	EU-declaration of conformity	117

17	China RoHS	123
----	------------------	-----

1 Brief description

The device is tested according to ATEX directive 2014/34/EU and IECEx as associated apparatus with intrinsically safe output. It meets the requirements of the following identification markings (**blue** terminals):



II (1) G [Ex ia Ga] IIC

II (1) D [Ex ia Da] IIIC

The input is intrinsically safe [Ex ia] so that relevant type-tested probes can be connected directly. Barriers are no longer required.

The device meets the requirements of the following identification marking (**black** terminals):



II (2) G [Ex eb Gb] IIC





II (2) D [Ex tb Db] IIIC

The measured value at the analog input can be recorded by various probes or standard signals.

It is compared with the setpoint value and switches the **relay output controller K1** (LED K1 lights up) depending on the controller function.

A limit value exceedance is signaled by the installed **relay output limit value K2** (LED K2 lights up).

1.1 Safety information

Symbol	Meaning	Explanation
	Note	This symbol refers to important information about the product, its handling, or additional benefits.
	Danger	This symbol indicates that personal injury from electrocution may occur if the appropriate precautionary measures are not taken.
	Caution	This symbol is used in conjunction with the signal word to indicate that personal injury may occur if the instructions are disregarded or not followed correctly.
	Read	This text contains important information which must absolutely be read before proceeding. Manipulations not described in the operating manual or which are expressly forbidden will jeopardize your warranty rights.
	Reference	This symbol refers to further information in other manuals, chapters, or sections.
abc ¹	Footnote	Remarks at the end of a page that refer to specific text passages and are marked with a number placed in superscript.
*	Action instruction	This symbol marks the description of a required action . The individual steps are marked by this asterisk.

2 Identifying the device version

Exemplary illustration of the type plate, which is glued on the side of the device.



**AC voltage supply
110 to 240 V:**

JUMO GmbH & Co. KG Fulda, Germany
www.jumo.net

JUMO exTHERM-DR
Typ: 701055/8-23

SW: 361.01.01 / 258.02.01. / 363.01.01

⊕ 3A, 230VAC - ohm. Last
~ AC 110...240V, +10/-15%, 48...63Hz, 12VA

F-Nr: 000000001001010000 TN: 00647887



**AC/DC voltage supply
20 to 30 V:**

JUMO GmbH & Co. KG Fulda, Germany
www.jumo.net

JUMO exTHERM-DR
Typ: 701055/8-25

SW: 361.01.01 / 258.02.01. / 363.01.01

⊕ 3A, 230VAC - ohm. Last
~ AC/DC 20...30V, 48...63Hz, 12VA

F-Nr: 000000001001010000 TN: 00647885

Ex i identification marking

JUMO GmbH & Co. KG 36039 Fulda
Germany
www.jumo.net

JUMO exTHERM-DR

 II (1) G [Ex ia Ga] IIC
II (1) D [Ex ia Da] IIC

TÜV 15 ATEX 163874 X

 [Ex ia Ga] IIC
[Ex ia Da] IIC
IECEx TUN 16.0022X

Klemmen / Terminals / Borne 1, 2, 3:
 $U_0 = 6,0 \text{ V}$ $C_0 = 36,3 \mu\text{F}^*$
 $I_0 = 41,2 \text{ mA}$ $L_0 = 20 \text{ mH}^*$
 $P_0 = 61,8 \text{ mW}$ * see certificate
 $0^\circ\text{C} \leq T_a \leq +55^\circ\text{C}$

Ex e and Ex t identification marking

JUMO GmbH & Co. KG 36039 Fulda
Germany
www.jumo.net

JUMO exTHERM-DR

 II (2) G [Ex eb Gb] IIC
 II (2) D [Ex tb Db] IIC

SEV 17 ATEX 0177 X

Klemmen / Terminals / Borne 1, 2, 3:
 $U_0 = 6,0 \text{ V}$
 $I_0 = 41,2 \text{ mA}$
 $P_0 = 61,8 \text{ mW}$
 $0^\circ\text{C} \leq T_a \leq +55^\circ\text{C}$



The voltage supply that is connected must correspond to the voltage specified on the nameplate!

701055				Basic type exTHERM-DR
	8			Version Default setting
	9			Configured acc. to customer specifications
		23		Voltage supply AC 110 to 240 V +10 % /-15 %, 48 to 63 Hz
		25		AC/DC 20 to 30 V, 48 to 63 Hz
			044	Ignition protection type [Ex ia] associated apparatus, installation outside the Ex-area
			045	[Ex eb, tb] associated apparatus, "eb" for gas, "tb" for dust, installation outside the Ex-area
701055 /	8 -	23 -	044	

2.1 Scope of delivery

- JUMO exTHERM-DR in the ordered version
- Operating manual
- Protective cap ATEX for analog input (blue)

2.2 Device software versions

Display module version: 361.01.01
Analog channel 1 version: 258.02.01
Unlocking module: 363.01.01



```
SW versions
361.01.01
258.02.01
363.01.01
Production No.
0208743801
015240026
Insp. ID 04401021
```

2.3 Fabrication number

The fabrication number is displayed on the device.

* Press **P** + **▲** keys

Setup:

The first 8 digits are the order production number: 01939251
Digit 9 and 10 manufacturing site Fulda: 01
Digit 11 (second row) hardware version: 0
Digit 12 and 13 year: 2014
Digit 14 and 15 calendar week: 16
Digit 16 to 19 consecutive number: 0045







```
SW versions
361.01.01
258.02.01
363.01.01
Production No.
0208743801
015240026
Insp. ID 04401021
```

2.4 Service addresses

See back cover

2.5 Approvals

	<p>Designation Testing agency Certifikate no. Inspection basis Valid for</p>	<p>ATEX „i“ TÜV Nord TÜV 15 ATEX 163874 X Directive 2014/34/EU Devices with blue terminals, Ignition protection level 044</p>
	<p>Designation Testing agency Certifikate no. Inspection basis Valid for</p>	<p>ATEX „e“ und „t“ Eurofins / Electrosuisse Product Testing AG SEV 17 ATEX 0177 X Directive 2014/34/EU Devices with black terminals, Ignition protection level 045</p>
	<p>Designation Testing agency Certifikate no. Inspection basis Valid for</p>	<p>IECEX „i“ TÜV Nord IECEX TUN 16.0022X IEC 60079-0, IEC 60079-11 Devices with blue terminals, Ignition protection level 044</p>
	<p>Designation Testing agency Certifikate no. Inspection basis Valid for</p>	<p>IECEX „e“ and „t“ Eurofins Electrosuisse Product Testing AG IECEX SEV 22.0017X IEC 60079-0, IEC 60079-7, IEC 60079-31 Devices with black terminals, Ignition protection level 045</p>



This operating manual is the translation of the **German manual**.

It is valid for the following hardware and software versions:

Display module from version: 361.01.01

Analog channel 1 from version: 258.02.01

Unlocking module from version: 363.01.01

* Press **P** + **▲** keys

Keep the operating manual in a place that is accessible to all users at all times.



All the necessary settings are described in the operating manual. Manipulations that are not described in the operating manual or which are expressly forbidden will jeopardize your warranty rights and may render the safety function inoperative!

Any interference with the inside of the device is prohibited!

Repairs may only be performed by JUMO in the company's headquarters in Fulda.

If you have any problems, please contact the nearest branch office or the head office.

3 Mounting

3.1 Dimensions

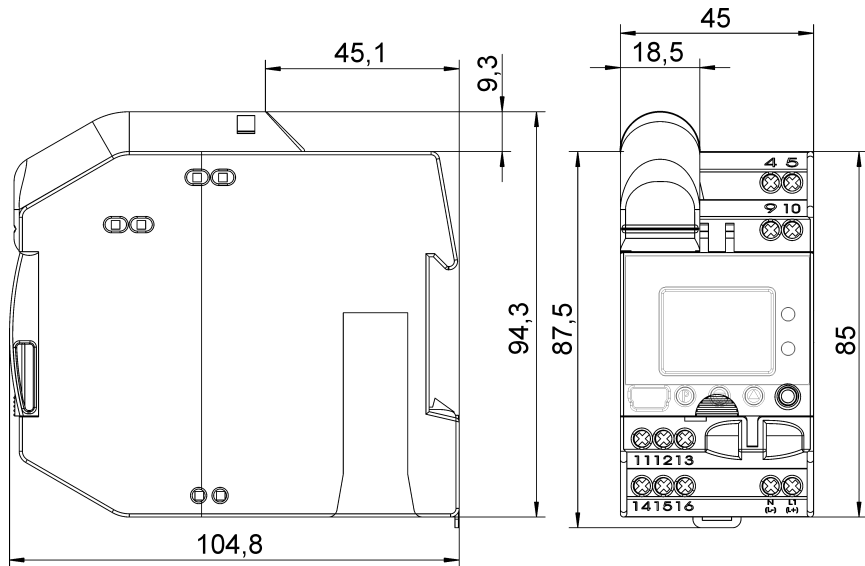

3.2 Mounting site, DIN-rail mounting



The device is not suitable for installation in potentially explosive areas.

⇒ Chapter 6.1 "Intended use"

The device is clipped to a 35 mm DIN rail (DIN EN 60715) from the front and locked into place by pressing downwards.

- ⇒ The ambient conditions at the mounting site must meet the requirements specified in the technical data.
Chapter 10 "Technical data"

- The mounting site should be as vibration-free as possible to prevent the screw connections from working loose.
- The mounting site should be free from aggressive media (e.g. strong acids and lyes), and as free as possible from dust, flour, or other suspended matter to prevent blocking of the cooling slots!

3.3 Close mounting

- Maintain the minimum distance of 20 mm to the top and the bottom.
 1. So that the release slot can still be accessed with a screwdriver from the bottom.
 2. So that when dismantling, the device can be swiveled upwards and removed from the DIN rail.
- Several devices can be mounted right next to one another without a minimum distance.



3.4 Dismounting

- * Place screwdriver in release catch and press upwards (1).
- * Swivel screwdriver and housing upwards at the same time out of the DIN rail (2).

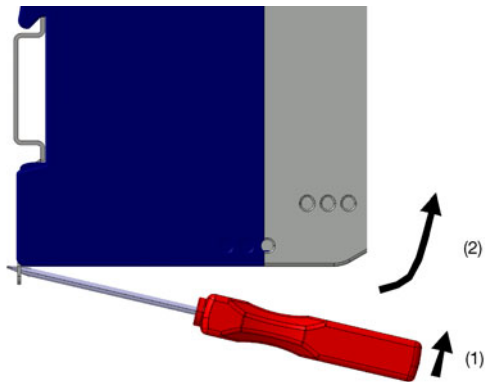

3.5 Galvanic isolation

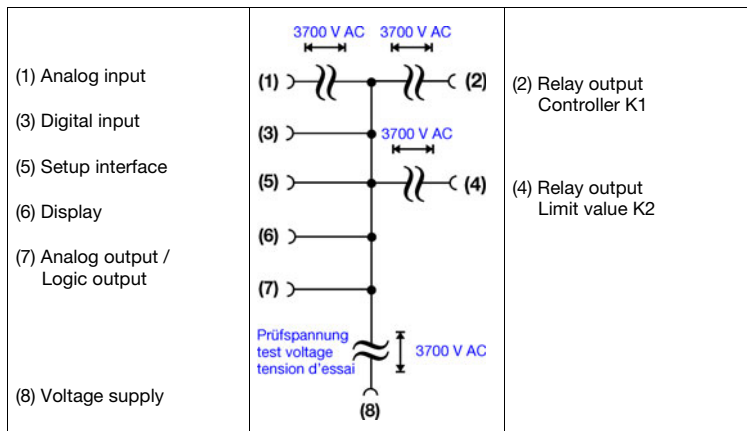

3.6 Use of the setup interface

- The USB setup interface is only designed for service use over a limited period (such as the transfer of setup data or during startup).
- It is not suitable for unlimited operation of the interface in a fixed installation.

4 Electrical connection

4.1 Installation notes

- Check to see if the exTHERM-DR 701055 is installed in a manner appropriate to the application (temperature measurement) and that it is operated within the admissible plant parameters.
- The device is intended to be installed in control cabinets, machines, or plants. Ensure that the customer's fuse protection does not exceed 20 A.
- Disconnect the device from the mains voltage on all poles prior to starting service or repair work.
- All incoming and outgoing lines without a connection to the power supply network must be laid with shielded and twisted lines. The shield must be grounded on the device side.
- Do not lay the input and output cables close to components or lines through which current is flowing.
- Do not connect any additional loads to the screw terminals for the voltage supply of the device.
- Both the choice of cable material for the installation, as well as the electrical connection of the device must conform to the local requirements of VDE 0100 "Regulations on the Installation of Power Circuits with Nominal Voltages below 1000 V" or the appropriate regulations for the country.
- Suitable measures must be taken to protect the relay circuit. The maximum switching capacity is 230 V/3 A (resistive load).
- The electromagnetic compatibility conforms to the standards and regulations cited in the technical data.
⇒ Chapter 10 "Technical data"



Hybrid mixtures:

If a dangerous atmosphere could occur at the mounting site – an atmosphere that is potentially explosive due to a mixture of gases, steam, or mist and at the same time through combustible dusts – then the safety-related characteristic parameters of the gases, steam, or mist and the combustible dusts can change.

In such cases the suitability of the intended device is to be checked by an appropriate expert body.



The electrical connection and the configuration settings up to the startup must only be carried out by qualified personnel.

4.2 Removing the protective cap

- | | |
|---|---|
| 1 | * Insert the screwdriver into the right opening of the protective cap and pry up to the left. |
| 2 | * Hold the protective cap and pry up the second catch in the left opening to the right. |

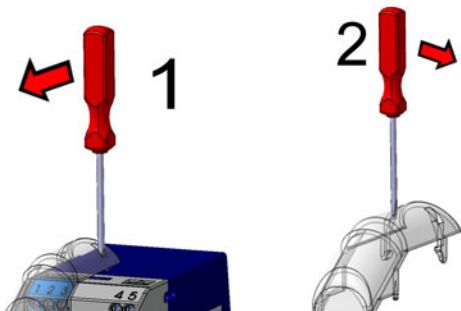

4.3 Connection diagram

The connection is made via screw terminals.



Caution:







The protective cap must be removed prior to wiring and put back on when finished.



This is necessary for the proper operation of the probes in the Ex-area!

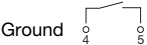

Wire	Admissible cross section
1-wire	$\leq 2.5 \text{ mm}^2$
Fine-strand, with ferrule	$\leq 1.5 \text{ mm}^2$

Tightening torque of the screws: max. 0.5 Nm

Legend	Comment	Screw terminals	Screw terminals
1, 2		Analog input 1 (E1)	Analog input 2 (E2)
	Thermocouple /		Terminals 6, 7, and 8 are not used.
	RTD temperature probe Pt100/Pt1000 in two-wire circuit		Terminals 6, 7, and 8 are not used.
	 Enter the line resistance for RTD temperature probes in two-wire circuit when using greater line lengths. ⇒ <i>Analog input</i>		
	RTD temperature probe Pt100/Pt1000 in 3-wire circuit		Terminals 6, 7, and 8 are not used.
	4 to 20 mA		Terminals 6, 7, and 8 are not used.
4	Digital input Connection to a potential-free contact		
5	Analog output / logic output: 0 to 20 mA 4 to 20 mA (factory set) 0(2) to 10 V		

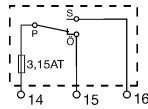
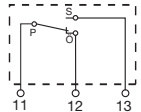
Legend	Comment	Screw terminals	Screw terminals
9	Voltage supply Acc. to nameplate	AC: L1 line conductor N neutral conductor 	DC: (L+) (L-) 
10	Relay output controller K1 (zero-current state) Relay (changeover contact) with fuse cut-out		
11	Relay output limit value K2 (zero-current state) Relay (changeover contact)		

4.4 Checking wiring of the intrinsically safe electrical circuit

**Caution:**

The protective cap that is removed prior to wiring must be put back into place after wiring is complete so that the detent lugs snap back into place!

This is necessary for the proper operation of the probes in the Ex-area!

**Caution:**

All screw terminals in the housing must always be tightened to the maximum torque of 0.5 Nm. This also applies to connections that are not required.

- * Fine-strand lines in ferrules up to max. 1.5 mm² or single-strand lines up to max. 2.5 mm² can be inserted and tightened.
- * Switch on the device and test whether the measured value of your choice (e.g. temperature or pressure) is displayed without any problems.
- * Place the protective cap back in its position and make sure it is securely in place.

5 Startup of the device

5.1 Display and control elements

- * When the voltage supply is set up, a testing routine starts during which all LEDs blink and the backlight display shows white pixels for 2 s and black pixels for 2 s.

After the testing routine is complete the device displays the measured value (default setting).

⇒ If an alarm or error message appears, refer to Chapter 12 "Alarm messages".

5.2 Setting the display after device is switched on

⇒ Chapter 9.7.4 "Normal display"

The main measured value appears on the screen in German (default setting). The example shows the screen layout of a controller with direct switching behavior at a setpoint value of 34 °C and limit value monitoring of 50 °C.



If the measured value is within the hysteresis at "Power ON", the relay outputs **controller K1** and **limit value K2** are set to inactive.

(1) Control direction of the controller

(7) Measured value

(6) Limit value



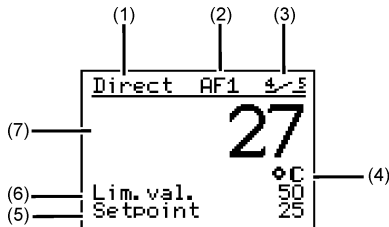

(5) Setpoint value



(2) Alarm function

(3) Digital input

(4) Unit



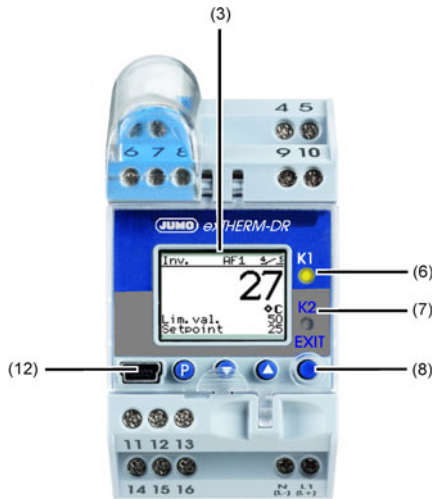









Legend	Comment
3	LCD display Black/white with background lighting, 96 x 64 pixels
6	LED K1 (yellow) Lights up when the relay output controller K1 is active.
7	LED K2 (yellow) Lights up when the relay output limit value K2 is active.
8	Keys (can only be operated when the transparent hood is folded upward) <ul style="list-style-type: none">  Value increase / previous parameter  Value reduction / next parameter  Programming  (EXIT)
12	Setup interface



5.3 Selecting and editing parameters

In the normal display, the values are switched using  or  and are only displayed.

To edit a value, for example here the setpoint value, carry out steps 1 to 4

1	Press 		The first menu item "Analog inputs" is highlighted in black. The vertical line to the right shows the current position in the menu.
2	Use  to select the controller Switch to submenu with 		
3	Press  1x until the setpoint value appears Press  (setpoint value flashes)		
4	Set the value of your choice with  or  Use  to acknowledge The value is adopted and saved.		Back to the normal display: With  (EXIT) or menu item "back" or automatically after timeout
	If no key is pressed for 30 seconds (timeout) then the device automatically returns to normal display and the value is not stored. The duration of the timeout can be configured. ⇒ See Chapter "Operating overview" on the first inner page of this manual		

5.4 Canceling edit

 (EXIT) is used to cancel editing and the previous value remains.

5.5 Sealing the device

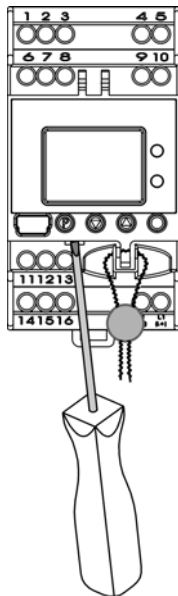

There is a lead-sealed see-through cover to prevent unintentional or unauthorized adjustment.

Two holes are provided to the left and right of the see-through cover through which wire can be guided for lead sealing to connect the cover to the housing. The wire ends are secured with the seal.

Opening see-through cover for close mounting:

A screwdriver can be used to pry open the see-through cover.

6 ATEX ignition protection type "i"

6.1 Intended use

The JUMO exTHERM-DR is a device designed in accordance with Directive 2014/34/EU, chapter 1, article 1, paragraph (b), intended for measuring temperatures, or other physical measurands such as pressure, directly through resistance sensors or thermocouple sensors, and using an adequate transmitter and 4-20 mA current input.

The stipulations and requirements for use specified in this document must be taken into consideration. All specifications below with regard to probes or sensor technology relate to the probes listed in Chapter 10.13 to Chapter 10.15. If other probes are used, their suitability must first be tested.



Important information:

Thermocouples should be evaluated with at least the requirements of EN 60584 or DIN 43710. RTD temperature probes should be evaluated with at least the requirements of EN 60751. Parameter values such as response rate, temperature stability, age drift, self-heating behavior, failure rates, fault models, etc. should likewise be taken into account.

The JUMO exTHERM-DR is associated apparatus that may only be used outside the Ex-zone.

Another use or one that goes beyond the specified use ? with respect to use in potentially explosive areas ? is considered as not being in accordance with the intended use.

Liability for resulting damages cannot be assumed.

The JUMO exTHERM-DR has been manufactured in compliance with applicable standards and directives, as well as applicable safety regulations. Nevertheless, improper use may lead to personal injury or material damage.

To avoid danger, the JUMO exTHERM-DR may only be used:

- For the intended use
- When in good order and condition
- Under consideration of this operating manual

**DANGER!**

Ex approval becomes null and void in the event of incorrect use of the JUMO exTHERM-DR or non-compliance with the safety requirements of this operating manual.

6.1.1 Installation regulations

If electrical apparatus is used in plants and ambient conditions with greater safety requirements, the obligations of the applicable installation regulations according to EN 60079-14 "Explosive atmospheres – Part 14: Electrical installations design, selection and erection" are to be considered along with other applicable requirements.

6.2 Identification marking according to ATEX directive 2014/34/EU:



II (1) G [Ex ia Ga] IIC

II (1) D [Ex ia Da] IIIC

Type: 701055/...-044 [Ex i]



II (1) G [Ex ia Ga] IIC
 II (1) D [Ex ia Da] IIIC

Standard designation according to EN 60079-0

Explosion group II C gases, low ignition energy such as hydrogen
 III C conductive dusts

Equipment Protection Level:

Ga (gases) for category 1
 Da (dust) for category 1

Standard designation according to standard series EN 60079 for electrical devices
 ia: related equipment according to ignition protection "i" intrinsically safe
 according to EN 60079-11

Standard designation

Category according to ATEX directive 2014/34/EU

G: gas explosion protection; D: dust explosion protection

Related equipment for intrinsic safety according to EN 60079-11 for category 1

Applications for ignition protection type intrinsic safety "ia"

Guidelines designation for device group II (non-firedamp endangered mine workings)

Designation explosionproof according to ATEX directive 2014/34/EU

Explanation

6.3 Meaning of the X character in the type examination certificate

The particular conditions for which the X follows the test report numbers are as follows:

- Switching operations may only be performed on the intrinsically safe electrical circuits when the JUMO exTHERM-DR, including all supply lines, is de-energized.
 - Voltage may only be applied to the JUMO exTHERM-DR, including all its supply lines, if the protective cap of the intrinsically safe electrical circuits has been fitted correctly
- ⇒ Chapter 4.2 "Removing the protective cap"
- For the JUMO probes in the ATEX test report, based on JUMO data sheet 901006 and 902006, a safe isolation between the sensor and fitting does not exist. As a result, for the safety evaluation, the sensor connections are to be considered grounded according to ATEX. This means that the user must ensure that during connection of the intrinsically safe electrical circuit through integration in the local potential (e.g. potential equalization or FB), the intrinsic safety of the JUMO exTHERM-DR is not reversed.
 - The probe connection heads of the probes under consideration do not fulfill the material composition requirements from EN 60079-0 for EPL Ga. Corresponding impact protection must therefore be ensured on site for use in EPL Ga.
- ⇒ Chapter 10.12 "Note about probes in Chapter 10.13 up to Chapter 10.15"

6.4 Associated, intrinsically safe electrical apparatus according to EN 60079-11

6.4.1 Function of intrinsic safety

The ignition protection type intrinsic safety "i" makes use of the fact that a certain energy is required in order to ignite a potentially explosive atmosphere. This is dependent upon the composition of the potentially explosive atmosphere.

An electrical circuit is intrinsically safe if it prevents this energy level from being exceeded, thus preventing an ignition either through switching sparks or a thermal effect, under certain test conditions and taking into consideration certain safety margins.

6.4.1.1 Definitions of intrinsic safety

An intrinsically safe electrical circuit is a circuit in which neither a spark nor a thermal effect occurring under the conditions specified in EN 60079-11, which include uninterrupted operation and defined fault conditions, may cause the ignition of a certain potentially explosive atmosphere.

The energy of the electrical circuit is limited such that it cannot cause an ignition. This applies to both spark formation and thermal effects. The test conditions with specific potentially explosive atmospheres are specified. The tests comprise uninterrupted operation and defined fault conditions.

6.4.1.2 Electrical apparatus:

Electrical apparatus is the collective term for electrical components and electrical circuits or parts of electrical circuits generally found together within a single housing.

6.4.1.3 Intrinsically safe electrical apparatus:

Electrical apparatus in which all electrical circuits are intrinsically safe.

6.4.1.4 Associated electrical apparatus:

Electrical apparatus in which not all electrical circuits are intrinsically safe. In terms of construction, the non-intrinsically safe electrical circuits cannot have an effect on the intrinsically safe electrical circuits.

The associated apparatus is identified through brackets: e.g. II (1) G [Ex ia] II C. Associated electrical apparatus can be used in potentially explosive areas provided it has the corresponding protection (ignition protection type according to EN 60079-0). In the event of insufficient protection, it must be used outside of the potentially explosive area.

Example:

The JUMO exTHERM-DR is not in the potentially explosive area, however it is connected to a thermocouple in the potentially explosive area. Only the input circuit of the JUMO exTHERM-DR is intrinsically safe.

The screw terminals marked in blue and the connected lines are protected with a protective cap.

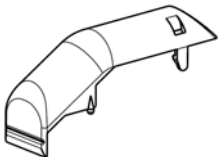
Figure 1: Protective cap

⇒ Chapter 4.2 "Removing the protective cap"

6.4.2 Probe arrangement in the Ex-area

The JUMO exTHERM-DR has the following maximum output data at the intrinsically safe inputs:

$U_o = 6.0 \text{ V}$; $I_o = 41.2 \text{ mA}$; $P_o = 61.8 \text{ mW}$; $C_o = 36.3 \text{ }\mu\text{F}$; $L_o = 20 \text{ mH}$

Example Pt100 with protection tube constant 80 K/W : temperature increase of $80 \text{ K/W} \times 61.8 \text{ mW} = 4.9 \text{ K}$.

If a separate temperature increase for dust is specified in the technical data sheet from JUMO, this means that the protection fitting is completely covered in dust.

Figure 2:

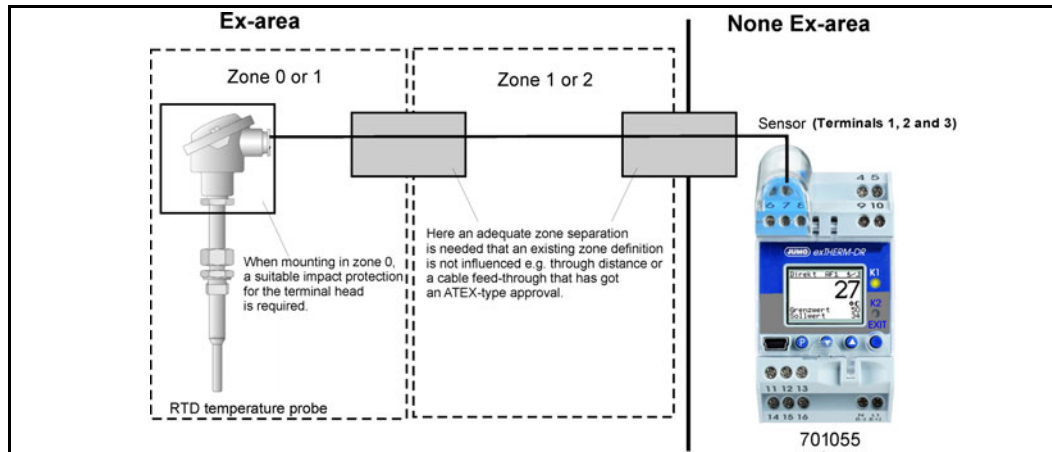

- ☝ The sensor technology specified in Chapter 10.13 Chapter 10.14 and Chapter 10.15 does not have zone separation.
- ⇒ Please also see the notes in Chapter 10.11. The type of zone separation as well as the cable selection must be implemented or selected in such a way that the defined zone classifications and their requirements continue to be in place.

Use of a probe with EPL "Gb" with a separation element (DIN EN 60079-26). The figure shows a probe with active zone separation in accordance with DIN EN 60079-26. The terminal head must not be mounted in zone 0!
However, use in zone 0 is permitted below the separation element. The same requirements as in figure 7 apply for the zone classification.

Figure 3:

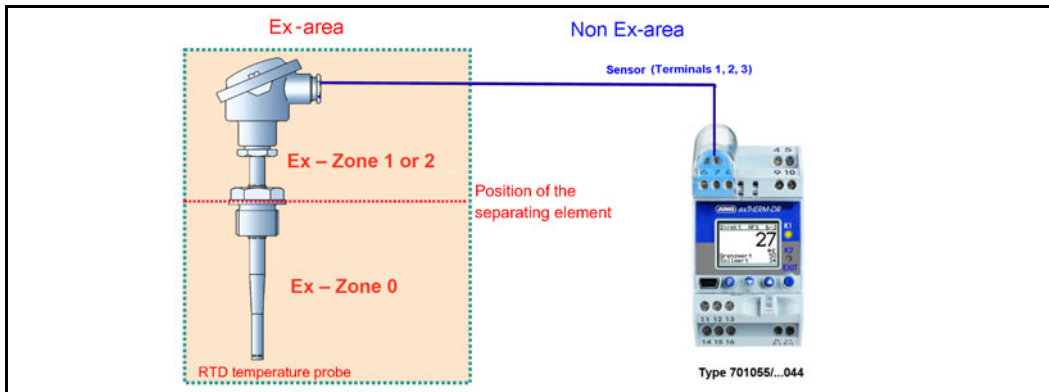

6.4.3 Explanation of probe temperature classes

The listed probes can be used in the temperature classes T1 to T6.

Table 1: Temperature classes

Temperature class	Maximum surface temperature of the apparatus ¹	Ignition temperature of the combustible materials
T1	450 °C	> 450 °C
T2	300 °C	>300 < 450 °C
T3	200 °C	>200 < 300 °C
T4	135 °C	>135 < 200 °C
T5	100 °C	>100 < 135 °C
T6	85 °C	>85 < 100 °C

Temperature classes

In EN 60079-0:2009, point 26.5.1.3, type-tested devices of group II (explosive gas atmospheres excluding mines susceptible to firedamp) require a safety margin for the highest measured surface temperature – 10 K for T1 and T2, and 5 K for T3, T4, T5 and T6.

In RTD temperature probes, a measuring current flows through the sensor element thus heating it up. In the event of a fault in the JUMO exTHERM-DR, a maximum power of 61.8 mW can also be introduced in the probe through the sensor electrical circuit. This also affects the thermocouple probes.

The maximum temperature rise was calculated through measurements.

The following values represent the worst-case scenario and apply to all probes:

The maximum temperature rise of Pt100 probes is **7.5°K**.

The maximum temperature rise of thermocouple probes is **0.9°K**.

1. Furthermore, the following safety margins must be adhered to:

Category 1: According to EN 1127-1:2011, point 6.4.2 (hot surfaces), the temperatures of all surfaces of devices...for use in zone 0...which may come into contact with a potentially explosive atmosphere...must not exceed 80 % of the ignition temperature.

The result is temperature class minus 20 %.

As described above, 10 °C must be subtracted in temperature classes T1 and T2 and 5 °C in temperature classes T3 to T6.

Example:

A thermocouple is to be used in the temperature class T4 (maximum temperature 135 °C, limit is to be reduced by 5 K for safety);

T_S Maximum admissible temperature at the probe head

$$T_S = 130 \text{ °C} - 0.9 \text{ °C}$$

$$T_S = \mathbf{129.1 \text{ °C}}$$

The maximum temperature (measuring or medium temperature) at the probe head must therefore not exceed a value of 129.1 °C.

The following table provides a summary of the calculations for all temperature classes:

Table 2:

	Medium and ambient temperature for applications that require category 2 devices		Medium and ambient temperature for applications that require category 1 devices	
	Sensor with PT100	Sensor with thermocouple	Sensor with PT100	Sensor with thermocouple
T1	439.1 °C	432.5 °C	349.1 °C	342.5 °C
T2	289.1 °C	282.5 °C	229.1 °C	222.5 °C
T3	194.1 °C	187.5 °C	154.1 °C	147.5 °C
T4	129.1 °C	122.5 °C	102.1 °C	95.5 °C
T5	94.1 °C	87.5 °C	74.1 °C	67.5 °C
T6	79.1 °C	72.5 °C	62.1 °C	55.5 °C

7 ATEX ignition protection type "e" and "t"

The increased safety classification "e" denotes the ignition protection type applied for an electrical device in which additional measures have been taken, in order to prevent, with an increased degree of safety, the possibility of impermissibly high temperatures and the generation of arcs in normal operation or under defined unusual conditions.

The stipulations and requirements for use specified in this document must be taken into consideration. All specifications below with regard to probes or sensor technology relate to the probes listed in Chapter 10.13 to Chapter 10.15. If other probes are used, their suitability must first be tested.



Important information:

Thermocouples should be evaluated with at least the requirements of EN 60584 or DIN 43710. RTD temperature probes should be evaluated with at least the requirements of EN 60751. Parameter values such as response rate, temperature stability, age drift, self-heating behavior, failure rates, fault models, etc. should likewise be taken into account.

7.1 Intended use

The JUMO exTHERM-DR 701055 is associated apparatus that may only be used outside the Ex-zone. Another use or one that goes beyond the specified use - with respect to use in potentially explosive areas - is considered as not being in accordance with the intended use. Consideration only in accordance with ATEX as an [Ex eb, tb] device and not in accordance with IECEx.

7.2 Ex e identification marking in accordance with EN 60079-7:

The nameplate is glued laterally to the device.



II (2) G [Ex eb Gb] IIC

II (2) D [Ex tb Db] IIIC

	II	(2)	G	[Ex eb Gb] IIC
	II	(2)	D	[Ex tb Db] IIIC
<div style="border: 1px solid black; padding: 5px; margin: 5px;"> Standard designation according to EN 60079-0 Explosion group II C gases, low ignition energy such as hydrogen III C conductive dusts </div>				
<div style="border: 1px solid black; padding: 5px; margin: 5px;"> Equipment Protection Level: Gb: for use in Zone 1 oder 2 for gases Db: for use in Zone 21 oder 22 for dust </div>				
<div style="border: 1px solid black; padding: 5px; margin: 5px;"> Standard designation according to EN 60079 for electrical devices ignition protection „eb“ increased safety according to EN 60079-7 ignition protection „tb“ dust explosion protection with housing accord. to EN 60079-31 </div>				
Standard designation				
<div style="border: 1px solid black; padding: 5px; margin: 5px;"> Category according to ATEX directive 2014/34/EU G: gas explosion protection; D: dust explosion protection </div>				
<div style="border: 1px solid black; padding: 5px; margin: 5px;"> Increased safety „e“ according to EN 60079-7 for category 2 </div>				
<div style="border: 1px solid black; padding: 5px; margin: 5px;"> Guidelines designation for device group II (non-firedamp endangered mine workings) </div>				
<div style="border: 1px solid black; padding: 5px; margin: 5px;"> Designation explosionproof according to ATEX directive 2014/34/EU </div>				

Explanation

7.2.1 Probe arrangement in the Ex-area

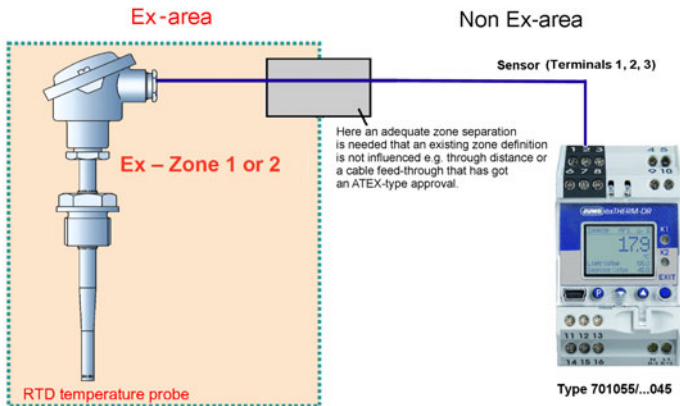

8 IECEX

8.1 Intended use

The JUMO exTHERM-DR 701055 is associated apparatus that may only be used outside the Ex-zone.
Another use or one that goes beyond the specified use ? with respect to use in potentially explosive areas ? is considered as not being in accordance with the intended use.

8.2 IECEX identification marking in accordance with IEC standards:

The nameplate is glued laterally to the device.



- [Ex ia Ga] IIC Associated apparatus which is set up outside the gas atmosphere but the intrinsically safe electrical circuit "ia" (protection through double protective measures) leads into zone 0.
- [Ex ia Da] IIIC Associated apparatus which is set up outside the dust atmosphere but the intrinsically safe electrical circuit "ia" (protection through double protective measures) leads into zone 20.

Explanation

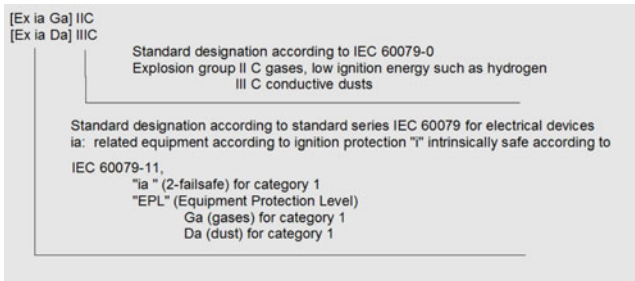

8.3 IECEx identification marking ignition protection type "e" and "t"

The nameplate is glued laterally to the device.



- [Ex eb Gb] IIC Associated equipment, which is installed outside the gas atmosphere but the circuit (protection by 1 protective measure) leads into zone 1.
- [Ex tb Db] IIIC Associated equipment, which is installed outside the dust atmosphere but the circuit (protection by 1-protection measures) leads into zone 21.

Standard designation according to EN 60079-0
Explosion group II C gases, low ignition energy such as hydrogen
III C conductive dusts.

Equipment Protection Level:
Gb: for use in zone 1 or 2 for gases
Db: (dust) for category 1, zone 21 for dust

Standard designation series to EN 60079-7 protection due to increased safety „e“
and standard designation EN 60079-1 device protection due to flameproof enclosure „d“
„e“ increased safety for category 2, „b“ zone 1 or 2 for gases
Standard designation series EN 60079-31 Equipment dust explosion protection by housing „t“
„t“ dust explosion protection by housing „t“, „b“ zone 21 for dust

Erklärung

8.4 Excerpt of important device data

Contents	Description	Further information
Name of the manufacturer	JUMO GmbH & Co. KG	⇒ See back of this operating manual
Address	Moritz-Juchheim-Straße 1 36039 Fulda Germany	
Description of the test piece Device type	JUMO exTHERM-DR 701055	⇒ Chapter 2 "Identifying the device version"
Ex identification marking	[Ex ia Ga] IIC [Ex ia Da] IIIC [Ex eb Gb] IIC [Ex tb Db] IIIC	⇒ Chapter 8.2 "IECEx identification marking in accordance with IEC standards:" ⇒ Chapter 8.3 "IECEx identification marking ignition protection type "e" and "t"
Certificate number	IECEx TUN 16.0022X	⇒ Chapter 16.2 "IECEx TÜV Nord"
Certificate number	IECEx SEV 22.0017X	⇒ Chapter 16.3 "IECEx Eurofins"
Protection type	Min IP20	⇒ Chapter 10.10 "Housing"
Admissible ambient temperature range (°C)	0 °C to +55 °C	⇒ Chapter 10.9 "Environmental influences"

Contents	Description	Further information
Special conditions for use of the device	<ol style="list-style-type: none"><li data-bbox="430 153 965 239">1. Intrinsically safe electrical circuits may only be connected when the JUMO exTHERM-DR is de-energized, including all supply lines.<li data-bbox="430 241 965 363">2. Before the JUMO exTHERM-DR, including all supply lines, is switched on, the protective cap for the intrinsically safe electrical circuits must be put back on correctly again.<li data-bbox="430 365 965 674">3. The JUMO temperature probes specified in the technical data from the data sheets 901006 and 902006, do not have any safe isolation to the fitting. For the safety evaluation, the connections are considered as grounded. This means that the plant operator must ensure that, during connection of the intrinsically safe electrical circuits, the local ground potential (e.g. potential equalization or FB) is present and the intrinsic safety of the JUMO exTHERM-DR is not negated by this. ⇒ Chapter 10.13 "Probes for the operating medium air"<li data-bbox="430 749 965 924">4. The temperature probe terminal heads do not meet the material composition requirements of IEC 60079-0:2011 which are required for category 1 applications. The device must be installed so that the danger of sparks from outside or through friction can be excluded.	⇒ Chapter 4.2 "Removing the protective cap" and Chapter 4.3 "Connection diagram"

9 Configuration level

9.1 Navigation principle

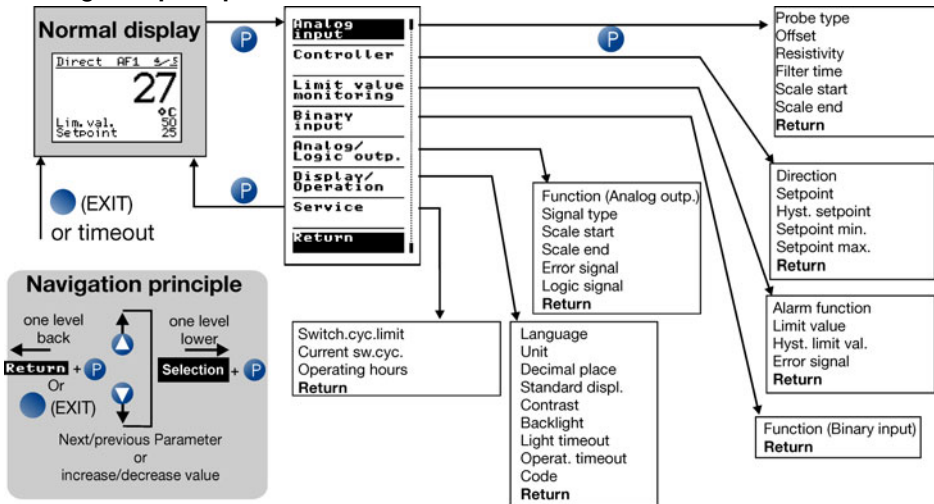

All the parameters are freely accessible ex works, but they can be locked via the setup program.

⇒ Chapter 11.3 "Forgotten the code?"

Parameters of the configuration level which are not required are automatically hidden depending on the setting.

9.2 Analog input

9.2.1 Sensor type for analog input	Comment	Limits for underrange/ overrange
Pt100 three-wire	in three-wire circuit IEC 60751:2008	-205 °C / +855 °C
Pt1000 three-wire	in three-wire circuit IEC 60751:2008	-205 °C / +855 °C
Pt100 two-wire	in two-wire circuit IEC 60751:2008	-205 °C / +855 °C
Pt1000 two-wire	in two-wire circuit IEC 60751:2008	-205 °C / +855 °C
W3Re-W25Re "D"	Thermocouple ASTM E1751M-09 (up to 2315 °C): 2009	-5 to +2500°C
W5Re-W26Re "C"	Thermocouple ASTM E230M-11: 2011	-5 to +2320°C
Cu-CuNi "T"	Thermocouple DIN EN 60584-1: 1996-10	-205 to +405°C
Fe-CuNi "J"	Thermocouple DIN EN 60584-1: 1996-10	-205 to +1205°C
Cu-CuNi "U"	Thermocouple DIN 43710: 1985-12	-205 to +605°C
Fe-CuNi "L"	Thermocouple DIN 43710: 1985-12	-205 to +905°C
NiCr-Ni "K"	Thermocouple DIN EN 60584-1: 1996-10	-205 to +1377°C
Pt10Rh-Pt "S"	Thermocouple DIN EN 60584-1: 1996-10	-55 to +1773°C
Pt13Rh-Pt "R"	Thermocouple DIN EN 60584-1: 1996-10	-55 to +1773°C
Pt30Rh-Pt6Rh "B"	Thermocouple DIN EN 60584-1: 1996-10	295 to 1825°C
NiCrSi-NiSi "N"	Thermocouple DIN EN 60584-1: 1996-10	-105 to +1305°C
4 to 20 mA	Standard signal	3.6 to 21 mA

■ Default setting

Parameters	Comment	Value range (default setting in bold)
9.2.2 Offset	Using Offset1, a measured value at the analog input can be corrected by the value entered over the entire measuring range.	-999.9 to 0.0 to 999.9
9.2.3 Lead wire resistance	Lead wire resistance analog input 1 in two-wire circuit This value is used to compensate the resistance of the probe line and depends on the line length. Enter the ohmic resistance of the probe line here to achieve the best possible temperature measurement.	0.0 to 30.0 ohm
9.2.4 Filter time	Time constant of the digital input filter 2nd order for analog input 1 If the input signal changes suddenly, approx. 26 % of the change is recorded following a period that corresponds to the filter time constant dF ($2 \times dF$: approx. 59 %; $5 \times dF$: approx. 96 %). Value 0 means: filter switched off If the filter time is long: - Interfering signals are better absorbed - Measured value display responds more slowly to changes	0.0 to 0.6 to 100 sec
9.2.5 Scaling start	Here, the user selects which value (i.e. pressure) should be displayed at 4 mA.	-9999 to 0 to 9999
9.2.6 Scaling end	Here, the user selects which value (i.e. pressure) should be displayed at 20 mA.	-9999 to 100 to 9999

9.3 Controller

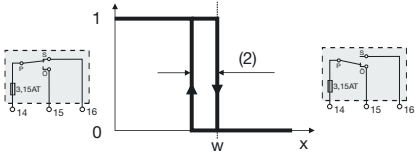
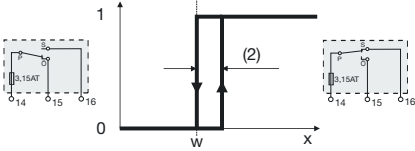
Parameters	Comment	Value range (default setting in bold)
9.3.1 Control direction	<p>Inverse: heating function If the measured value is below the setpoint value + hysteresis, relay output controller K1 switches on. If the measured value exceeds the setpoint value, the relay switches off.</p>  <p>(2) Hysteresis w Setpoint value</p>	Inverse, direct
	<p>Direct: cooling function If the measured value exceeds the setpoint value + hysteresis, relay output controller K1 switches on. If the measured value is below the setpoint value, the relay switches off.</p>  <p>(2) Hysteresis w Setpoint value</p>	

Parameters	Comment	Value range (default setting in bold)
9.3.2 Setpoint value	The setpoint value determines the switching point (1) in the figures above.	Setpoint value max. to 0 to setpoint value min.
9.3.3 Hysteresis setpoint value	The hysteresis determines the gap between switch-off and switch-on threshold (2) in the figures above.	0 to 2 to 100
9.3.4 Setpoint value min.	This value is the lower input limit for the setpoint value.	-9999 to setpoint value
9.3.5 Setpoint value max.	This value is the upper input limit for the setpoint value.	Setpoint value to 9999

9.4 Limit value monitoring

The relay output limit value K2 can be set for monitoring of the following functions.

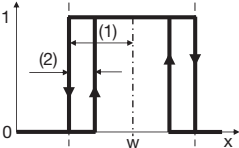
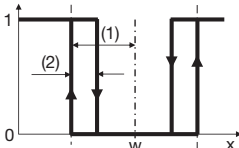
Parameters	Comment	Value range (default setting in bold)
9.4.1 Alarm function	<p>AF1: ON circuit in the window around the setpoint value</p>  <p>(1) Limit value is gap compared to setpoint value w (2) Hysteresis</p> <p>AF2: OFF circuit in the window inversely around the setpoint value</p>  <p>(1) Limit value is gap compared to setpoint value w (2) Hysteresis</p>	<p>No function, AF1 to AF8</p>

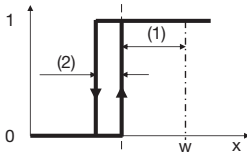
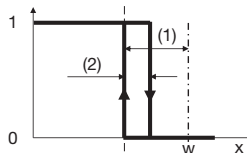
Parameters	Comment	Value range (default setting in bold)
	<p>AF3: ON circuit before reaching the setpoint value</p>  <p>(1) Limit value is gap compared to setpoint value w (2) Hysteresis</p>	
	<p>AF4: OFF circuit before reaching the setpoint value</p>  <p>(1) Limit value is gap compared to setpoint value w (2) Hysteresis</p>	

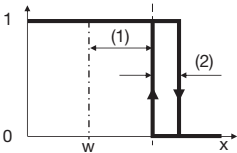
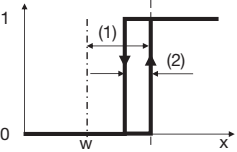
Parameters	Comment	Value range (default setting in bold)
	<p>AF5: OFF circuit after exceeding the setpoint value</p>  <p>(1) Limit value is gap compared to setpoint value w (2) Hysteresis</p>	
	<p>AF6: ON circuit after exceeding the setpoint value</p>  <p>(1) Limit value is gap compared to setpoint value w (2) Hysteresis</p>	

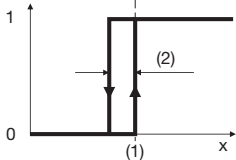
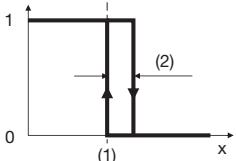
Parameters	Comment	Value range (default setting in bold)
	<p>AF7: ON circuit from a fixed limit value</p>  <p>(1) Limit value (2) Hysteresis</p>	
	<p>AF8: OFF circuit from a fixed limit value</p>  <p>(1) Limit value (2) Hysteresis</p>	
<p>9.4.2 Limit value</p>	<p>As shown in the figures, the limit value is:</p> <ul style="list-style-type: none"> - for the functions AF1 to AF6, the gap compared to the set-point value - for the functions AF7 and AF8, it is a fixed switching point 	<p>-9999 to 0 to 9999</p>

Parameters	Comment	Value range (default setting in bold)
9.4.3 Hysteresis limit value	The hysteresis determines the gap between switch-on and switch-off threshold (2) in the figures AF1 to AF8.	0 to 2 to 9999
9.4.4 Error signal	Active means: the relay output picks up in the event of a fault. Inactive means: the relay output drops out in the event of a fault. ⇒ Chapter 13 "Error messages"	Active , inactive

9.5 Digital input

Parameter	Comment	Value range (default setting in bold)
9.5.1 Function	This sets the function that should be controlled by the binary input.	
	The binary input does not have a function	No function
	Protection against unauthorized key operation	Keyboard lock
	Configuration level is locked.	Level inhibit

9.6 Analog/logic output

Parameters	Comment	Value range (default setting in bold)
9.6.1 Function	This setting specifies the signal that should be output at the analog output.	Measured value, Setpoint value, Logic output
	Measured value: The value measured at the analog input is output.	
	Setpoint value: The setpoint value is output.	
	Logic output: With this setting, the switching status of the relay output controller K1 or limit value K2 is also output as a binary signal 0/10V. The output now no longer functions as an analog output. This is set in Chapter 9.6.6. The relay outputs retain their switching function.	
9.6.2 Signal type	4 to 20 mA	4 to 20 mA, 0 to 20 mA 2 to 10 V 0 to 10 V
	0 to 20 mA	
	2 to 10 V	
	0 to 10 V	
9.6.3 Scaling start	⇒ Figure in Chapter 9.6.7	-9999 to -200 to 9999
9.6.4 Scaling end	⇒ Figure in Chapter 9.6.7	-9999 to 800 to 9999

Parameters	Comment	Value range (default setting in bold)
9.6.5 Error signal	If, for the measured value 1, the value is exceeded, not reached, or a diagnostic error occurs, the current or voltage value set on the analog output is output as a so-called error signal.	
	For signal type 4 to 20 mA	3.4 or 21.2 mA
	For signal type 0 to 20 mA	0 or 21.2 mA
	For signal type 2 to 10 V	1.7 or 10.4 V
	For signal type 0 to 10 V	0 or 10.4 V
9.6.6 Logic output	This setting only appears if "Logic output" is set under Chapter 9.6.1. This sets whether the switching status of the controller (K1) or switching status of the limit value (K2) is output.	Controller (K1) Limit value (K2)

9.6.7 Behavior when leaving the scaling range

The standard signal range of the analog output is limited as follows according to the recommendation of Namur NE 43:

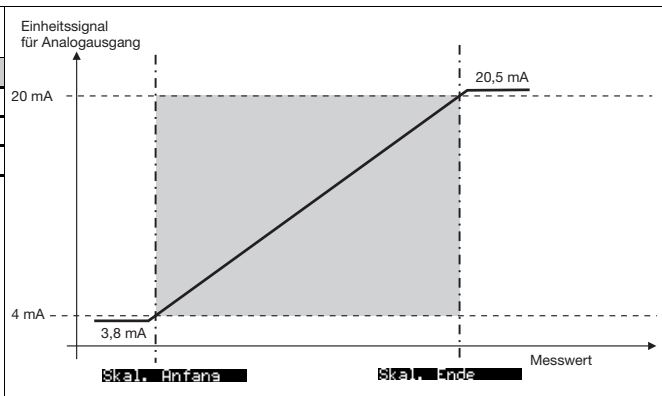

Signal type	Lower limit	Upper limit
0: 4 to 20 mA	3.8 mA	20.5 mA
1: 0 to 20 mA	0 mA	20.5 mA
2: 2 to 10 V	1.8 V	10.2 V
3: 0 to 10 V	0 V	10.2 V

■ Default setting



9.7 Display/operation

Parameters	Comment	Value range (default setting in bold)
9.7.1 National language	German	German , English, French
	English	
	French	
9.7.2 Unit  If the unit is changed to °F, the measured value is converted. All other values referring to the measured value (e.g. limit value) remain unchanged.	A unit for the measured value can be assigned here.	°C, °F, %, text
	°C	
	°F	
	%	
	Text: Via the setup program, 2 characters can be entered here for another unit, e.g. Pa (Pascal).	
9.7.3 Decimal place	No decimal place	No decimal place , One decimal place
	One decimal place	
9.7.4 Normal display	This sets the view that appears after the voltage supply is switched on. ⇒ Chapter "Operating overview"	Measured value , Limit value, Setpoint value, I/O info
9.7.5 Contrast	Screen contrast: Difference in brightness between black and white pixels	0 to 5 to 10

Parameters	Comment	Value range (default setting in bold)
9.7.6 Lighting	Here, the background lighting of the display is set.	Off, On , During operation
	Off: Always switched off	
	On: Always switched on	
	During operation: The background lighting is only switched on when the keys are operated and it lights up until the time for the timeout light has expired.	
9.7.7 Timeout light	Here, a waiting period for the switch-off of the background lighting is set.	0 to 30 to 100 sec
9.7.8 Timeout operation	Here, the waiting period is set for the return from the configuration to normal display.	0 to 30 to 100 sec
9.7.9 Code	<p>To prevent unintentional changes to configuration data, a code for locking the configuration level can be set here.</p> <p>0 means: code request switched off</p> <p> If the code is forgotten, a new code can be transferred to the device via the setup program.</p> <p> Chapter 11.3 "Forgotten the code?"</p>	0 to 9999

9.8 Service

Parameters	Comment	Value range (default setting in bold)
<p>9.8.1 Limit switching operation</p> 	<p>Limit value for relay output controller K1</p> <p>Here, the limit value for the admissible relay switching operations is set.</p> <p>If the counter value for Current switching operations is greater than this value, the display values flash and the relay output controller K1 drops out.</p> <p>If the ● (EXIT) key is pressed, the corresponding error message appears.</p> <p>The relay output limit value K2 and the analog output react as configured under "Error signal" in Chapter 9.4.4 and Chapter 9.6.5.</p> <p>If "0" is set the function is inactive.</p>	<p>0 to 99999</p>
<p>9.8.2 Current switching operations</p>	<p>Switching operation counter for relay output controller K1</p> <p>Here, the switching operations for the relay are only counted if the top limit value for relay switching operations is not set to "0" and is thus inactive.</p> <p>The value can then be adjusted as required and therefore adapted accordingly to the plant.</p> <p>The switching operation counter remains at 99999.</p>	<p>0 to 99999</p>

Parameters	Comment	Value range (default setting in bold)
9.8.3 Operating hours	Operating hours counter The counter adds up the operating hours during which the device was connected to the voltage supply. The value cannot be changed and can be used as a measure of how long the device was actually in operation after leaving the factory.	0 to 99999

10 Technical data

10.1 Analog inputs

RTD temperature probes

Designation	Measuring range	Accuracy Two/three-wire circuit ¹	Ambient temperature influence
Pt100 IEC 60751:2008	-200 to +850 °C	0.5 % / 0.1 %	50 ppm/K
Pt1000 IEC 60751:2008	-200 to +850 °C	0.5 % / 0.1 %	50 ppm/K
Connection type	Maximum line resistance in two-wire circuit: 15 Ω; three-wire circuit: 30 Ω		
Sampling rate	210 ms		
Error tolerance time	≤ 5 s time taken into account for all diagnostic tests		
Input filter	Digital filter, 2nd order; filter constant can be set from 0 to 100 s		
Special features	Individual probe Pt100 two-wire, display can also be programmed in °F		

Thermocouples

Designation	Measuring range	Accuracy ¹	Ambient temperature influence
Fe-CuNi "L" DIN 43710: 1985-12	-200 to +900 °C	0.4 %	100 ppm/K
Fe-CuNi "J" DIN EN 60584-1:1996-10	-200 to +1200 °C	0.4 %	100 ppm/K

Cu-CuNi "U" DIN 43710:1985-12	-200 to +600 °C	0.4 %	100 ppm/K
Cu-CuNi "T" DIN EN 60584-1:1996-10	-200 to +400 °C	0.4 %	100 ppm/K
NiCr-Ni "K" DIN EN 60584-1:1996-10	-200 to +1372 °C	0.4 %	100 ppm/K
Pt10Rh-Pt "S" DIN EN 60584-1:1996-10	-50 to +1768 °C	0.4 %	100 ppm/K
Pt13Rh-Pt "R" DIN EN 60584-1:1996-10	-50 to +1768 °C	0.4 %	100 ppm/K
Pt30Rh-Pt6Rh "B" DIN EN 60584-1:1996-10	0 to 1820 °C	0.4 % ²	100 ppm/K
NiCrSi-NiSi "N" DIN EN 60584-1:1996-10	-100 to 1300 °C	0.4 % ²	100 ppm/K
W3Re-W25Re "D" ASTM E1751M-09 (up to 2315 °C): 2009	0 to 2495 °C	0.4 %	100 ppm/K
W5Re-W26Re "C" ASTM E230M-11: 2011	0 to 2315 °C	0.4 %	100 ppm/K
Cold junction	Pt100 internal		
Cold junction accuracy	± 1 K		
Sampling rate	210 ms		
Input filter	Digital filter, 2nd order; filter constant can be set from 0 to 100 s		

1. The accuracy refers to the maximum measuring range.
2. The accuracy specifications are only guaranteed as of 300 °C.

Direct current

Measuring range	Accuracy	Ambient temperature influence
4 to 20 mA, voltage drop < 2 V	0.2 %	150 ppm/K
Scaling	Can be freely programmed within the limits	
Sampling rate	210 ms	
Input filter	Digital filter, 2nd order; filter constant can be set from 0 to 100 s	
Special features	Individual probe 4 to 20 mA	

10.2 Analog output

	Signal type	Accuracy	Residual ripple	Load influence	Temperature influence	Load resistance
Current	4 to 20 mA	≤ 0.5 %	± 0.5 % at 300 Ω	± 0.05 mA / 100 Ω	150 ppm/K	≤ 500 Ω
	0 to 20 mA					
Voltage	2 to 10 V	≤ 0.5 %	± 0.5 %	± 15 mV	150 ppm/K	≥ 500 Ω
	0 to 10 V					
Logic output	Binary signal 0/10 V	≤ 0.5 %	± 0.5 %	± 15 mV	150 ppm/K	≥ 500 Ω

10.3 Digital input

Connection	Function
1 potential-free contact	Keyboard lock, level inhibit configurable

10.4 Relay outputs

Relay output controller K1	Relay (changeover contact) Contact protection circuit: fuse cut-out 3.15 AT, installed in the N/O contact arm 30000 switching operations at a switching capacity of AC 230 V, 3 A, 50 Hz (resistive load) or up to DC 30 V, 3 A. Minimum current: DC 12 V, 100 mA.
Relay output limit value K2	Relay (changeover contact) without contact protection 30000 switching operations at a switching capacity of AC 250 V, 3 A, 50 Hz (resistive load) or up to DC 30 V, 3 A. Minimum current: DC 12 V / 100 mA..

10.5 Measuring circuit monitoring

	RTD temperature probes	Thermocouples	Current 4 to 20 mA
Overrange and underrange	is detected in the display, ">>>>" flashes for overrange and "<<<<" for underrange.		
Probe/cable break	is detected ">>>>" flashes in the display; relay output controller K1 is inactive		">>>>" flashes in the display; relay output controller K1 is inactive
Probe short circuit	is detected "<<<<" flashes in the display; relay output controller K1 is inactive	is not detected	"<<<<" flashes in the display; relay output controller K1 is inactive

10.6 Voltage supply

Voltage supply	AC/DC 20 to 30 V, 48 to 63 Hz AC 110 to 240 V, +10/-15 %, 48 to 63 Hz
Power consumption	12 VA
Power loss	< 12 W

10.7 Test voltages according to EN 60730, Part 1

Input and output against voltage supply	
- With a voltage supply AC 110 to 240 V +10 % /-15 %	3.7 kV/50 Hz
- With a voltage supply AC/DC 20 to 30 V, 48 to 63 Hz	3.7 kV / 50 Hz

10.8 Electrical safety

	Clearances / creepage distances
Mains voltage to electronic components and probes	$\geq 6 \text{ mm} / \geq 8 \text{ mm}$
Mains voltage to relays	$\geq 6 \text{ mm} / \geq 8 \text{ mm}$
Relays to electronic components and probes	$\geq 6 \text{ mm} / \geq 8 \text{ mm}$
Electrical safety	According to DIN EN 60730-1, overvoltage category III, pollution degree 2
Protection rating I	With internal isolation from SELV electrical circuits

10.9 Environmental influences

Ambient temperature range	0 to +55 °C
Storage temperature range	-30 to +70 °C
Site altitude	maximum 2000 m above MSL
Temperature influence	$\leq \pm 0.005 \text{ \%} / \text{K dev. from } 23 \text{ }^\circ\text{C}^1$ for RTD temperature probes
	$\leq \pm 0.01 \text{ \%} / \text{K dev. from } 23 \text{ }^\circ\text{C}^1$ for thermocouple and current
Resistance to climatic conditions	85 % rel. humidity without condensation (3K3 with extended temperature range according to DIN EN 60721-3-3)

EMC	according DIN EN 60730-1: 2021
Interference emission	Class B -for industrial and domestic use-
Interference immunity	Industrial requirement

1. All specifications refer to the measuring range end value

10.10 Housing

Material	Polycarbonate
Flammability class	UL 94 V0
Electrical connection	On the front via screw terminals up to max. 2.5 mm ²
Mounting	On 35 mm DIN rail according to DIN EN 60715
Installation position	Vertical
Weight	Approx. 230 g
Protection type	IP 20 according to DIN EN 60529

10.11 Note about suitable probes

The probes in data sheet 902820, 902821 with JUMO declaration of manufacturer and other approved probes can be connected.

10.12 Note about probes in Chapter 10.13 up to Chapter 10.15

The following should be noted:

- A safe isolation between the sensor and fitting does not exist. As a result, the sensor connections are to be considered grounded for the safety evaluation.
- Among other things EN 60079-0 requires for the EPL Ga that the mass fraction of aluminum must be less than 10 % for the manufacturing of metallic housings. The terminal head of the probes used by JUMO contains more than 10 % aluminum.

The terminal head must therefore be secured by suitable impact protection for the use of EPL Ga (zone 0). The impact protection must securely prevent friction sparks, contact-breaking sparks, and impact sparks. Otherwise there is a risk of ignitable sparks.

No other precautions have to be taken when used in EPL Gb (zone 1).

10.12.1 Recommended tests for temperature probes

To ensure safe and reliable operation of the thermometers, the following service and maintenance work must be performed (also during commissioning):

The following tests are recommended at certain intervals:

- As indicated in the table below, the insulation resistance of the measuring circuit must be measured against the protection fitting (for thermocouples: only for the insulated measuring circuit; in the case of multiple measuring circuits, the insulation test must also be performed between the individual measuring circuits). The minimal insulation resistance at room temperature should be 100 M Ω at DC 100 V.
- Damage and corrosion and Signs of wear of thermometers – protection tubes
- Clear assignment of sensor and associated protection tube/immersion sleeve by checking the installation depth
- Corrosion and correct positioning of the contacts and terminals of cable connections
- Seals of terminal heads and cable entries
- Interruptions due to "knocking, shaking" on the thermometer/measuring insert

10.13 Probes for the operating medium air

Note: because of the response accuracy, **the use of thermowells** (immersion sleeves) **is not admissible.**

Type designation	Probe Type	Temperature range	xxx = Nom. length in mm	Process connection
RTD temperature probe data sheet 902006				
902006/65-228-1003-1-15-xxx-668/922	1 x Pt100	-170 ... +700°C	500, 710, 1000	movable compression clamp
902006/55-228-1003-1-15-xxx-254/922	1 x Pt100	-170 ... +700°C	500, 710, 1000	movable compr. clamp G1/2
902006/65-228-2003-1-15-xxx-668/922	2 x Pt100	-170 ... +700°C	500, 710, 1000	movable compression clamp
902006/55-228-2003-1-15-xxx-254/922	2 x Pt100	-170 ... +700°C	500, 710, 1000	movable compr. clamp G1/2
Thermocouples data sheet 901006				
901006/65-547-2043-15-xxx-668/922	2 x NiCr-Ni, Type „K“	-35 ... +800°C	500, 710, 1000	movable compression clamp
901006/65-546-2042-15-xxx-668/922	2 x Fe-CuNi, Type „L“	-35 ... +700°C	500, 710, 1000	
901006/66-550-2043-6-xxx-668/922	2 x NiCr-Ni, Type „K“	-35 ... +1000°C	250, 355, 500	
901006/66-880-1044-6-xxx-668/922	1 x PT10Rh-PT, Type „S“	0 ... 1300°C	250, 355, 500	movable compression clamp
901006/66-880-2044-6-xxx-668/922	2 x PT10Rh-PT, Type „S“	0 ... 1300°C	250, 355, 500	
901006/66-953-1046-6-xxx-668/922	1 x PT30Rh-PT6Rh, Type „B“	600 ... 1500°C	250, 355, 500	
901006/66-953-2046-6-xxx-668/922	2 x PT30Rh-PT6Rh, Type „B“	600 ... 1500°C	250, 355, 500	

10.14 Probes for water and oil

Note: because of the response accuracy, **the use of thermowells** (immersion sleeves) **is not admissible**.

Type designation	Probe type	Temperature range	Nom. length mm	Process connection
RTD temperature probe data sheet 902006				
902006/10-226-1003-1-9-250-104/922	1 x Pt100	-40 ... +480°C	250	G1/2 compression clamp
902006/10-226-2003-1-9-250-104/922	2 x Pt100		250	
902006/54-227-2003-1-15-710-254/922	2 x Pt100	-170 ... 550°C	65...670	movable G1/2 compression clamp
902006/54-227-1003-1-15-710-254/922	1 x Pt100		65...670	
902006/10-402-1003-1-9-100-104/922	1 x Pt100	-170 ... 400°C	100	G1/2 compression clamp
902006/10-402-2003-1-9-100-104/922	2 x Pt100		100	
902006/10-402-1003-1-9-150-104/922	1 x Pt100		150	
902006/10-402-2003-1-9-150-104/922	2 x Pt100		150	
902006/10-402-1003-1-9-200-104/922	1 x Pt100		200	
902006/10-402-2003-1-9-200-104/922	2 x Pt100		200	
Thermocouples data sheet 901006				
901006/54-544-2043-15-710-254/922	2 x NiCr-Ni, Type „K“	-35 ... 550°C	65...670	movable G1/2 compression clamp
901006/54-544-1043-15-710-254/922	1 x NiCr-Ni, Type „K“		65...670	
901006/54-544-2042-15-710-254/922	2 x FeCuNi, Type „L“		65...670	
901006/54-544-1042-15-710-254/922	1 x FeCuNi, Type „L“		65...670	

Note: Because of the response accuracy, only use thermowells (pockets) that are **included in the scope of delivery**

Type designation	Probe type	Temperature range	Nom. length mm	Process connection
RTD temperature probe data sheet 902006				
902006/53-505-2003-1-12-190-815/922	2 x Pt100	-40 ... +400 °C	190	weld-in sleeve
902006/53-505-1003-1-12-190-815/922	1 x Pt100	-40 ... +400 °C	190	
902006/53-507-2003-1-12-100-815/922	2 x Pt100 (im Schutzrohr untereinander angeordnet)	-40 ... +480 °C	100, 160, 190, 220	
902006/53-507-1003-1-12-100-815/922	1 x Pt100	-40 ... +480 °C	100, 160, 220	
902006/53-505-3003-1-12-100-815/922	3 x Pt100	-40 ... +400 °C	100, 160, 220	
902006/40-226-1003-1-12-220-815/922	1 x Pt100	-170 ... +480°C	100, 160, 220	
Thermocouples data sheet 901006				
901006/53-543-1042-12-220-815/922	1 x Fe-CuNi Type „L“	-35 ... 480°C	220	weld-in sleeve
901006/53-543-2042-12-220-815/922	2 x Fe-CuNi Type „L“		220	

10.15 Probes for air, water, and oil

Note: because of the response accuracy, **the use of thermowells** (immersion sleeves) **is not admissible**

Type designation	Probe type	Temperature range	Nom. length	Process connection
RTD temperature probe data sheet 902006				
902006/10-390-1003-1-8-250-104/922	1 x Pt100	max. 300°C	Nom. length: 250 mm	Screw-in thread G1/2
Thermocouples data sheet 901006				
901006/45-551-2043-2-EL-11-AL/922	2 x NiCr-Ni, Type „K“	max. 1150°C	50 < EL < 2000 1000 < AL < 20000	

11 Setup program

The program and the connecting cable are available as accessories and offer the following possibilities:

- Simple and convenient parameterization and archiving via PC
- Easy parameter duplication for identical types of devices

11.1 Minimum hardware and software requirements:

- PC Pentium III or higher
- 128 MB RAM, 16 MB free on hard disk
- CD-ROM drive
- Free USB interface, mouse connection
- Microsoft¹ Windows 2000/XP
- * Connect the device to the PC using the USB cable

11.2 Displaying the device software version

- * Simultaneously press the **P** and **▲** keys and hold down

This version is also recognized by the setup program and displayed under *Info* ⇒ *Information about setup*.

The software versions of the device and the setup program must be compatible as otherwise an error message will appear!

1. Microsoft is a registered trademark of Microsoft Corporation



11.3 Forgotten the code?

If you forget the code, it can be read out via the USB interface and the setup program.

* Use *Data transfer* \Rightarrow from device.

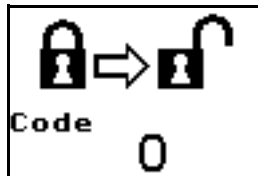

The read-out code now appears in the setup program.

It can be kept as it is or changed.

If "0" is set and transferred to the device, the code interrogation is deactivated and the configuration level is freely accessible.

11.4 Special function: thermocouple reverse polarity protection

If the polarity of a thermocouple is reversed, measured values are shown that do not reflect the real situation, for example, negative temperatures may be displayed instead of the expected positive temperatures.

This may lead to the set limit value never being reached. For this purpose, an additional limit value is defined at $-205\text{ }^{\circ}\text{C}$ by default, which triggers the relay output controller K1 if the value falls below this.

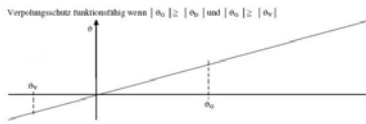

A suitable value must be selected here so that it is possible to detect potential reverse polarity.



Grenzwert einstellbar: θ_0 $-9999\text{ }^{\circ}\text{C}$ bis $+9999\text{ }^{\circ}\text{C}$ z.B. $-50\text{ }^{\circ}\text{C}$
Grenzwert Verpölgungsschutz einstellbar: θ_1 $-205\text{ }^{\circ}\text{C}$ bis $+200\text{ }^{\circ}\text{C}$ z.B. $100\text{ }^{\circ}\text{C}$
Grenzwert Differenzmessung einstellbar: θ_2 $0\text{ }^{\circ}\text{C}$ bis $100\text{ }^{\circ}\text{C}$
Im Falle der asymmetrischen Verpölgung der Sensorik, schaltet der STB die Anlage beim Erreichen des Differenzgrenzwertes die Anlage sicher ab.
Im Falle der symmetrischen Verpölgung wird dem STB fallende Temperatur auf den redundanten Kanälen signalisiert.
Wird der Verpölgungsgrenzwert erreicht, schaltet der STB sicher die Anlage ab.

12 Alarm messages

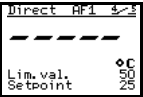
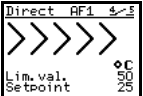
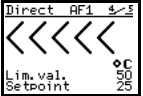
They can appear as follows:

Alarm display	Cause	Remedy
5 flashing horizontal lines: 	Measured value error No valid value can be displayed	<ul style="list-style-type: none"> * Check error messages on the device * Contact the JUMO Service department ⇨ For service addresses see back cover
	Measured value overrange The measured value is too high, is outside the measuring range or the probe is broken.	<ul style="list-style-type: none"> * Check the probe and connecting cable for damage or short-circuit. ⇨ Chapter 4.3 "Connection diagram" * Check that the correct probe is set and/or connected.
	Measured value underrange The measured value is too low, is outside the measuring range or a short-circuit occurred at the probe.	
5 flashing asterisks 	Display overflow Value cannot be displayed	<ul style="list-style-type: none"> * Check error messages on the device * Contact the JUMO Service department ⇨ For service addresses see back cover

13 Error messages

These error messages are displayed one below the other.

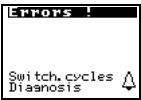
Error display (Err)	Origin	Cause/remedy
	Internal	The set limit value for relay switching cycles has been reached * Increase limit value of the relay switching cycles ⇒ Chapter 9.8.1 "Limit switching operation"
Terminal temp.	Internal	The internal Pt100 is defective ¹ , or the terminal temperature has fallen outside the admissible range (-10 to 80 °C). Acknowledgement is not possible until it is within the valid range again.
Reference volt. ¹	Internal	The reference voltage is outside the valid range. Acknowledgement is not possible until it is within the admissible range again.
Calibration const. ¹	Internal	A calibration constant is outside the valid range. Acknowledgement is not possible until it is within the admissible range again.
Configuration	Internal	Configuration data outside the value range. Acknowledgement is not possible until it is within the admissible range again.
Measured value	Internal	The measured value 1 is outside the valid range. Acknowledgement is not possible until it is within the admissible range again.

Error display (Err)	Origin	Cause/remedy
Measured value missing	Internal	When the error status "Measured value" is signaled by the channel, the diagnosis function tries to show the precise error on the basis of the read measured value.
Probe short-circ.	External	
Meas. overr.		
Meas. underr.		
Probe break		
Operating access ¹	Internal	The diagnosis function communicates with the exTHERM-DR. Acknowledgement is not possible until communication has finished.
Setup access	Internal	The setup program communicates with the exTHERM-DR. Acknowledgement is not possible until communication has finished.
CRC calibr. ¹	Internal	Checksum error of the EEPROM calibration data. Acknowledgement is not possible until it is within the admissible range again.
CRC config. ¹	Internal	Checksum error of the EEPROM configuration data. Acknowledgement is not possible until it is within the admissible range again.
Registry ¹	Internal	A registry error has occurred. Acknowledgement not possible until the error has been remedied.
RAM defective ¹	Internal	A RAM error has occurred. Acknowledgement not possible until the error has been remedied.
ROM defective ¹	Internal	A ROM error has occurred. Acknowledgement is not possible until it is within the admissible range again.
Program sequence ¹	Internal	A program sequence error has occurred. Acknowledgement not possible until the error has been remedied.

Error display (Err)	Origin	Cause/remedy
Watchdog ¹	Internal	A watchdog reset has occurred. Acknowledgement is possible.
Overvoltage ¹	Internal	The uncontrolled secondary voltage supply is too high. Acknowledgement is possible.
Frequency ¹	Internal	Error of the independent time base. Acknowledgement is possible
EEPROM defective ¹	Internal	Error during internal communication with the EEPROM. Acknowledgement is possible.
Stack ¹	Internal	Error in the memory area reserved for the stack. Acknowledgement is not possible until it is within the admissible range again.
AD converter ¹	Internal	Error during internal communication with the A/D converter. Acknowledgement is possible
Simulation ¹	Internal	Error during the measured value simulation. Acknowledgement is possible.
Zero point ¹	Internal	The zero point voltage of the A/D converter is too low. Acknowledgement is possible.

Error display (Err)	Origin	Cause/remedy
Diagnosis function		
FLASH defective ¹	Internal	An error was detected during the cyclic memory test of the ROM.
RAM defective ¹	Internal	An error was detected during the cyclic memory test of the RAM.
CRC config. ¹	Internal	An error was detected by the checksum test (CRC16) in the configuration of the diagnosis function.
CRC calib. ¹	Internal	An error was detected by the checksum test (CRC16) in the calibration data of the diagnosis function.
Configuration	Internal	The configuration contains invalid data.
SW version ¹	Internal	The software versions are invalid.
Editing	Internal	An error has occurred during editing.
V too low	Internal	The internal voltage supply value has fallen below the permitted range.
V too high	Internal	The permitted range of the internal voltage supply has been exceeded.
Int. communic. ¹	Internal	An error has occurred during internal communication.
Switching cycles	Internal	The configured limit of the switching cycles of relay output controller K1 has been exceeded. The error can be remedied by reducing the current counter or increasing the limit. (So that the switching cycles are not accidentally set to 0 in the event of further errors).
USB communic.	Internal	An error has occurred during USB communication.

- 1.) If the error cannot be acknowledged despite repeated switching off and on, the device must be repaired by JUMO.
 - * Return the device
 - ⇒ For service addresses see back cover

14 What to do, if ...

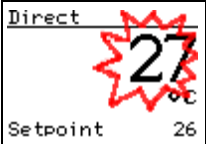
Description	Cause	Remedy
<p>The measured value flashes in the top display</p> 	<p>- The device has detected an error.</p>	<p>* In the normal display, press the EXIT key to see the error message. ⇒ Chapter 13 "Error messages"</p>
<p>Relay output controller K1 does not switch, meaning that the contact between terminal 14 and 16 is not closed although the LED lights up yellow.</p>	<p>- The integrated fuse cut-out is defective, caused by an excessive relay current.</p>	<p>* Use a continuity test device to measure terminal 14 and 16 of the relay when the LED K1 lights up yellow. * The device must be repaired by JUMO if no continuity can be measured. ⇒ For service addresses see back cover</p>
<p>... the display is dark</p>	<p>- Display shut-down after timeout was activated.</p>	<p>* Press any key or switch off timeout. ⇒ Chapter 9.7.8 "Timeout operation"</p>

15 Behavior of Outputs

Operating status	Relay output controller K1	Relay output limit value K2	Analog output
Initialization			
Initialization phase after mains voltage – ON (for approx. 10 seconds)	Inactive	Inactive	0 mA, 0 V
Setup communication			
During reading-writing of the configuration (for approx. 5 seconds)	Inactive	Limit value monitoring active ⇒ Chapter 9.4	Scaled analog signal is output ⇒ Chapter 9.6
Standard operation			
System in error-free state after initialization phase	Setpoint value monitoring active ⇒ Chapter 9.3	Monitoring of limit value depending on configuration ⇒ Chapter 9.4	Scaled analog signal is output ⇒ Chapter 9.6
External error			
Probe break, probe short circuit (e.g. input 1)	Inactive	Configured error signal is output ⇒ Chapter 9.4.4	Configured error signal is output ⇒ Chapter 9.6.5
Internal error			
Internal error, diagnostic channel	Inactive	Configured error signal is output	
Internal error, safety channel	Inactive	Configured error signal is output	

16 Certificates

Translation EU-Type Examination Certificate



- (1) **Equipment and protective systems**
intended for use in potentially
explosive atmospheres, **Directive 2014/34/EU**

(3) **Certificate Number** TÜV 15 ATEX 163874 X

Issue: 00

(4) **for the product:** JUMO exTHERM-DR

(5) **of the manufacturer:** JUMO GmbH & Co. KG

(6) **Address:** Moritz-Juchheim-Strasse 1
36039 Fulda
Germany

Order number: 8003017130

Date of issue: 2020-07-01

(7) The design of this product and any acceptable variation thereto are specified in the schedule to this EU-Type Examination Certificate and the documents therein referred to.

(8) The TÜV NORD CERT GmbH, Notified Body No. 0044, in accordance with Article 17 of the Directive 2014/34/EU of the European Parliament and the Council of 26 February 2014, certifies that this product has been found to comply with the Essential Health and Safety Requirements relating to the design and construction of products intended for use in potentially explosive atmospheres given in Annex II to the Directive.

The examination and test results are recorded in the confidential ATEX Assessment Report No. 20 203 266472.

(9) Compliance with the Essential Health and Safety Requirements has been assured by compliance with:

EN IEC 60079-0:2018

EN 60079-11:2012

except in respect of those requirements listed at item 18 of the schedule.

(10) If the sign "X" is placed after the certificate number, it indicates that the product is subject to the Specific Conditions for Use specified in the schedule to this certificate.

(11) This EU-Type Examination Certificate relates only to the design, and construction of the specified product. Further requirements of the Directive apply to the manufacturing process and supply of this equipment. These are not covered by this certificate.

(12) The marking of the product shall include the following:

 II (1) G [Ex Ia Ga] IIC or
II (1) D [Ex Ia Da] IIIC

TÜV NORD CERT GmbH, Langemannstraße 20, 45141 Essen, notified by the central office of the countries for safety engineering (ZS), Ident. Nr. 0044, legal successor of the TÜV NORD CERT GmbH & Co. KG Ident. Nr. 0032

The head of the notified body



Kroder

Hannover office, Am TÜV 1, 30619 Hannover, Tel. +49 511 998-61455, Fax +49 511 998-61590



(13) SCHEDULE

(14) EU-Type Examination Certificate No. TÜV 15 ATEX 163874 X Issue 00

(15) Description of product:

The JUMO EXTHERM-DR type 701055 / * * * is a microprocessor-based designed as a two point controller, in the following called controller. The controller has the task to regulate a channel.

The device has to be mounted on a mounting rail outside the hazardous area. It has a universal input. The inputs can measure the resistance thermometer PT100/PT1000, temperature element and a 4...20 mA standard signal.

The device has two relay outputs, one binary input and one analog output with (0) 4...20mA or (0) 2...10 V. The used universal input will be read out by the diagnostic-display unit.

For the visualization of the measured values, for configuration and for display of error reports a graphic display and LED are available. The device can be configured with a PC-program about a USB interface.

The connection of the sensors, of the relays, of the binary inputs, of the analog output and of the power supply is via printed circuit terminal for a cross section up to 2,5 mm².

Type code:

701055 Basic type

EXTHERM-DR

Version

8 Factory settings

9 According to customer specifications

Power supply

23AC 110...240 V + 10 % / - 15 %; 48...63 Hz

25AC /DC 20...30 V 48...63 Hz

701055 / * * *

Electrical data:

For TYPE 70/055 / 8 – 23:
Supply circuit
(Terminals N and L1)

only for the connection to a non-intrinsically safe circuit with a safety-related maximum voltage of:

$U_{i1} = 110 \text{ V}$ up to 240 V a.c. +10% / -15%, 48 up to 63 Hz
 $U_{m1} = 264 \text{ V}$

For TYPE 70/055 / 8 – 25:
Supply circuit
(Terminals L- and L+)

only for the connection to a non-intrinsically safe circuit with a safety-related maximum voltage of:

$U_{i1} = 20 \text{ V}$ up to 30 V d.c. or a.c., 48 up to 63 Hz
 $U_{m1} = 250 \text{ V}$

For all Types:

Binary connection
(Terminals 4 and 5)

only for the connection to a non-intrinsically safe circuit with a safety-related maximum voltage of:

$U_{m1} = 250 \text{ V}$

Analogue connection
(Terminals 9 and 10)

only for the connection to a non-intrinsically safe circuit with a safety-related maximum voltage of:

$U_{m1} = 250 \text{ V}$

Relay connection
(Terminals 11, 12, 13)

only for the connection to a non-intrinsically safe circuit with a safety-related maximum voltage and current of:

$U_{m1} = 250 \text{ V}$
 $I_{max1} = 3 \text{ A}$

Relay connection
(Terminals 14, 15, 16)

only for the connection to a non-intrinsically safe circuit with a safety-related maximum voltage and current of:

$U_{m1} = 250 \text{ V}$
 $I_{max1} = 3 \text{ A}$

USB connection
(USB-socket)

only for the connection to a non-intrinsically safe circuit with a safety-related maximum voltage and current of:

$U_{m1} = 250 \text{ V}$

Universal input
(Terminals 1, 2, 3 and 5, 6, 7)

in type of protection intrinsic safety Ex Ia IIIC resp. Ex Ia IIIC with the following maximum values per circuit:

$U_0 = 6 \text{ V}$
 $I_0 = 41,2 \text{ mA}$
 $P_0 = 61,8 \text{ mW}$
Characteristic line: linear
The effective internal capacitance C_0 is 3,7 μF .
The effective internal inductance L_0 is negligibly small.

Schedule to EU-Type Examination Certificate No. TÜV 15 ATEX 163874 X Issue 00

The maximum permissible values for the external inductance L_e and the external capacitance C_e have to be taken from the following table:

Ex ia IIC	L_e [mH]	0.2	0.1	0.05	0.02	0.01	0.001
	C_e [μ F]	0.2	1	2.1	4.3	7.3	36.3
Ex ia IIIC	L_e [mH]	100	50	20	10	0.2	0.001
	C_e [μ F]	3.6	5.4	7.3	8.3	27.3	996.3

The values of the table below are only applicable, if the internal inductance L_i (without the cable) or the internal capacitance C_i (without the cable) of the connected equipment is $\leq 1\%$ of the below specified values.
 If L_i (without the cable) and C_i (without the cable) of the connected equipment are $> 1\%$ of the specified values, the specified values of L_e shall be reduced to 50 %.
 The reduced capacitance of the external circuit (including cable) shall not exceed 1 μ F for group IIIC and 600 nF for group IIC.

Ex ia	IIC	IIIC
Maximum permissible external inductance	20 mH	83 mH
Maximum permissible external capacitance	36.3 μ F	996.3 μ F

For the temperature probes listed below, which have to be considered as simple apparatus and which is to be operated with the device, the limit value for the maximum permissible upper limit of the ambient temperature according to the temperature class resp. the maximum surface temperature has to be taken from the following table:

Temperature class resp. maximum surface temperature	Upper limit of the medium and ambient temperature for applications requiring devices of equipment protection level Gb resp. Db		Upper limit of the medium and ambient temperature for applications requiring devices of equipment protection level Ga resp. Da	
	Temperature probes with PT100	Temperature probes with thermocouple	Temperature probes with PT100	Temperature probes with thermocouple
T1 / 445 °C	432.5 °C	439.1 °C	342.5 °C	349.1 °C
T2 / 295 °C	282.5 °C	289.1 °C	222.5 °C	229.1 °C
T3 / 195 °C	187.5 °C	194.1 °C	147.5 °C	154.1 °C
T4 / 130 °C	122.5 °C	129.1 °C	95.5 °C	102.1 °C
T5 / 95 °C	87.5 °C	94.1 °C	67.5 °C	74.1 °C
T6 / 90 °C	72.5 °C	79.1 °C	55.5 °C	62.1 °C

Schedule to EU-Type Examination Certificate No. TÜV 15 ATEX 163874 X Issue 00

The following temperature probes of the manufacturer with PT100 resistor-type thermometer are intended to be operated with the device:

Type designation of the manufacturer	Replacement character xxx
902006/65-228-1003-1-15-xxx-668/922	500, 710 and 1000
902006/65-228-1003-1-15-xxx-254/922	
902006/65-228-2003-1-15-xxx-668/922	
902006/65-228-2003-1-15-xxx-254/922	
902006/10-402-1003-1-9-xxx-104/922	100, 150 and 200
902006/10-402-2003-1-9-xxx-104/922	
902006/10-226-1003-1-9-xxx-104/922	250
902006/10-226-2003-1-9-xxx-104/922	
902006/64-227-1003-1-15-xxx-254/922	710
902006/64-227-2003-1-15-xxx-254/922	
902006/63-505-2003-1-12-xxx-815/922	190
902006/63-505-1003-1-12-xxx-815/922	
902006/63-507-2003-1-12-xxx-815/922	100, 160, 190 and 220
902006/63-507-1003-1-12-xxx-815/922	100, 160 and 220
902006/63-505-3003-1-12-xxx-815/922	
902006/40-226-1003-1-12-xxx-815/922	
902006/10-390-1003-1-9-xxx-104/922	250



Schedule to EU-1-Type Examination Certificate No. TÜV 15 ATEX 163874 X Issue 00

The following temperature probes of the manufacturer with thermocouple are intended to be operated with the device:

Type designation of the manufacturer	Replacement character xxx
901006/65-547-2043-15-xxx-688/922 901006/65-546-2042-15-xxx-688/922	500, 710 and 1000
901006/66-550-2043-6-xxx-688/922 901006/66-880-1044-6-xxx-688/922 901006/66-880-2044-6-xxx-688/922 901006/66-953-1046-6-xxx-688/922 901006/66-953-2046-6-xxx-688/922	250, 355 and 500
901006/54-544-2043-15-xxx-254/922 901006/54-544-1043-15-xxx-254/922 901006/54-544-2042-15-xxx-254/922 901006/54-544-1042-15-xxx-254/922	710
901006/53-543-1042-12-xxx-815/922 901006/53-543-2042-12-xxx-815/922	220
901006/45-551-2043-2-EL-11-AL/922	50<EL<2000; 1000<AL<20000

Thermal data:

Permissible ambient temperature range during operation 0 °C ≤ T_a ≤ +55 °C

(16) Drawings and documents are listed in the ATEX Assessment Report No. 20 203 266472

Schedule to EU-1Type Examination Certificate No. TÜV 15 ATEX 163874 X Issue 00

(17) Specific Conditions for Use

1. The switching on the intrinsically safe circuits may be performed only if the J JUMO exTHERM-DR type 701055 / * - * including all supply lines is de-energized.
2. To energize the JUMO exTHERM-DR type 701055 / * - * including all supply lines, the protective cap of the intrinsically safe circuits shall be correctly mounted.
3. The sensors listed under the specifications of JUMO GmbH & Co KG based on the JUMO-datasheet 901006 and 902006 have no safe isolation to the armature. The sensor connections are therefore to be considered as grounded for the safety assessment. This means that the user must ensure in case of connection of the intrinsically safe circuit to the local potential (eg PA resp. FB) that the intrinsic safety of the JUMO exTHERM-DR type 701055 / * - * is not repealed.
4. The sensor connection heads do not meet the requirements of the material composition of EN IEC 60079-0:2018 for applications that require devices of category 1. The device has to be installed in such a way that any ignition hazards caused by impact or friction can be excluded.

**(18) Essential Health and Safety Requirements
No additional ones**

- End of Certificate -

16.2 IECEX TÜV Nord

 <h2 style="text-align: center;">IECEX Certificate of Conformity</h2>		
INTERNATIONAL ELECTROTECHNICAL COMMISSION IEC Certification System for Explosive Atmospheres <small>for rules and details of the IECEX Scheme visit www.ieceex.com</small>		
Certificate No.:	IECEX TUN 16.0022X	Page 1 of 4
Status:	Current	Issue No. 2
Date of Issue:	2023-06-07	Certificate history: Issue 1 (2020-07-01) Issue 0 (2017-07-05)
Applicant:	JUMO GmbH & Co. KG Moritz-Juchaczem-Strasse 1 56039 Fulda Germany	
Equipment:	JUMO xTHERM-DR	
Optional accessory:	701065 / * * *	
Type of Protection:	Intrinsic safety	
Marking:	[Ex ia Ga] IIC or [Ex ia Da] IIC	
Approved for issue on behalf of the IECEX Certification Body:	Thomas Heinen	
Position:	Deputy Head of IECEX Certification Body	
Signature: (for printed version)		Digital authentication von Heinen,Thomas TUVNORD Datum: 2023.06.07 11.51.32 +02'00'
Date: (for printed version)		
<p>1. This certificate and schedule may only be reproduced in full.</p> <p>2. This certificate is not valid unless issued in the context of the issuing body.</p> <p>3. The Status and authenticity of this certificate may be verified by visiting www.ieceex.com or use of this QR Code.</p>		
		
<p>Certificate issued by:</p> <p>TÜV NORD CERT GmbH Hannover Office Am TÜV 1, 30519 Hannover Germany</p> <p style="text-align: right;"></p>		



IECEX Certificate of Conformity

Certificate No.:

IECEX TUN 16.0022X

Page 2 of 4

Date of Issue:

2023-06-07

Issue No: 2

Manufacturer:

JUMO GmbH & Co. KG
Moritz-Luchtern-Strasse 1
36039 Fulda
Germany

Manufacturing
locations:

This certificate is issued as verification that a sample(s), representative of production, was assessed and tested and found to comply with the IEC Standard list below and that the manufacturing quality system, relating to the Ex products covered by this certificate, was assessed and found to comply with the IECEx Quality system requirements. This certificate is granted subject to the conditions as set out in IECEx Scheme Rules, IECEx 02 and Operational Documents as amended

STANDARDS:

The equipment and any acceptable variations to it specified in the schedule of this certificate and the identified documents, was found to comply with the following standards

IEC 60079-0:2017

Explosive atmospheres - Part 0: Equipment - General requirements

Edition: 7.0

IEC 60079-11:2011

Explosive atmospheres - Part 11: Equipment protection by intrinsic safety "T"

Edition: 6.0

This Certificate **does not** indicate compliance with safety and performance requirements other than those expressly included in the Standards listed above.

TEST & ASSESSMENT REPORTS:

A sample(s) of the equipment listed has successfully met the examination and test requirements as recorded in:

Test Reports:

DETUNE.XTR15.0047/01

DETUNE.XTR15.0047/02

Quality Assessment Report:

DE/EPDAR23.0003/00



IECEx Certificate of Conformity

Certificate No.: **IECEx TUN 16.0022X**

Page 3 of 4

Date of Issue: **2023-06-07**

Issue No: 2

EQUIPMENT:

Equipment and systems covered by this Certificate are as follows:

Description

The JUMO exTHERM-DR type 701055 / * - * is a microprocessor-based designed as a two point controller. In the following called controller. The controller has the task to regulate a channel.

The device has to be mounted on a mounting rail outside the hazardous area. It has a universal input.

The inputs can measure the resistance thermometer PT1000PT1000, temperature element and a 4...20 mA standard signal.

The device has two relay outputs, one binary input and one analog output with (0) 4...20mA or (0) 2...10 V. The used universal input will be read out by the diagnostic-display unit.

For the visualization of the measured values, for configuration and for display of error reports a graphic display and LED are available. The device can be configured with a PC-program about a USB interface.

The connection of the sensors, of the relays, of the binary inputs, of the analog output and of the power supply is via printed circuit terminal for a cross section up to 2.5 mm².

Type code and Electrical data:
See the attachment to IECEx TUN 16.0022X issue No.2

Thermal data:

Permissible ambient temperature range during operation: 0 °C ≤ T_a ≤ +55 °C

SPECIFIC CONDITIONS OF USE: YES as shown below:

- The switching on the intrinsically safe circuits may be performed only if the JUMO exTHERM-DR type 701055 / * - * including all supply lines is de-energized.
- To energize the JUMO exTHERM-DR type 701055 / * - * including all supply lines, the protective cap of the intrinsically safe circuits shall be correctly mounted.
- The sensors listed under the specifications of JUMO GmbH & Co KG based on the JUMO-datasheet 901006 and 902006 have no safe isolation to the armature. The sensor connections are therefore to be considered as grounded for the safety assessment. This means that the user must ensure in case of connection of the intrinsically safe circuit to the local potential (eg PA resp. FB) that the intrinsic safety of the JUMO exTHERM-DR type 701055 / * - * is not repealed.
- The sensor connection boards do not meet the requirements of IEC 60079-0:2017 for applications that require devices of category 1. The device has to be installed in such a way that any ignition hazards caused by impact or friction can be excluded.



IECEx Certificate of Conformity

Certificate No.: **IECEx TUN 16.0022X**

Page 4 of 4

Date of Issue: 2023-06-07

Issue No: 2

DETAILS OF CERTIFICATE CHANGES (for Issues 1 and above)

The QAR No. DE/TUN/QAR13.0005 has been replaced by DE/PS/QAR 23.0003

Annex:

[Attachment to IECEx TUN 16.0022X Issue No.2.pdf](#)

TÜV NORD CERT GmbH
Hannover Office
Am TÜV 1
30659 Hannover
Germany



Page 1 of 5
Attachment to IECEx TUN 16.0022X Issue No.: 2

Description:

The J1110 exTHERM-DR type 701055 / * - * is a microprocessor-based designed as a two port controller, in the following called controller. The controller has the task to regulate a channel.

The device has to be mounted on a mounting rail outside the hazardous area. It has a universal input. The inputs can measure the resistance thermometer PTT100/PT1000, temperature element and a 4...20 mA standard signal.

The device has two relay outputs, one binary input and one analog output with (I) 4...20mA or (O) 2...10 V. The used universal input will be read out by the diagnostic-display unit. For the visualization of the measured values, for configuration and for display of error reports a graphic display and LED are available. The device can be configured with a PC, program about a USB interface.

The connection of the sensors, of the relays, of the binary inputs, of the analog output and of the power supply is via printed circuit terminal for a cross section up to 2,5 mm².

Type code	Basic type
701055	ETHERM-DR
	Version
	8 Factory settings
	9 According to customer specifications
	Power supply
	23 AC 110...240 V + 10 % / -15 %; 48...63 Hz
	25 AC/DC 20...30 V 48...63 Hz
701055 / *	*

Electrical data:

For Exia Z01055 I/8 – 23:

Supply circuit
(Terminals N and L1)

only for the connection to a non-intrinsically safe circuit with
a safety-related maximum voltage of:

$U_M = 110$ up to 240 V a.c. +10% / -15%, 48 up to 63 Hz
 $U_M = 254$ V

For Exia Z01055 I/8 – 23:

Supply circuit
(Terminals L-, and L+)

only for the connection to a non-intrinsically safe circuit with
a safety-related maximum voltage of:

$U_M = 20$ up to 30 V d.c. or a.c., 48 up to 63 Hz
 $U_M = 250$ V

For all types:

Energy correction
(Terminals 4 and 5)

only for the connection to a non-intrinsically safe circuit with
a safety-related maximum voltage of:

$U_M = 250$ V

Analogue connection
(Terminals 9 and 10)

only for the connection to a non-intrinsically safe circuit with
a safety-related maximum voltage of:

$U_M = 250$ V

Relay connection
(Terminals 11, 12, 13)

only for the connection to a non-intrinsically safe circuit with
a safety-related maximum voltage and current of:

$U_M = 250$ V
 $I_{Mn} = 3$ A

Relay connection
(Terminals 14, 15, 16)

only for the connection to a non-intrinsically safe circuit with
a safety-related maximum voltage and current of:

$U_M = 250$ V
 $I_{Mn} = 3$ A

USB connection
(USB-socket)

only for the connection to a non-intrinsically safe circuit with
a safety-related maximum voltage and current of:

$U_M = 250$ V

Universal input
(Terminals 1, 2, 3 and 5, 6, 7)

In type of protection intrinsic safety/Ex ia IIC resp. Ex ia IIIC
with the following maximum values per circuit:

$U_M = 6$ V
 $I_M = 41,2$ mA
 $P_M = 0,18$ mW
Characteristic line: linear
The effective internal capacitance C is $\leq 3,7$ µF.
The effective internal inductance L is negligibly small.

TÜV NORD CERT GmbH
Hannover Office
Am TÜV/1
30519 Hannover
Germany



Page 3 of 5
Attachment to IECEx TUV 15.0022X Issue No.: 2

The maximum permissible values for the external inductance L_e and the external capacitance C_e have to be taken from the following table:

Ex Ia IIC	L_e [mH]	0.2	0.05	0.02	0.01	0.001	
	C_e [pF]	0.2	1	2.1	4.3	7.3	36.3
Ex Ia IIC	L_e [mH]	100	50	20	10	0.2	0.001
	C_e [pF]	3.6	5.4	7.3	8.3	27.3	96.3

The values of the table below are only applicable, if the internal inductance L_i (without the cable) or the internal capacitance C_i (without the cable) of the connected equipment is $\leq 1\%$ of the below specified values.

If L_i (without the cable) and C_i (without the cable) of the connected equipment are $> 1\%$ of the specified values, the specified values of L_e shall be reduced to 50 %.

The reduced capacitance of the external circuit (including cable) shall not exceed 1 μ F for group IIC and 600 nF for group IIC.

Ex Ia	Maximum permissible external inductance	IIC	20 mH	IIC	83 mH
	Maximum permissible external capacitance		36.3 μ F		96.3 μ F

For the temperature probes listed below, which have to be considered as simple apparatus and which to be operated with the device, the min value for the maximum permissible upper limit of the ambient temperature according to the temperature class resp. the maximum surface temperature has to be taken from the following table:

Temperature class resp. maximum surface temperature	Upper limit of the medium and ambient temperature for applications requiring devices for equipment protection level Gb resp. Db		Upper limit of the medium and ambient temperature for applications requiring devices of equipment protection level Ca resp. Da	
	Temperature probes with PTT100	Temperature probes with Ferrocouple	Temperature probes with PTT100	Temperature probes with thermocouple
T1 / 445 °C	432.5 °C	439.1 °C	342.5 °C	349.1 °C
T2 / 295 °C	282.5 °C	289.1 °C	222.5 °C	229.1 °C
T3 / 195 °C	182.5 °C	184.1 °C	147.5 °C	154.1 °C
T4 / 130 °C	122.5 °C	129.1 °C	95.5 °C	102.1 °C
T5 / 95 °C	87.5 °C	94.1 °C	67.5 °C	74.1 °C
T6 / 60 °C	72.5 °C	79.1 °C	55.5 °C	62.1 °C

Page 4 of 5
 Attachment to IECEx TUN 16.0022X Issue No.: 2

The following temperature probes of the manufacturer with PT 100 resistor-type thermometer are intended to be operated with the device:

Type designation of the manufacturer	Replacement character:xxx
902006/65-228-1003-1-15-xxx-6889/922	500, 710 and 1000
902006/65-228-1003-1-15-xxx-2549/922	
902006/65-228-2003-1-15-xxx-6889/922	
902006/65-228-2003-1-15-xxx-2549/922	
902006/10-402-1003-1-8-xxx-1046/922	100, 150 and 200
902006/10-402-2003-1-8-xxx-1046/922	
902006/10-226-1003-1-8-xxx-1046/922	250
902006/10-226-2003-1-8-xxx-1046/922	
902006/54-227-1003-1-15-xxx-2549/922	710
902006/54-227-2003-1-15-xxx-2549/922	
902006/53-505-2003-1-12-xxx-8159/922	190
902006/53-505-1003-1-12-xxx-8159/922	
902006/53-507-2003-1-12-xxx-8159/922	100, 160, 190 and 220
902006/53-507-1003-1-12-xxx-8159/922	
902006/53-505-3003-1-12-xxx-8159/922	100, 160 and 220
902006/40-226-1003-1-12-xxx-8159/922	
902006/10-390-1003-1-8-xxx-1046/922	250

The following temperature probes of the manufacturer with thermocouple are intended to be operated with the device:

Type designation of the manufacturer	Replacement character:xxx
901006/65-547-2043-1-15-xxx-6889/922	500, 710 and 1000
901006/65-546-2042-1-15-xxx-6889/922	
901006/66-550-2043-8-xxx-6889/922	250, 395 and 500
901006/66-890-1044-6-xxx-6889/922	
901006/66-890-2044-6-xxx-6889/922	
901006/66-953-1046-6-xxx-6889/922	
901006/66-953-2046-6-xxx-6889/922	
901006/54-544-2043-1-15-xxx-2549/922	710
901006/54-544-1043-1-15-xxx-2549/922	
901006/54-544-2042-1-15-xxx-2549/922	
901006/54-544-1042-1-15-xxx-2549/922	
901006/53-543-1043-12-xxx-8159/922	220
901006/53-543-2042-12-xxx-8159/922	
901006/45-551-2043-2-EL-11-AL/922	50<EL<2000, 1000<AL<20000

TUV NORD CERT GmbH
Hannover Office
Am TÜV 1
30519 Hannover
Germany



Page 5 of 5
Attachment to IECEx TÜN 16.0022X Issue No.: 2

Thermal data:

Permissible ambient temperature range during operation: 0 °C ≤ T_a ≤ +55 °C

Specific Conditions of Use

1. The switching on the intrinsically safe circuits may be performed only if the JUMO exTHERM-DR type 701055 / - * including all supply lines is de-energized.
2. To energize the JUMO exTHERM-DR type 701055 / - * including all supply lines, the protective cap of the intrinsically safe circuits shall be correctly mounted.
3. The sensors listed under the specifications of JUMO GmbH & Co KG based on the JUMO-datasheet 901006 and 902006 have no safe isolation to the armature. The sensor connections are therefore to be considered as grounded for the safety assessment. This means that the user must ensure in case of connection of the intrinsically safe circuit to the local potential (eg PA resp. FB) that the intrinsic safety of the JUMO exTHERM-DR type 701055 / - * is not repeated.
4. The sensor connection heads do not meet the requirements of the material composition of IEC 60079-0:2017 for applications that require devices of category 1. The device has to be installed in such a way that any ignition hazards caused by impact or friction can be excluded.



IECEx Certificate of Conformity

INTERNATIONAL ELECTROTECHNICAL COMMISSION
IEC Certification System for Explosive Atmospheres
for rules and details of the IECEx Scheme visit www.iecex.com

Certificate No.: IECEx SEV 22 0017X Page 1 of 5 Certificate history:
Issue 0 (2022-11-15)

Issue No.: 1

Issue 0 (2022-11-15)

Status: Current
Date of Issue: 2023-04-27

Applicant: JUMO GmbH & Co. KG
Münch. Außen-Strasse 1
36039 Fulda
Germany

Equipment: Two-State Controller with Ex (eb) Input JUMO EXTHERM DR, Type 701025 / - - - 23 / 045 and Type 701051 / - - -
- 25 / 045

Optional accessory: --

Type of Protection: "e", "r"

Marking: [Ex eb Gb] IIC
[Ex Ib Dtl] IIC



Approved for issue on behalf of the IECEx
Certification Body:

Thomas Köhnopp

Position:

Manager Product Certification

Signature:

(for printed version)

Date: (for printed version) 2023-04-27

1. This certificate and schedule may only be reproduced in full.
2. This certificate is not transferable and remains the property of the issuing body.
3. The Status and authenticity of this certificate may be verified by visiting www.iecex.com or via the QR Code.



Certificate issued by:

Eurofins Electric & Electronic Product Testing AG
Luppenstrasse 3
8250 FHN/ALTOPI,
Switzerland





IECEX Certificate of Conformity

Certificate No.:

IECEX SEV 22.0017X

Page 2 of 5

Date of Issue:

2023-04-27

Issue No.: 1

Manufacturer:

JUMO GmbH & Co. KG
Meyritz-Luchtheim-Strasse 1
36039 Fulda
Germany

Manufacturing

Locations:

This certificate is issued as verification that a sample(s), representative of production, was assessed and tested and found to comply with the IEC Standard listed below and that the manufacturer's quality system, relating to the Ex products covered by this certificate, was assessed and found to comply with the IECEx Quality system requirements. This certificate is granted subject to the conditions as set out in IECEx Scheme Rules, IECEx 02 and Operational Documents as amended

STANDARDS :

The equipment and any acceptable variations to it specified in the schedule of this certificate and the identified documents, was found to comply with the following standards

- IEC 60079-0:2017 Explosive atmospheres - Part 0: Equipment - General requirements
Edition: 7.0
- IEC 60079-31:2013 Explosive atmospheres - Part 31: Equipment dust ignition protection by enclosure "T"
Edition: 2
- IEC 60079-7:2017 Explosive atmospheres - Part 7: Equipment protection by increased safety "v"
Edition: 3.1

This Certificate does not indicate compliance with safety and performance requirements other than those expressly included in the Standards listed above.

TEST & ASSESSMENT REPORTS:

A sample(s) of the equipment listed has successfully met the examination and test requirements as recorded in:

Test Report:

CH/SEV/EXT/22.0018/00

Quality Assessment Report:

DE/PS/QAR/23.0003/00

Certificate No.: IECEx SEV 22.0017X

Page 3 of 5

Date of Issue: 2023-04-27

Issue No: 1

EQUIPMENT:

Equipment and systems covered by this Certificate are as follows:

The JUMO exTHERM-DR is a hardware controller for heating or cooling applications. The safe Ex (eb) measuring input allows the direct connection of the corresponding type sealed probes. Use of a barrier is no longer required. Other than the relay output, "Control" K1, JUMO exTHERM-DR also has the second relay output K2. It signals when limit values have been exceeded or are not met.

Alternatively, a binary signal of 0/10 V is also available for the controller output or the limit value signaling.

The current measured value or the setpoint value is issued via the standard analog output.

The vibrant display for plain text and with backlight shows information about measured value, setpoint value, limits value, etc. in a clearly arranged manner.

Clear operation enables quick configuration and thereby reduces the startup times.

Alternatively, the configuration and parameterization can also take place via a setup program and the standard USB interface.

Parameters:**For Types exTHERM-DR 701055 / - - 23 / 045**

Supply circuit only for the connection to a non-intrinsically safe circuit with a (Terminals N and L1) safety-related maximum voltage of

U_m = 110 up to 240 V AC +10% / -15%, 48 up to 63 HzU_m = 250 V**For Types exTHERM-DR 701055 / - - 25 / 045**

Supply circuit only for the connection to a non-intrinsically safe circuit with a (Terminals L- and L+) safety-related maximum voltage of

U_m = 20 up to 30 V DC or AC, 48 up to 63 HzU_m = 250 V**For all types**

Basic protection only for the connection to a non-intrinsically safe circuit with a (Terminals 4 and 5) safety-related maximum voltage of

U_m = 250 V

Analogous connection only for the connection to a non-intrinsically safe circuit with a (Terminals 6 and 10) safety-related maximum voltage of

U_m = 250 V

Relay connection only for the connection to a non-intrinsically safe circuit with a

(Terminals 11, 12, 13) safety-related maximum voltage and current of

U_m = 250 VI_{max} = 3 A

Relay connection only for the connection to a non-intrinsically safe circuit with a

(Terminals 14, 15, 16) safety-related maximum voltage and current of

U_m = 250 VI_{max} = 3 A

USB-socket(s) safety-related maximum voltage of

U_m = 250 V

USB-socket(s) safety-related maximum voltage of

U_m = 250 V

Output circuit in type of protection for increased safety [Ex eb] IIC resp. IIC with the (Terminals 1, 2, 3 and 6, 7, 8) following maximum values

per output:

U₀ = 48 VI₀ = 41 mAI₀ = 61.8 mACharacteristic time: t_{max} **SPECIFIC CONDITIONS OF USE: YES as shown below:**

- Switching operations may be performed on the electrical circuits (Ex eb) only when the JUMO exTHERM-DR, including all supply lines, is de-energized.
- If it is installed in a separate electrical cabinet, the following warning must be attached to the outside of the electrical cabinet: WARNING: "Caution - This enclosure contains equipment that is part of an ignition protection system according to ISO 80075-37."



IECEx Certificate of Conformity

Certificate No.: IECEx SEV 22.0017X

Date of issue: 2023-04-27

Page 4 of 5

Issue No.: 1

Equipment (continue):

Classification of installation and use : Stationary

Ingress protection : IP20

Rated ambient temperature range (°C) : 0 °C ... +55 °C

Rated service temperature range (°C) for Ex Components : ---





IECEx Certificate of Conformity

Certificate No.: IECEx SEV 22.0017X

Page 5 of 5

Date of issue: 2023-04-27

Issue No: 1

DETAILS OF CERTIFICATE CHANGES (for Issues 1 and above)

Change of EUCB for quality system. Link to QMS updated.



16.4 Ex „e“ und „t“



EU-Type Examination Certificate

- (1) **Equipment or protective system intended for use in potentially explosive atmospheres - Directive 2014/34/EU**
Certificate number: **SEV 17 ATEX 0177 X**
- (2) **Product:** Two-State Controller JUMO exTHERM-DR
- (3) **Manufacturer:** JUMO GmbH & Co. KG
- (4) **Address:** Moritz-Juchheim-Strasse 1, 36039 Fulda, Germany
- (5) The equipment and any acceptable variation thereto is specified in the schedule to this certificate and the documents therein referred to.
- (6) Eurofins, notified body No. 1256, in accordance with article 17 of Directive 2014/34/EU of the European parliament and of the council, dated 26 February 2014, certifies that this product has been found to comply with the essential health and safety requirements relating to the design and construction of products intended for use in potentially explosive atmospheres given in Annex II to the Directive.
- (7) The examination and test results are recorded in confidential report no 21CH-00125_X12
- (8) Compliance with the essential health and safety requirements has been assured by compliance with:

EN IEC 60079-0:2018
EN 60079-2:2015
EN IEC 60079-7:2015A1:2018
EN 60079-31:2014

(10) Except in respect of those requirements listed at item 18 of the schedule.

(11) If the sign «X» is placed after the certificate number, it indicates that the product is subjected to special conditions for safe use specified in the schedule to this certificate. The sign „U“ is placed after the certificate number. It indicates that this certificate must not be mistaken for a certificate intended for an equipment or protective system. This partial certificate may be used as a basis for certification of an equipment or protective system.

(12) This EU type examination certificate relates only to design and construction of the specified product. Further requirements of this directive apply to the manufacturing process and supply of the product. These are not covered by this certificate.

The marking of the product shall include the following:



Eurofins Electric & Electronic Product Testing AG
Notified Body ATEX

Patrick Gutsmann
Product Certification

www.eurofins.ch Fehraltorf, 2022-11-15

Issue: 1

Page 1 of 3

TBA_V01



(13) **Appendix**

(14) **EU-Type Examination Certificate no. SEV 17 ATEX 0177 X**

(15) **Description of product**

The JUMO exTHERM-DR is a two-state controller for heating or cooling applications. The safe Ex (nb) measuring input allows the direct connection of the corresponding type-tested probes. Use of a burner is no longer required.

Other than the relay output "Controller" K1, JUMO exTHERM-DR also has the second relay output K2. Its signals when limit values have been exceeded or are not met.

Alternatively, a binary signal of 0/10 V is also available for the controller output or the limit value signaling.

The current measured value or the setpoint value is issued via the standard analog output.

The vibrant display for plain text and with backlight shows information about measured value, setpoint value, limits value, etc. in a clearly arranged manner.

Clear operation enables quick configuration and thereby reduces the startup time.

Alternatively, the configuration and parameterization can also take place via a setup program and the standard USB interface.

Parameters:

For Types exTHERM-DR 701055 / * - 23 / 045

Supply circuit only for the connection to a non-intrinsically safe circuit with a (Terminals N and L1) safety-related maximum voltage of

U_n = 110 up to 240 V AC +10% / -15%, 48 up to 63 Hz

U_n = 250 V

For Types exTHERM-DR 701055 / * - 25 / 045

Supply circuit only for the connection to a non-intrinsically safe circuit with a (Terminals L- and L+*) safety-related maximum voltage of

U_n = 20 up to 30 V DC or AC, 48 up to 63 Hz

U_n = 250 V

For all types

Bony connection only for the connection to a non-intrinsically safe circuit with a (Terminals 4 and 5) safety-related maximum voltage of

U_n = 250 V

Analog connection only for the connection to a non-intrinsically safe circuit with a (Terminals 9 and 10) safety-related maximum voltage of

U_n = 250 V

Relay connection only for the connection to a non-intrinsically safe circuit with a (Terminals 11, 12, 13) safety-related maximum voltage and current of

U_n = 250 V

I_{max} = 3 A

Relay connection only for the connection to a non-intrinsically safe circuit with a (Terminals 14, 15, 16) safety-related maximum voltage and current of

U_n = 250 V

I_{max} = 3 A

USB connection only for the connection to a non-intrinsically safe circuit with a (USB-socket) safety-related maximum voltage of

U_n = 250 V



Output circuit in type of protection for increased safety (Ex eb) IIC resp. IIIC with the Terminals 1, 2, 3 and 6, 7, 8) following maximum values per circuit:

$U_n = 6 \text{ V}$

$I_n = 41,2 \text{ mA}$

$P_n = 61,8 \text{ mW}$

Characteristic line: linear

Classification of installation and use : Stationary

Ingress protection : IP20

Rated ambient temperature range (°C) : 0 °C ... +55 °C

Rated service temperature range (°C) for EX Components : ---

(16) **Report number**

Z1CH-00125.X12

(17) **Specific conditions of use**

- Switching operations may be performed on the electrical circuits (Ex eb) only when the JUMO exTHERM-DR, including all supply lines, is de-energized.

(18) **Essential health and safety requirements**

In addition to the essential health and safety requirements (EHSRs) covered by the standards listed at item 9, the following are considered relevant to this product, and conformity is demonstrated in the report:

- If it is installed in a separate electrical cabinet, the following warning must be attached to the outside of this electrical cabinet: WARNING - Caution - This enclosure contains equipment that is part of an ignition protection system according to ISO 80079-37.

Clause Subject
None

(19) **Drawings and Documents**

See test report "Manufacturer's Documents"

16.5 EU-declaration of conformity

JUMO GmbH & Co. KG
 Mehr-Juchheim-Strasse 1
 38039 Fulda, Germany

Tel. +49 821 8034 0
 Fax. +49 821 8033 500

E-Mail: mail@jumo.net
 Internet: www.jumo.net



**MORE THAN SENSORS
 AND AUTOMATION**

EU-Konformitätserklärung

EU declaration of conformity / Déclaration UE de conformité

Dokument-Nr.

CE 715

Document No. / Document n°

JUMO GmbH & Co. KG

Hersteller

Manufacturer / Etalé par

Anschrift

Address / Adresse

Moritz-Juchheim-Strasse 1, 38039 Fulda, Germany

Produkt

Product / Produit

Name
 Name / Nom

Typ
 Type / Type

Typenblatt-Nr.
 Data sheet no. / N°
 Document
 identification

JUMO exTHERM-DR

701055

701055

Produktbeschreibung

Product description / Description du produit

Elektronischer Zweipunktregler mit ATEX-Zulassung

Wir erklären in alleiniger Verantwortung, dass das bezeichnete Produkt die Anforderungen der Europäischen Richtlinien erfüllt.

We hereby declare in sole responsibility that the designated product fulfills the requirements of the European Directives.

Nous déclarons sous notre seule responsabilité que le produit remplit les Directives Européennes.

Dokument-Nr.
 Document No. / Document n°

CE 715

EU-Konformitätserklärung

Seite 1 von 6

JUMO GmbH & Co. KG
Macke-Juchacz-Strasse 1
36091 Fellm. Germany

TEL: +49 691 8023-0
FAX: +49 691 8023-300

E-MAIL: mail@jumo.net
Internet: www.jumo.net



**MORE THAN SENSORS
AND AUTOMATION**

1. Richtlinie

Directive / Directive

EMC 2014/30/EU

Name

Name / Nom

Konformitätsbewertungsverfahren

Conformity assessment procedure /

Procédure d'évaluation de la conformité

Mod. A

Datum der Erstanbringung des CE-Zeichens auf dem Produkt

Date of first application of the CE mark to the product /

Date de 1^{ère} application du sigle sur le produit

Angewendete Normen/Spezifikationen

Standards/Specifications applied / Normes/Specifications appliquées

Referenz

Reference / Référence

Ausgabe

Edition / Edition

Bemerkung

Comment / Remarque

EN 60730-1

2011

EN 60730-2-9

2010

Gültig für Typ

Valid for Type / Valable pour le type

701055/...

2. Richtlinie

Directive / Directive

ATEX 2014/34/EU

Name

Name / Nom

Konformitätsbewertungsverfahren

Conformity assessment procedure /

Procédure d'évaluation de la conformité

Mod. B+D

Datum der Erstanbringung des CE-Zeichens auf dem Produkt

Date of first application of the CE mark to the product /

Date de 1^{ère} application du sigle sur le produit

Dokument-Nr.
Document No. / Document n°

CE 715

EU-Konformitätserklärung

Seite 2 von 6

JUMO GmbH & Co. KG

Maxim-Zackhausen-Strasse 1
36039 Fulda, Germany

Tel. +49 691 9323-0
Fw. +49 691 9323-500

E-Mail: mail@jumo.net
Internet: www.jumo.net



**MORE THAN SENSORS
AND AUTOMATION**

Gültig für Typ

Valid for Type / Valable pour le type

701055**-*-044

701055**-*-045

2.1 EU-Baumusterprüfbescheinigung

EU type examination certificate / Certificat d'examen de type UE

Zertifikatsnummer

TÜV 15 ATEX 163874 X

Certificate number / Numéro de certificat

Notifizierende Stelle

Notified Body / Organisme notifié

TÜV NORD CERT GmbH, Langemarckstraße
20, 45141 Essen, Germany

Angewendete Normen/Spezifikationen

Standard/Specifications applied / Normes/Spécifications appliquées

Referenz

Ausgabe

Bemerkung

Reference / Référence

Edition / Édition

Comment / Remarque

EN 60079-0

2018

EN 60079-11

2012

Gültig für Typ

Valid for Type / Valable pour le type

701055**-*-044

2.2 EU-Baumusterprüfbescheinigung

EU type examination certificate / Certificat d'examen de type UE

Zertifikatsnummer

SEV 17 ATEX 0177 X

Certificate number / Numéro de certificat

Notifizierende Stelle

Notified Body / Organisme notifié

Eurofins Electric & Electronic Product Testing
AG, Luppinnenstrasse 3, 8320 Fehraltorf,
Switzerland

Dokumenten-Nr.
Document No. / Document n°

CE 715

EU-Konformitätserklärung

Seite 3 von 6

JUMO GmbH & Co. KG
Molz-Juchacz-Str. 1 Tel. +49 89 8023-0
36089 Weilheim, Germany Fax. +49 89 8023-500

E-Mail: mail@jumo.net
Internet: www.jumo.net



MORE THAN SENSORS
AND AUTOMATION

Angewendete Normen/Spezifikationen

Standards/Specifications applied / Normes/Spécifications appliquées

Referenz	Ausgabe	Bemerkung
Reference / Référence	Edition / Edition	Comment / Remarque
EN 60079-0	2018	
EN 60079-7	2015+A1:2018	
EN 60079-31	2014	

Gültig für Typ

Valid for Type / Valable pour le type
701055F--045

Qualitätsicherung bezogen auf den Produktionsprozess

Quality assurance of the production process / L'assurance de la qualité de la production

Zertifikatsnummer

Certificate number / Numéro de certificat

Available on request

Notifizierendes Stelle

Notified Body / Organisme notifié

BUREAU VERITAS Consumer Products
Services Germany GmbH, Wilhelm-Herrmann-
Straße 8, 19081 Schwerin, Germany
2004

Kennnummer

Identification no. / N° d'identification

3. Richtlinie

Directive / Directive

RoHS 2011/65/EU

Name

Name / Nom

Mod. A

Konformitätsbewertungsverfahren

Conformity assessment procedure /

Procédure d'évaluation de la conformité

Datum der Erstanbringung des CE-Zeichens auf 2017

dem Produkt

Date of first application of the CE mark to the product /

Date de 1^{ère} application du sigle sur le produit.

Dokument-Nr.
Document No. / Document n°

CE 715

EU-Konformitätsbestätigung

Seite 4 von 6

JUMO GmbH & Co. KG
 Max-Planck-Strasse 1
 36029 Fulda, Germany

Tel. +49 661 8033-0
 Fax. +49 661 8033-500

E-Mail: mail@jumo.net
 Internet: www.jumo.net



**MORE THAN SENSORS
 AND AUTOMATION**

Angewendete Normen/Spezifikationen
 Standards/Specifications applied / Normes/Spécifications appliquées

Referenz **Ausgabe**
 Reference **Edition / Edition**
 VDK Umwelrelevante Aspekte
 bei der Produktentwicklung und
 -gestaltung V1

Bemerkung
 Comment / Remarque

Gültig für Typ

Valid for Type / Valable pour le type
 701055/...

4. Richtlinie **LVD 2014/35/EU**
 Directive / Directive
 Name

Name / Nom **Mod. A**
Konformitätsbewertungsverfahren
 Conformity assessment procedure /
 Procédure d'évaluation de la conformité

Datum der Erstanbringung des CE-Zeichens auf **2015**
 dem Produkt
 Date of first application of the CE mark to the product /
 Date de 1^{ère} application du sigle sur le produit

Angewendete Normen/Spezifikationen
 Standards/Specifications applied / Normes/Spécifications appliquées

Referenz	Ausgabe	Bemerkung
Reference / Référence	Edition / Edition	Comment / Remarque
EN 60730-1	2011	
EN 60730-2-9	2010	

Gültig für Typ

Valid for Type / Valable pour le type
 701055/...

Document Nr.
 Document No. / Document n°

CE 715

EU-Konformitätserklärung

Seite 5 von 6

JUMO GmbH & Co. KG
Maximilian-Strasse 1
36039 Fulda, Germany

Tel. +49 691 6020-0
Fax. +49 691 6020-500

E-Mail: mail@jumo.net
Internet: www.jumo.net



**MORE THAN SENSORS
AND AUTOMATION**

JUMO GmbH & Co. KG

Aussteller
Issued by / Etablí par

Ort, Datum

Place, date / Lieu, date

Rechtsverbindliche Unterschriften

Legally binding signatures /

Signatures juridiquement valables

Fulda, 2024-07-15

Bereichsleitung Globaler Vertrieb
l. V. Sewil Davarci

Leiter Managementsysteme
l. V. Mathias Raab



Dokument-Nr.
Document No. / Document n°

CE 715

EU-Konformitätsklärung

Seite: 6 von 6

17 China RoHS

	 					
产品组别 Product group: 701055	产品中有害物质的名称及含量 China EEP Hazardous Substances Information					
部件名称 Component Name						
	铅 (Pb)	汞 (Hg)	镉 (Cd)	六价铬 (Cr(VI))	多溴联苯 (PBB)	多溴二苯醚 (PBDE)
外壳 Housing (Gehäuse)	○	○	○	○	○	○
过程连接 Process connection (Prozessanschluss)	○	○	○	○	○	○
螺母 Nuts (Mutter)	○	○	○	○	○	○
螺栓 Screw (Schraube)	○	○	○	○	○	○
<p>本表格依据SJ/T 11364的规定编制。 This table is prepared in accordance with the provisions SJ/T 11364.</p> <p>○：表示该有害物质在该部件所有均质材料中的含量均在GB/T 26572规定的限量要求以下。 Indicate the hazardous substances in all homogeneous materials' for the part is below the limit of the GB/T 26572.</p> <p>×：表示该有害物质至少在该部件的某一均质材料中的含量超出GB/T 26572规定的限量要求。 Indicate the hazardous substances in at least one homogeneous materials' of the part is exceeded the limit of the GB/T 26572.</p>						



JUMO GmbH & Co. KG

Street address:
Mortiz-Juchheim-Straße 1
36039 Fulda, Germany
Delivery address:
Mackenrodtstraße 14
36039 Fulda, Germany
Postal address:
36035 Fulda, Germany
Phone: +49 661 6003-0
Fax: +49 661 6003-607
Email: mail@jumo.net
Internet: www.jumo.net

JUMO UK LTD

JUMO House
Temple Bank, Riverway
Harlow, Essex, CM20 2DY, UK
Phone: +44 1279 63 55 33
Fax: +44 1279 62 50 29
Email: sales@jumo.co.uk
Internet: www.jumo.co.uk

JUMO Process Control, Inc.

6724 Joy Road
East Syracuse, NY 13057, USA
Phone: +1 315 437 5866
Fax: +1 315 437 5860
Email: info.us@jumo.net
Internet: www.jumousa.com

