

Series D

IO-Link

USE AND MAINTENANCE MANUAL

Version: IO-LINK 1.01



Contents

1	General recommendations	1
1.1	Product storage and transport	2
1.2	Use	2
1.3	Limitations of use	2
1.4	Maintenance	2
1.5	Ecological Information	3
2	General characteristics and conditions of use	4
3	General description of the system	6
4	Recipients	7
5	Installation	8
5.1	General installation instructions	8
5.2	Connecting and warning components	8
5.2.1	Power Supply Connector and IO-Link network	9
5.2.2	USB Connector	9
5.3	Power supply	10
5.3.1	Electropilot activation rules	10
5.4	Connectable accessories	11
5.5	Assembly	12
5.5.1	Dismantling and fitting CX4 module	12
5.5.2	Series D subbases assembly	13
5.5.3	Dismantling and fitting Serie D coil valves	14
6	Accessories	15
6.1	Series D valve subbase	15
6.1.1	Technical Data	16
6.1.2	Coilvision	16
6.1.3	Features	17
6.1.4	Subbase diagnostics	17
7	Commissioning	19
7.1	Electrical connections	19
7.2	Start-up operation	19
7.3	Mapping	20
7.4	Versions	20
7.5	Configurazione tramite file IOODD	20
7.6	Addressing	20
7.6.1	Mappatura degli elettropiloti	21
7.7	Address assignment	22
7.8	Exchange data	23

7.8.1	Parameterisation	24
7.8.1.1	Modulo CX4 IO-Link	24
7.8.1.2	Series D valve sub-bases	26
7.9	Data Storage	34
7.10	Local parameterisation	34
8	Diagnostic	35
8.1	CX4 module	37
8.1.1	IO-Link node	37
8.1.2	CX4 system diagnostics	38
8.1.3	Replace solenoid valve	39
8.1.4	Over-temperature alarm	39
8.1.5	Undervoltage alarm	39
8.1.6	Solenoid valve mapping error	39
8.1.7	No mapping	39
8.1.8	Solenoid valve	39
8.2	Series D valve subbases	40
9	Uvix	41
9.1	Introduction	41
9.2	General information	42
9.2.1	Status information	43
9.2.2	Variables	44
9.2.3	Alarms	45
9.2.4	Commands	46
9.3	Series D coil valves and subbase	47
9.3.1	Status information	47
9.3.2	Configuration	48
9.3.3	Details	49
9.3.4	Variables	49
9.3.5	Alarms	50
9.3.6	Commands	51
9.4	UVIX USB Gateway	52
9.4.1	Main page	52
9.4.2	WiFi network configurator	53
9.4.3	Mapping	53
9.4.4	Firmware update	53
9.5	Communication with external applications	57
10	NFCamApp	60
10.1	Main overview	60
10.2	Main page	61
10.3	General information	62
10.4	WiFi information	63
10.5	Mapping request	64

General recommendations

▲ Please comply with the recommendations for safe use described in this document:

- Some hazards can only be associated with the product after it has been installed on the machine/equipment. It is the responsibility of the end user to identify these hazards and reduce the risks associated with them.
- For information regarding the reliability of the components, contact Camozzi Automation.
- Read the information in this document carefully before using the product.
- Keep this document in a safe place and close at hand for the whole of the product's life cycle.
- Pass this document on to any subsequent owner or user.
- The instructions in this manual must be observed in conjunction with the instructions and additional information concerning the product in this manual, available from the following reference links:
 - Website <http://www.camozzi.com>
 - Camozzi general catalogue
 - Technical assistance service
- Assembly and commissioning must be performed exclusively by qualified and authorised personnel on the basis of these instructions.
- It is the responsibility of the system/machine designer to ensure the correct selection of the most suitable pneumatic component according to the intended application.
- Use of appropriate personal protective equipment is recommended to minimise the risk of physical injury.
- For all situations not contemplated in this manual and in situations in which there is the risk of potential damage to property, or injury to persons or animals, contact Camozzi for advice.
- Do not make unauthorised modifications to the product. In this case, any damage or injury to property, persons or animals will be the responsibility of the user.
- It is recommended to comply with all safety regulations that apply to the product.
- Never intervene on the machine/system until you have verified that all working conditions are safe.
- Before installation or maintenance, ensure that the required safety locks are active, and then disconnect the electrical mains (if necessary) and system pressure supply, discharging all residual compressed air from the circuit and deactivating residual energy stored in springs, condensers, recipients and gravity.
- After installation or maintenance, the system pressure and electrical power supply (if necessary) must be reconnected, and the regular operation and sealing of the product must be checked. In the event of leaks or malfunction, the product must not be used.
- The product may only be used in observance of the specifications provided; if these requirements are not met, the product may only be used upon authorisation by Camozzi.
- Avoid covering the equipment with paint or other substances that may reduce heat dissipation.

1.1 Product storage and transport

- Adopt all measures possible to avoid accidental damage to the product during transport, and when available use the original packaging.
- Observe the specified storage temperature range of $-10 \div 50$ °C.

1.2 Use

- Make sure that the distribution network voltage and all operating conditions are within the permissible values.
- The product may only be used in observance of the specifications provided; if these requirements are not met, the product may only be used upon authorisation by Camozzi.
- Follow the indications shown on the identification plate.

1.3 Limitations of use

- Do not exceed the technical specifications given in paragraph 2 (General characteristics and conditions of use) and in the Camozzi general catalogue.
- Do not install the product in environments where the air itself may cause hazards.
- With the exception of specific intended uses, do not use the product in environments where direct contact with corrosive gases, chemicals, salt water, water or steam may occur.

1.4 Maintenance

- Incorrectly performed maintenance operations can compromise the good working order of the product and harm surrounding persons.
- Check conditions to prevent sudden release of parts, then suspend the power supply and allow residual stresses to discharge before taking action.
- Assess the possibility of having the product serviced by a technical service center.
- Never disassemble a live unit.
- Isolate the product electrically before maintenance.
- Always remove accessories before maintenance.
- Always wear the correct personal protective equipment as envisaged by local authorities and in compliance with current legislation.
- In the event of maintenance, or replacement of worn parts, exclusively use the original Camozzi kits and ensure that operations are performed by specialised and authorised personnel. Otherwise product approval will be rendered invalid.

1.5 Ecological Information

- At the end of the product's life cycle, it is recommended to separate the materials for recycling.
- Follow the waste disposal regulations in force in your country.
- The product and relative parts all comply with the ROHS and REACH standards.

General characteristics and conditions of use

ELECTRICAL SECTION	
Power and bus connection type	M12 - 5 poles
Supply voltage Logic	24 V DC +/-25%
Supply voltage Power	24 V DC +/-10%
Valve maximum absorption	2.5 A
Maximum no. valve positions	32 (64 coils)
Coil power	1W (reduction to 0.5W after 100ms)
Maximum cable length	20 m
Protocol	IO-Link  IO-Link

PNEUMATIC SECTION					
Versions		D1	D2	D4	D5
Valve construction		Spool with seals			
Valve functions		5/2 monostable and bistable		2x3/2 NC 2x3/2 NO	
		5/3 CC – CP – CO		1X3/2 NC+1X3/2 NO	
Materials	Body	Aluminium			
	Spool	Aluminium			
	Subbase	Technopolymer	Technopolymer	Aluminium	Technopolymer
	End cover	Technopolymer			
	Seal	HNBR			
Connections		Uses 2 and 4			
		Thread (only D4) or bushings, tube size variable according to the pitch			
Temperature		0 ÷ 50 °C			
Air feature		Compressed air filtered and not lubricated in class 7.4.4 according to ISO 8573-1: 2010. If lubrication is required, use only oils with max. viscosity. 32 Cst and the version with external servo drive. The servo drive air quality must be in class 7.4.4 according to ISO 8573-1: 2010 (do not lubricate).			
Valve pitch		10.5 mm	16 mm	25 mm	10.5 e 16 mm
Working pressure		-0.9 ÷ 10 bar			
Drive pressure		2.5 ÷ 7 bar 4,5 ÷ 7 bar (with working pressure higher than 6 bar for the 2x3/2 version)			
Flow rate		250 NL/min	950 NL/min	2000 NL/min	250 ÷ 950 NL/min
Assembly position		Any			
Degree of protection		IP65			

General description of the system

The CX4 IO-Link module is a device for driving valves by connecting it to a IO-Link network. The CX4 consists of a single connector for power and for communication to the IO-Link field bus and LEDs for system diagnostics. It is possible to connect the Series D coil valves on the right side of the CX4 .

Nomenclature

The CX4 module can be used by connecting D-Series solenoid valves from the pneumatic side and is called **Series D Valve Island Fieldbus**.

The Series D valve island fieldbus, is a solution dedicated to Industry 4.0 because it is a *SMART* device capable of connecting to other devices or networks (ex. WiFi, USB, NFC) for information exchange. The system can transmit data of the main variables, the diagnostics of all the components of which the island is made. In addition, the system can configure the island and each connected module. The smart interfaces with the system are:

- **Camozzi UVIX** (*Universal Visual Interface*), a software that can be installed on a PC/server/gateway used by USB or included in a company network and accessible from other PCs (cap. 9).



- **NFCamApp** (*NFC Camozzi Application*), smartphone application for Android and iOS (cap. 10).

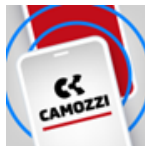

NOTE. In addition, in the Series D Serial valve island configuration, the system has **COILVISION** technology which monitors the correct operation of the coil valve. Each actuation of the coil, in different cyclic configurations and environmental conditions, is analysed to acquire information which, when processed by software algorithms, allows the health of the component to be diagnosed and predicted (par. 6.1.2).

Recipients

The manual is intended exclusively for qualified experts in control and automation technologies who have experience in the installation, commissioning, programming and diagnostics of programmable logic controllers (PLCs) and fieldbus systems.

Installation

5.1 General installation instructions

For reasons of operator safety and to prevent functional damage to the system, before starting any installation or maintenance operation, disconnect:

- The air supply.
- The power supply of the control electronics and outputs/coil valves.

5.2 Connecting and warning components

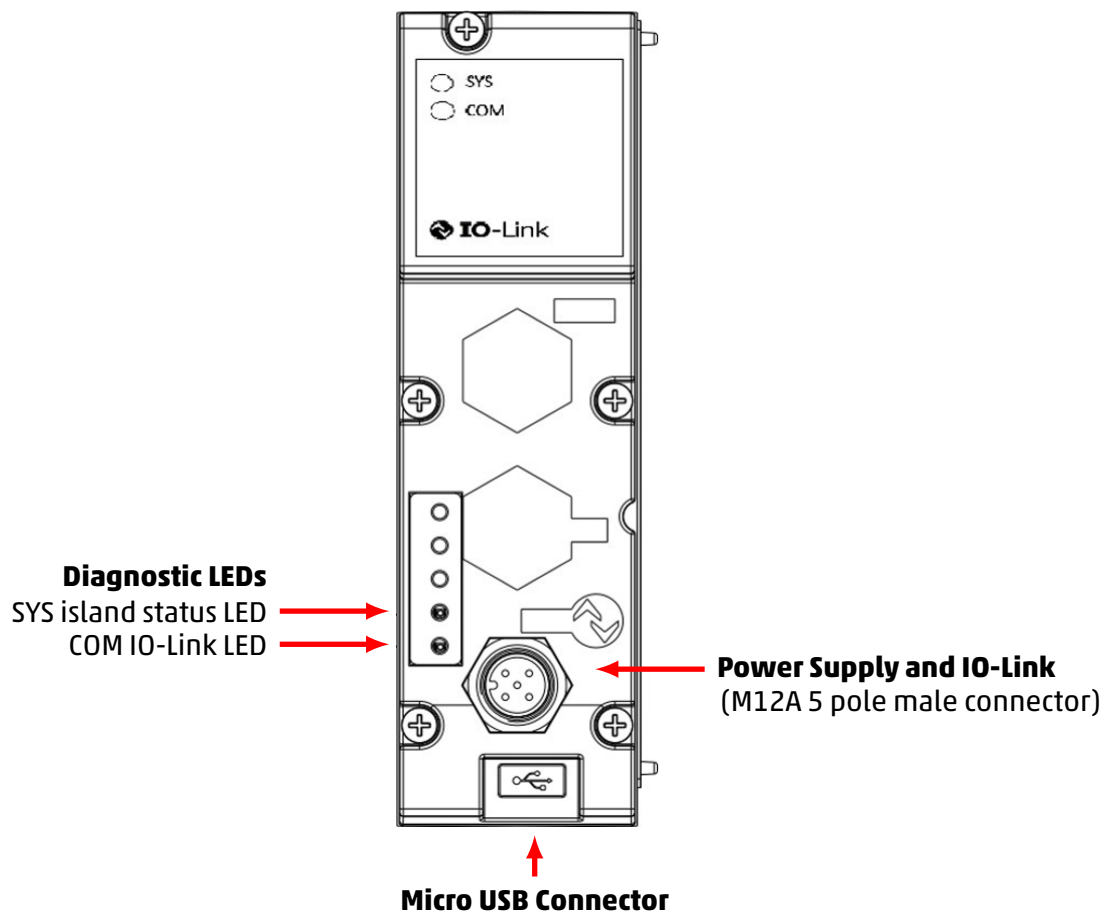

Chapter 5 Installation

5.2.1 Power Supply Connector and IO-Link network

The power supply connector is a 5-pole M12A male.

NOTE. To connect the system to the mains it is recommended to use the connectors from the Camozzi catalogue:

- CS-LF04HB, straight connector to cable.
- CS-LF05HB-D200, straight connector with cable of 2 meters.
- CS-LF05HB-D500, straight connector with cable of 5 meters.

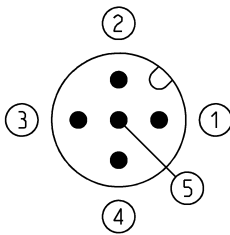
PIN	Signal	Description	Symbol
1	L24V	24 Vdc power supply (logic): connect to the positive pole of the 24 Vdc power supply (referred to GND).	
2	P24V	24 Vdc power supply (power for valves): connect to the positive pole of the 24 Vdc power supply (referred to GND).	
3	GND	Common (pin reference 1): connect to the positive pole of the 24 Vdc power supply (mandatory).	
4	C/Q	IO-Link communication	
5	N24	Common (pin reference 2): connect to the negative pole of the 24 Vdc power supply (mandatory).	

5.2.2 USB Connector

The USB communication connector is a standard micro version. The connector allows the CX4 to be connected to the UVIX interface for monitoring or configuration.

NOTE The dedicated USB connector can be found in the Camozzi catalogue:

- G11W-G12W-2, standard cable with micro-USB connector length 2m.

5.3 Power supply

The power supply is separated into *logic* (L24V), which allows the communication buses and the sub-bases of the pneumatic part, and into *power* (P24V), which powers the valves. Therefore, for the system to work, it is essential to connect the logic power supply, otherwise the CX4 remains off. The two separate power supplies make it possible, if necessary, to disconnect the power supply to the valves while the bus power line remains active. The lack of power supply is signalled by the flashing red SYS island status LED. This problem is also signalled through a message via the network to provide for proper alarm management.

If the loads or inputs connected to the initial node require tighter tolerances of the supply voltage value, the node power supply voltage must respect these.

NOTE. The nominal power supply voltage of the CPU module is 24 Vdc \pm 10%.

5.3.1 Electropilot activation rules

In normal standard operation, the coil valves are activated, for 100 ms, with a power of 1 W (@ 24 V the absorbed current is therefore 41.6 mA). Subsequently, the coil valves are kept activated by reducing the absorbed power to 50% of the initial value, by means of a PWM control technique. The permitted power supply voltage for the series D valve island is 24 Vdc \pm 10%, therefore the useful range is 21.6 Vdc \div 26.4 Vdc. The currents absorbed by the coil valve coils corresponding to the power supply range are 39 mA \div 48 mA (in typical conditions) in the first 100 ms of activation and subsequently 19.5 mA \div 24 mA in the power reduction phase due to the use of PWM. The continuous operation of the valve island is guaranteed for a maximum absorption of 2.5 A. In the worst conditions (maximum current absorption for 26.4 Vdc power supply) it is possible to activate up to 50 coils simultaneously with all the valves of the island off. Subsequently, it is possible to proceed by using the following formula:

$$\text{No. of coils to be controlled simultaneously} = 50 - (0,6 \times \text{No. active coils})$$

Example

- If 10 coils are already active, 44 coils can be activated simultaneously.
- If 20 coils are already active, 38 coils can be activated simultaneously.

NOTE. The maximum number of simultaneously active coils is 80. Each subsequent activation with respect to the previous group of coils must happen after 150 ms.

5.4 Connectable accessories

Series D pneumatic coil valves can be connected to the CX4 module. (par. 6.1).

5.5 Assembly

5.5.1 Dismantling and fitting CX4 module

Dismantle the CX4 module as follows:

1. Switch off the power supply of the CX4 module to avoid problems for the device or user.
2. Loosen the 5 screws.
3. Pull the cover of the CX4 module carefully and without tilting from the manifold base.

Fit the CX4 module as follows:

1. Switch off the operating voltage supply of the CX4 module to avoid problems for the device or user.
2. Make sure that the gaskets are tight and not damaged.
3. Push the cover of the CX4 module carefully and without tilting as far as possible into the manifold base.
4. Tighten the 5 screws (Torque max 0.6 Nm).

NOTE. After an island modification, the mapping procedure is required (par. 7.3).

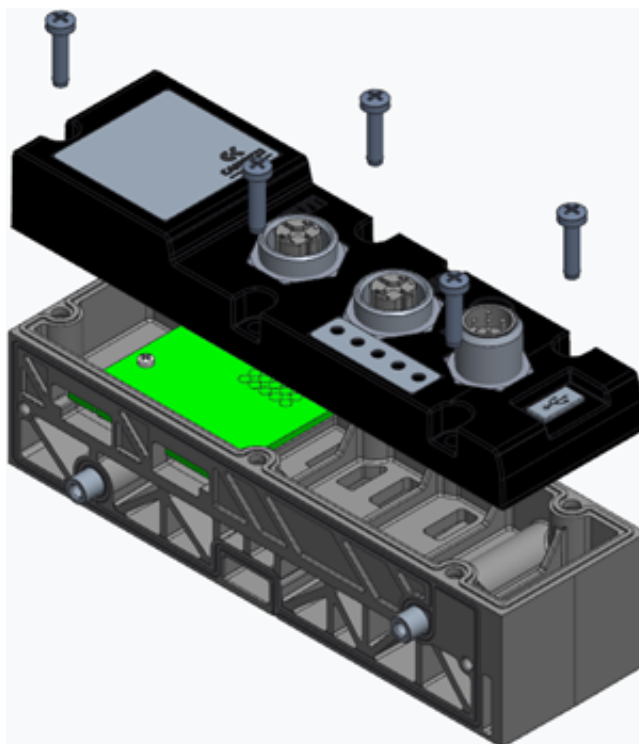

5.5.2 Series D subbases assembly

Dismantle and fit the Series D subbases as follows:

1. Switch off the power supply of the CX4 module to avoid problems for the device or user.
2. Unscrew the 3 screws to the cover at the end of the island and open the valves subbases pack.
3. Remove the valves subbases from the tie-rods and replace with the new modules.
4. Push the valves subbases as far as possible to allow a correct electrical contact.
5. Mount the cover at the end of the island and tighten the 3 screws (Torque max 0.9 Nm)

NOTE. The mapping procedure must be carried out in all those cases in which the valve subbases are added, removed, or moved (par. 7.3).

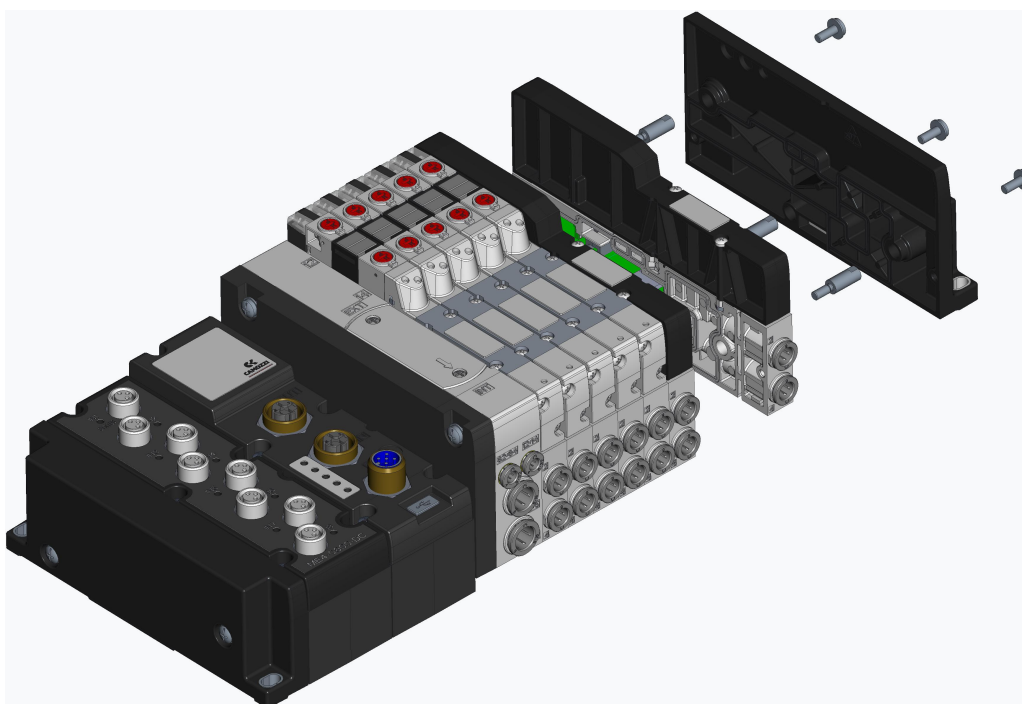

* Example for Series D1 Valve Island.

5.5.3 Dismantling and fitting Serie D coil valves

Dismantle and fit the Serie D coil valves on the same size subbases as follows:

1. Unscrew the 2 screws above the Serie D coil valves.
2. Pull the valves carefully and without tilting from the subbase to avoid damages.
3. Add the new valves carefully and without tilting to the subbase to avoid damages.
4. Tighten the 2 screws (Torque max 0.25 Nm (D1/D5), 0.5 Nm (D2), 2.0 Nm (D4)).
5. Reset the subbase information from UVIX interface or controller/PLC.

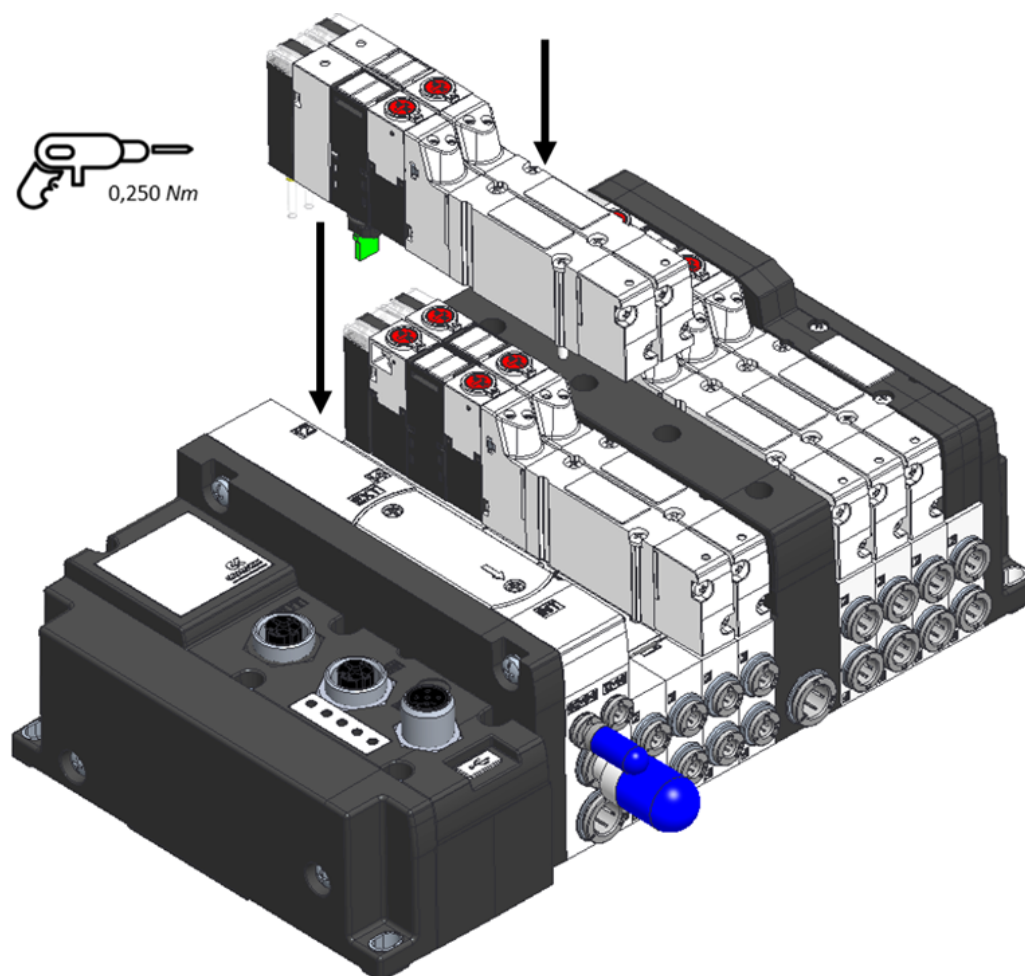

* Example for Series D1 Valve Island.

Accessories

6.1 Series D valve subbase

The CX4 can be used to create a Series D Serial valve island by connecting the subbases on the pneumatic side to allow the new Camozzi Series D coil valves to be connected.

Series D valves are available in three sizes depending on the pitch:

- Series D1 coil valves, 10.5 mm pitch

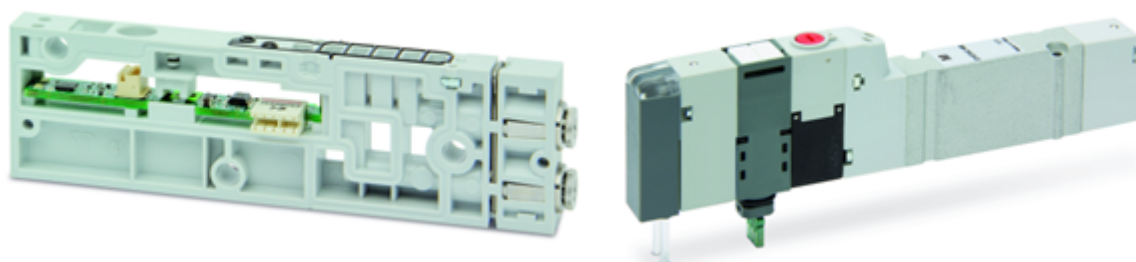

- Series D2 coil valves, 16 mm pitch

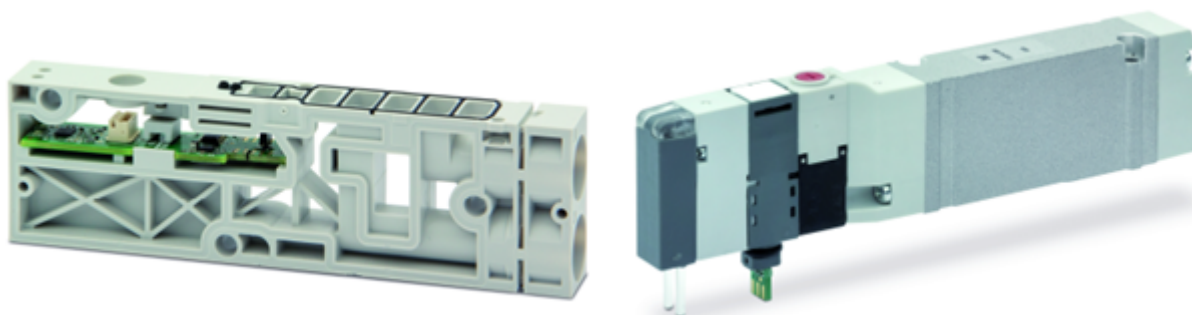

- Series D4 coil valves, 25 mm pitch

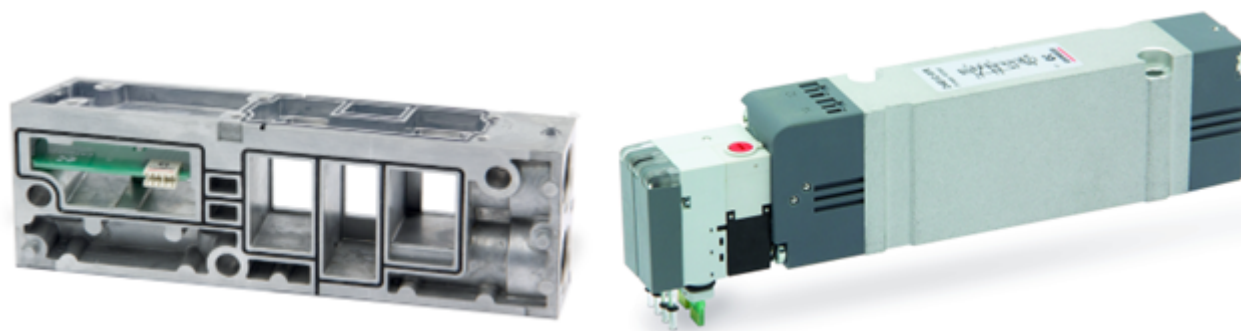

6.1.1 Technical Data

Key feature	Value
Construction	Balanced spool
Valve functions	2x3/2 NC/NO/NC+NO; 5/2; 5/3 CC/CO/CP
Materials	body, spool= AL; bases, end cover = technopolymer; bases = AL only D4; seals = HNBR
Attachments	Variable Bushings Ø (D1-D2-D5) Thread G3/8 (D4)
Ambient temperature	0÷50 °C
Fluid	<ul style="list-style-type: none"> • Compressed air filtered and not lubricated in class 7.4.4 according to ISO 8573-1: 2010. • If lubrication is required, use only oils with max. viscosity. 32 Cst and the version with external servo drive. • The servo drive air quality must be in class 7.4.4 according to ISO 8573-1:2010.
Voltage	24 Vdc
Voltage tolerance	±10%
Absorption	1 W
Insulation class	class F

6.1.2 Coilvision

The subbases of Series D valves are equipped with **COILVISION** technology. This technology was developed to constantly monitor the functional parameters of the coil that drives the spool. Each actuation of the coil, in different cyclic configurations and environmental conditions, is analysed to acquire information which, when processed by software algorithms, allows the health of the component to be diagnosed and predicted.

The information on the health status of the solenoid valve is data supplied by the CX4 module to the PLC and via the UVIX browser interface in the form of a percentage and gauge indicator (par. 9.3.4). Via UVIX, you can also receive a replace solenoid valve warning when its performance has deteriorated (par. 9.3.5). Below is all the information that can be obtained through COILVISION technology.

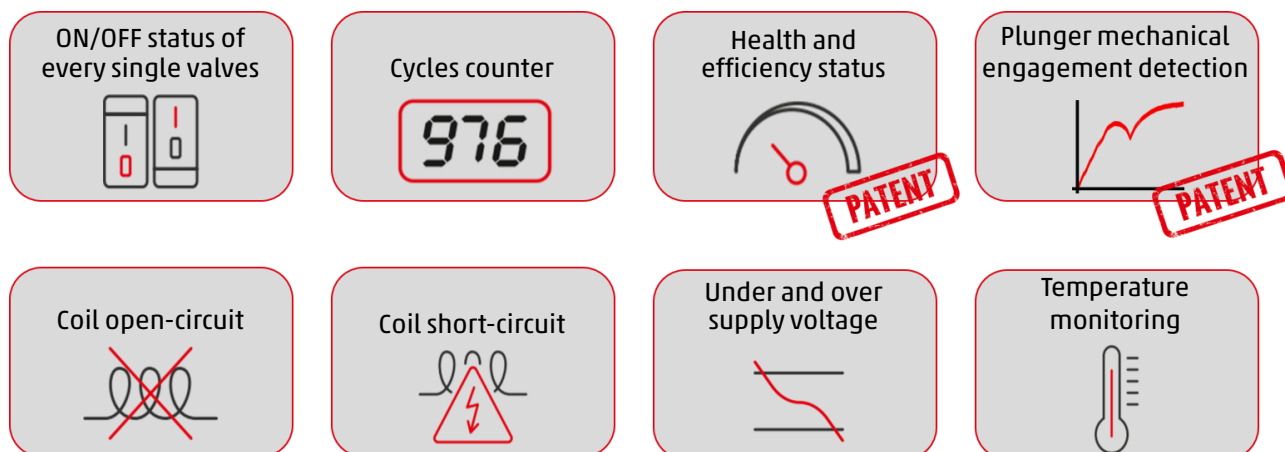

6.1.3 Features

The subbases that control the Series D coil valves can be configured in the management of the failsafe operation and in the management of piloting errors in the coil valves themselves .

Failsafe allows the subbase, in the absence of communication with the CX4 module, to set the status of the commands that drive the coil valves in order to avoid harmful and dangerous situations for devices or users. The parameters that can be configured are the ability to enable failsafe (*Fail Safe Enable*), which is disabled by default, and the state you want to set the valve coils to (*Fail Safe Status*). By default, the coil is off.





Coil management error locking can also be enabled (*Error Enable*). By default it is disabled. If enabled, errors do not simply disappear with the deactivation of the coil but the whole subbase and subsequently the whole system must be restarted.

NOTE. Possible errors on the coils are described in paragraph 6.1. Coil interrupt and coil over-current alarms can be configured as blocking.

6.1.4 Subbase diagnostics

The diagnostics of the subbases for the coil valves are defined by coded flashing of the yellow LED associated with the single coil (the subbase D4 is associated to two yellow LEDs with the same behaviour for each single coil).

Module status and alarms	LED status	Description of the status and solutions of the alarms
Normal operation without alarms	 YELLOW OFF	The valve is not controlled.
	 YELLOW ON	The valve has been operated correctly.

Module status and alarms	LED status	Description of the status and solutions of the alarms
Fault coil	 1 flash YELLOW @100 ms every 1 s	<p>The coil did not energise properly.</p> <p>Solution: the alarm is not blocking, so try operating the coil valve again. If the problem persists, replace the coil valve.</p>
Interrupted coil	 2 flashes YELLOW @100 ms every 1 s	<p>The coil is interrupted or missing. This alarm may be blocking (if configured as such) and therefore the island must be restarted.</p> <p>Solution: replace the coil valve.</p>
Overcurrent coil	 3 flashes YELLOW @100 ms every 1 s	<p>The current consumption of the coil is excessive and therefore the coil valve is automatically switched off.</p> <p>Solution: replace the coil valve.</p>
Overheating coil	 3 flashes YELLOW @100 ms every 1 s	<p>The coil temperature is too high. This alarm may be blocking (if configured as such) and therefore the island must be restarted.</p> <p>Solution: remove the ON control on the coil valve and allow the coil to cool down. If the problem persists, replace the coil valve.</p>
Overheating subbase	 5 flashes YELLOW @100 ms every 1	<p>The subbase electronics temperature is too high.</p> <p>Solution: switch off the island and let the device cool down. If the problem persists, contact support, and replace the subbase.</p>

NOTE. The interrupted coil and overcurrent alarms can block operation (configurable feature) and can only be reset by restarting the entire system.

Commissioning

7.1 Electrical connections

It is recommended to check that the IO-Link master used is class B and able to supply the necessary current, and to use a suitable cable according to the IO-Link standard.

7.2 Start-up operation

The CX4 module performs a system-wide configuration check at start-up. This is called *mapping*. Specifically, the system configuration is determined by the type and position of the coil valve subbases. The system mapping is saved in the CX4 module's internal memory. If the mapping has never been stored or the configuration of the system has been modified, a new mapping request must be made (par. 7.3). During the mapping operation, the general diagnostic LEDs of the sub-bases of solenoid valves turn on in sequence.

- If the mapping finishes successfully, the CX4 moves on to the next stage. Furthermore, the diagnostic LEDs of each recognized module are switched off.
- If the mapping is not completed correctly, a diagnostic alarm will be triggered (par. 8.1.2) and the CX4 module will not proceed with any other operations.

7.3 Mapping

The Series D Valve Island Fieldbus is extremely flexible and its configuration can be modified by removing, replacing or changing the positions of the coil valve subbases. Each time a change is made, the mapping procedure must be carried out to correctly configure the entire system. The CX4 module must be aware of the composition of the entire island: number, type and location of coil valve subbases.

The mapping operation can be performed with the use of software, by sending a request for new mapping, without having to physically work with the island. A new mapping can be requested in the following ways:

- Camozzi UVIX as Gateway-USB (par. 9.4).
- NFCamApp, smartphone app (par. 10.5).
- Command from IO-Link: The command can also be sent via protocol using acyclic data implemented for this purpose. Please refer to the CX4 IO-Link module acyclic data chapter for more information on the data used for this purpose. Sending the command may cause a temporary drop in IO-Link communication; as the procedure must only be carried out when commissioning the machine, the drop in connection does not entail any risk.

NOTE. Once the mapping request has been made, the CX4 module must be restarted.

7.4 Versions

In order to optimise the exchange dimensions, Series D serial IO-Link are divided into three versions according to the number of valve positions present.

- 12-valve version with 12 or fewer valve positions.
- 24-valve version with more than 12 and less than or equal to 24 valve positions.
- 32-valve version with more than 24 and less than or equal to 32 valve positions.

7.5 Configurazione tramite file IODD

The IODD file is not essential for commissioning the device but is useful for its configuration. Manufacturers of IO-Link masters usually provide software for configuring the devices connected to it, which can be run internally or externally to the PLC development environment.

Once the software has been run, it is possible to import the IODD and configure the island more easily. For more information on the software please refer to the manufacturer of the IO-Link master used.

The IODD file can be found on the Camozzi website at:

<http://catalogue.camozzi.com/Downloads>

7.6 Addressing

The IO-Link protocol is point-to-point and as such does not need to be configured for addressing.

The only parameter that is required by the master is the size of the cyclic data (Process Data or PD in IO-Link technical documentation). To find out the size of the cyclic data, first identify the correct version you are using, then check the number of valve positions on the island, after which:

Chapter 7 Commissioning

- 12-valve version = 3 input PD + 3 output PD.
- 24-valve version = 6 input PD + 6 output PD.
- 32-valve version = 8 input PD + 8 output PD.

7.6.1 Mappatura degli elettropiloti

It may happen that the order of the cyclic data differs from what is expected, i.e. the first bit of the first byte does not drive the first coil. This behaviour is affected by how the PLC manages the data and how it has been programmed. Considering the 32-valve version, the space occupied is equal to 8 bytes, let's assume they are mapped to the PLC outputs from Q0 to Q7. If you manage the bytes individually, the order will be reversed.

PLC Outputs	Driven valve positions
Q0	29...32
Q1	25...28
Q2	21...24
Q3	17...20
Q4	13...16
Q5	9...12
Q6	5...8
Q7	1...4

If you manage a variable with a size of 8 bytes (LWORD), where with B0 you drive the first four valves and with B7 the last four.

LWORD							
B7	B6	B5	B4	B3	B2	B1	B0

At the moment you will map the memorized variable based on how the PLC manages the data, two situations can occur.

	Q0	Q1	Q2	Q3	Q4	Q5	Q6	Q7
Big Endian	B7	B6	B5	B4	B3	B2	B1	B0
Little Endian	B0	B1	B2	B3	B4	B5	B6	B7

Chapter 7 Commissioning

So, if the PLC manages the Little *little endian*, you will have the reverse order again, if they are managed by *big endian*, they will be in the right order. Following the same logic, it is possible to obtain the position of the bits, referred to the coils that you want to drive, with any combination of address space and defined variables. Through the dedicated parameter it is possible to enable an internal function of the CX4 that makes a byte inversion. Therefore, in case of byte inversion you only need to change the value of this parameter to return to a more convenient situation, for further details on the parameter, please consult the dedicated chapter.

7.7 Address assignment

The address capacity of the Series D valve island in the IO-Link network is assigned by the data exchanged cyclically between the island and the IO-Link master (and consequently with the PLC); depending on the island version used, the capacity is fixed.

Version	Maximum number of coils	Input bytes	Output bytes
12 valves	24	3	3
24 valves	48	6	6
32 valves	64	8	8

Each valve position occupies 2 bits (one for each coil) regardless of whether the mounted valve is monostable, bistable or a free position. Therefore:

- Bit 0: First valve, coil 14.
- Bit 1: First valve, coil 12.
- Bit 2: First valve, coil 14.
- Bit 3: First valve, coil 12.
- ...

This configuration is valid for both input data and output data.

7.8 Exchange data

As defined by the IO-Link protocol, there are three types of data exchanged between device and master:

- Process data: data exchanged cyclically.
 - PDIN (Process Data Input): the cyclic input data means data from the valve island to the IO-Link master and contains the general status of the coil. Each bit indicates, by means of COIL-VISION technology, whether the relevant coil is working properly (value 0) or is unable to guarantee performance and should be replaced (value 1).
 - PDOUT (Process Data Output): the cyclical output data is the data from the IO-Link master to the valve island and contains the status that the relevant coil should assume. Coil ON (value 1) or coil OFF (value 0).
 - *On-request data (OD)*: data exchanged only on request, usually the configuration parameters and the coils commands.
 - *Events*: events generated by the device, typically containing diagnostic information.
-

Nomenclature

As defined by the IO-Link protocol, each parameter is identified by an index and a sub-index. In the case of a group of parameters with the same index and different sub-indexes, it is always possible to access the entire group via their index and with a sub-index of 0.

Each parameter has its own access rule:

- *Read-Only (RO)*
 - *Read-Write (RW)*
 - *Write-Only (WO): generally used to implement commands.*
-

7.8.1 Parameterisation

7.8.1.1 Modulo CX4 IO-Link

The *System Start* allows the CX4 head to work in two alternative modes: if left at the default value (0), all the application parameters described in the following paragraphs, although still transmitted, are ignored by the CX4 module software, which instead will apply the values already stored in its own non-volatile memory; this is because a CX4 module can normally be configured not only with a PLC, but also using UVIX, and because of this we wanted to add the option not to overwrite any pre-existing configuration. If, on the other hand, this parameter is set to 1, any parameterization carried out on the master tool will be applied by the head software at the end of the boot phase.

Parameter	Index (DEC)	Sub-index (DEC)	N° bytes	Access	Unit	Description
Vendor Name	16	0	Max 64	RO	-	Builder name
Vendor Text	17	0	Max 64	RO	-	Builder additional information
Product Name	18	0	Max 64	RO	-	Product name
Product ID	19	0	Max 64	RO	-	Product identifier
Product Text	20	0	Max 64	RO	-	Product description
Serial Number	21	0	Max 64	RO	-	Device unique serial number
Hardware Version	22	0	Max 64	RO	-	Hardware version
Firmware Version	23	0	Max 64	RO	-	Firmware version
Application Specific Tag	24	0	Da 16 a 32	RW	-	Parameter for user application
Temperature	256	0	4	RO	°C	Module temperature
Supply voltage	257	0	2	RO	V	Additional power supply

Chapter 7 Commissioning

Logic voltage	258	0	2	RO	V	Logic power supply
Mapping Forced	259	0	1	WO	-	Command to start the mapping procedure
Device Access Locks.Local Parameterization Lock	12	0	2	RW	-	Allows parameterisation from UVIX to be blocked. Setting the third bit of the first byte to 1 blocks parameterisation by UVIX, 0 to allow it.
Process data swap	400	0	1	RW	-	Allows to invert the cyclic data. Setting it to 1 they are inverted compared to the default configuration

7.8.1.2 Series D valve sub-bases

Reset valve parameters

It is possible to reset valve parameters to default values through the following commands.

Parameter	Index (DEC)	Sub-index (DEC)	N° bytes	Access	Version
Reset the valve 1 parameters to defaults	260	0	1	WO	12/24/32
Reset the valve 2 parameters to defaults	261				
Reset the valve 3 parameters to defaults	262				
Reset the valve 4 parameters to defaults	263				
Reset the valve 5 parameters to defaults	264				
Reset the valve 6 parameters to defaults	265				
Reset the valve 7 parameters to defaults	266				
Reset the valve 8 parameters to defaults	267				
Reset the valve 9 parameters to defaults	268				
Reset the valve 10 parameters to defaults	269				
Reset the valve 11 parameters to defaults	270				
Reset the valve 12 parameters to defaults	271				
Reset the valve 13 parameters to defaults	272				24/32
Reset the valve 14 parameters to defaults	273				
Reset the valve 15 parameters to defaults	274				
Reset the valve 16 parameters to defaults	275				
Reset the valve 17 parameters to defaults	276				
Reset the valve 18 parameters to defaults	277				
Reset the valve 19 parameters to defaults	278				
Reset the valve 20 parameters to defaults	279				
Reset the valve 21 parameters to defaults	280				
Reset the valve 22 parameters to defaults	281				
Reset the valve 23 parameters to defaults	282				
Reset the valve 24 parameters to defaults	283				
Reset the valve 25 parameters to defaults	284				
Reset the valve 26 parameters to defaults	285				
Reset the valve 27 parameters to defaults	286				
Reset the valve 28 parameters to defaults	287				
Reset the valve 29 parameters to defaults	288				
Reset the valve 30 parameters to defaults	289				
Reset the valve 31 parameters to defaults	290				
Reset the valve 32 parameters to defaults	291				

Chapter 7 Commissioning

Reset diagnostic data

Following the replacement of a valve, it is necessary to reset the diagnostic data stored in the sub-base using the following commands.

NOTE. This operation can be performed by sending the command from UVIX (par. 9.3.6).

Parameter	Index (DEC)	Sub-index (DEC)	N° bytes	Access	Version
Reset the valve 1 information	292	0	1	WO	12/24/32
Reset the valve 2 information	293				
Reset the valve 3 information	294				
Reset the valve 4 information	295				
Reset the valve 5 information	296				
Reset the valve 6 information	297				
Reset the valve 7 information	298				
Reset the valve 8 information	299				
Reset the valve 9 information	300				
Reset the valve 10 information	301				
Reset the valve 11 information	302				
Reset the valve 12 information	303				
Reset the valve 13 information	304				24/32
Reset the valve 14 information	305				
Reset the valve 15 information	306				
Reset the valve 16 information	307				
Reset the valve 17 information	308				
Reset the valve 18 information	309				
Reset the valve 19 information	310				
Reset the valve 20 information	311				
Reset the valve 21 information	312				
Reset the valve 22 information	313				
Reset the valve 23 information	314				
Reset the valve 24 information	315				
Reset the valve 25 information	316				
Reset the valve 26 information	317				
Reset the valve 27 information	318				
Reset the valve 28 information	319				
Reset the valve 29 information	320				
Reset the valve 30 information	321				
Reset the valve 31 information	322				
Reset the valve 32 information	323				

Chapter 7 Commissioning

Valve information

Single valve information: each valve has a group of parameters read only and with the same index with all the information for that valve. The indexes according to the valve to which it refers are the following.

Valve position	Index (DEC)	Version
1	324	12/24/32
2	326	
3	328	
4	330	
5	332	
6	334	
7	336	
8	338	
9	340	
10	342	
11	344	
12	346	
13	348	24/32
14	350	
15	352	
16	354	
17	356	
18	358	
19	360	
20	362	
21	364	
22	366	
23	368	
24	370	
25	372	32
26	374	
27	376	
28	378	
29	380	
30	382	
31	384	
32	386	

Chapter 7 Commissioning

Each index related to the individual valve contains the following variables.

Parameter	Sub-index (DEC)	N° bytes	Unit	Description
Firmware version	1	7	-	Firmware version of the sub-base
Subbase temperature	2	2	°C	Sub-base temperature
Cycles coil 14	3	4	-	Number of cycles of coil 14
Cycles coil 12	4	4	-	Number of cycles of coil 12
Health status coil 14	5	1	%	Health status of coil 14
Health status coil 12	6	1	%	Health status of coil 12
Temperature coil 14	7	2	°C	Temperature of coil 14
Temperature coil 12	8	2	°C	Temperature of coil 12
Communication retries	9	2	-	Number of errors on internal communication between valve position and CX4 IO-Link module
Errors coil 14	10	4	-	Number of errors of coil 14
Errors coil 12	11	4	-	Number of errors of coil 12

Chapter 7 Commissioning

Valve parameters

Each valve has a set of read and write parameters that allow the parameterisation of the valve to which they refer. The indexes according to the valve to which it refers are as follows.

Valve position	Index (DEC)	Version
1	325	12/24/32
2	327	
3	329	
4	331	
5	333	
6	335	
7	337	
8	339	
9	341	
10	343	
11	345	
12	347	
13	349	24/32
14	351	
15	353	
16	355	
17	357	
18	359	
19	361	
20	363	
21	365	
22	367	
26	369	
24	371	
25	373	32
26	375	
27	377	
28	379	
29	381	
30	383	
31	385	
32	387	

Chapter 7 Commissioning

Each index related to the individual valve contains the following parameters.

Parameter	Sub-index (DEC)	N° bytes	Unit	Description
Failsafe enable 14	1	1	0 = Disabilitato 1 = Abilitato	Enabling the failsafe function of coil 14
Failsafe enable 12	2		0 = Disabilitato 1 = Abilitato	Enabling the failsafe function of coil 12
Failsafe status 14	3		0 = OFF 1 = ON	State to which coil 14 should be brought in the event of failsafe activation
Failsafe status 12	4		0 = OFF 1 = ON	State to which coil 12 should be brought in the event of failsafe activation
Alarm mode	5		0 = Temporaneo 1 = Bloccante	Indicates the error behaviour that can arise from the activation of a coil. Once the error occurs if this parameter is set to Blocker the error will remain present until the island is restarted, if set to Temporary the error will disappear when the coil receives an OFF command.

Valve diagnostic

The errors that can be generated in a valve position and reported by the system diagnostics (par. 6.1.4) do not indicate which element or elements have generated them. A group of parameters has been implemented for each error that could be generated: each group consisting of a parameter for each valve position indicating the status for that error. Each group of parameters shares a common index, differs by sub-index and varies in number depending on the version (12 for the 12-valve version, 24 for the 24-valve version and 32 for the 32-valve version). The sub-indexes start at 1 for the first valve position, 2 for the second and continue up to 12, 24 or 32 depending on the version. Each parameter has a size of 1 byte, is read-only and can be worth "0" if the error is not present or "1" if present.

The indexes of the various parameters are as follows.

Parameter	Index (DEC)	Description
Over heating subbase	388	Overheated valve position
Communication alarm	389	Valve position communication error
Configuration alarm	390	Valve position configuration error
Valve substitute	391	At least one of the two coils in the indicated valve position has not degenerated and is no longer able to guarantee its performance
Interrupted coil 14	392	Coil 14 is interrupted
Interrupted coil 12	393	Coil 12 is interrupted
Fault coil 14	394	Coil 14 has not engaged
Fault coil 12	395	Coil 12 has not engaged
Over heating coil 14	396	Coil 14 has overheated
Over heating coil 12	397	Coil 12 has overheated
Over current coil 14	398	Coil 14 has excessive current consumption
Over current coil 12	399	Coil 12 has excessive current consumption

Protocol parameters

The protocol provides two parameters to identify the status of the island and a list of active errors and / or warnings.

Parameter	Index (DEC)	Access	N° Bytes	Description
Device Status	36	RO	1	Indicates the status of the island: <ul style="list-style-type: none"> 0: the device works properly 1: Maintenance required, at least one coil has a low health status 2: Out of specification, the device has at least one error or warning
Detailed Device Status	37		List of 64 elements, 3 bytes per element	The first byte of each element contains the <i>EventQualifier</i> and the other two the event code.

The *Detailed Device Status* parameter is a list of 64 elements, the first byte of each element contains a data defined by the protocol called *EventQualifier* while the other two contain the event code (par. 8.1.2). The *EventQualifier* is defined as follows:

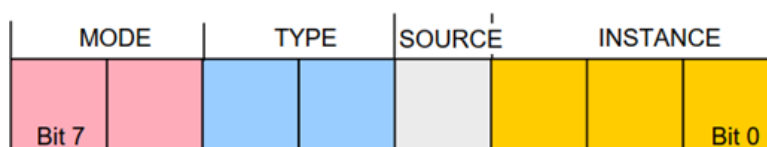

- *Instance* (bit da 0 a 2): contains the source of the event, in this case it will always have the value 4.
- *Source* (bit 3): indicates which device generates the event, in this case it will always have the value 0.
- *Type* (bit 4 e 5): indicates the type of event, in this case it can assume the value 2 in the event of a warning or 3 in the event of an error.
- *Mode* (bit 6 e 7): indicates the mode, i.e. if it appears or disappears, in this case only the events present appear in the list and will therefore always have the value 3.

7.9 Data Storage

Data Storage is a function of the IO-Link protocol. By enabling it, the master stores the parameterisation of the device. Each time it is switched on, the master compares the parameterisation of the device with the one it has saved and checks whether there is a request from the device to save a new configuration. The main situations that could occur are:

- The device was parameterised before commissioning: when connected to the master, the device warns it to save its parameterisation.
- The device must be replaced: when connecting to the master, the master realises that the parameterisation of the new device is different from the one saved and therefore sets new parameters.

Depending on the master used, there may be additional features. For an overview of all features and how to perform them, please refer to the IO-Link master manual.

7.10 Local parameterisation



Local parameterisation is a feature of IO-Link that manages parameterisation from sources outside the protocol. The IO-Link master manages changes from UVIX through the parameter *Device Access Locks.Local Parameterization Lock*.

NOTE. As can be seen, priority remains with the IO-Link master, which has the power to decide whether or not to allow UVIX to parameterise the CX4.

Diagnostic

The diagnostics of the CX4 IO-Link module is defined in three different ways.

- The status of the LEDs on the CX4 or on the individual modules connected to it **6**. The following table provides the typical behaviour of the LEDs on our modules. The colour of the LEDs can be different for each module (the table refers to a red LED).

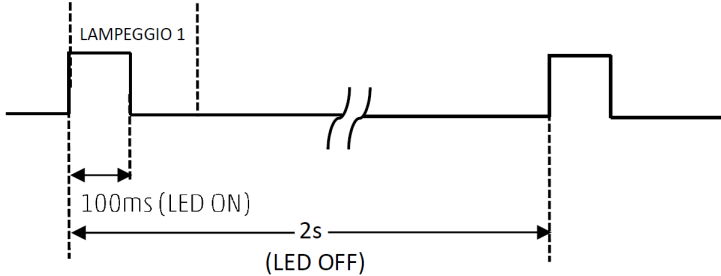
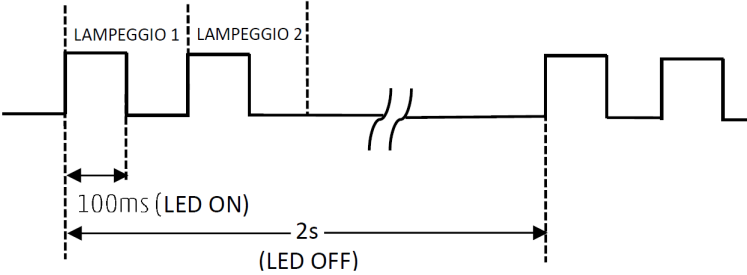
Symbol	LED state	Description
	RED OFF	Led is OFF
	RED ON	Led is ON
	FLASHING	<p>The led flashes with a specified sequence for each diagnostic state: @XX [ms/Hz] per YY [s]</p> <ul style="list-style-type: none"> • XX is the ON time of a led flashing. The flashing sequence is represented by an ON state and an OFF state of the same time. • YY is the time of the repeated flashing sequence. <p>Example 1: 1 flash @100 ms every 2 s</p>  <p>Example 2: 2 flashes @100 ms every 2 s</p> 

Chapter 8 Diagnostic

- The events of the IO-Link protocol: the CX4 IO-Link module sends diagnostic messages to the master to which it is connected; in the case of the IO-Link protocol, these messages are called events and are identified by a unique code. Once the event code arrives at the IO-Link master, it will be up to the master to send it to the PLC using the communication protocol used. For more details refer to the IO-Link master manufacturer's manual.
- The PQI of the IO-Link protocol: is a byte provided for by the IO-Link protocol and which the master sends cyclically to the PLC.





- Bit 0 to 4: Reserved for future use.
 - Bit 5 *DevCom*: set if the device has been detected and is in preoperate or operate status.
 - Bit 6 *DevErr*: set if the device is in error or warning.
 - Bit 7 *PQ (Port Qualifier)*: set if the cyclic data are valid.
- The UVIX user interface (ch. 9)

8.1 CX4 module







8.1.1 IO-Link node

The behaviour of the COM LED is defined by the protocol as follows.

LED	Operation	Description
COM	 LED OFF	No IO-Link communication/device not in Operate state
	 1 Flash GREEN @900 ms every 1s	IO-Link communication present/device in Operate state

8.1.2 CX4 system diagnostics

The diagnostics of the CX4 system is managed by the SYS diagnostic LED, by the events generated to the protocol IO-Link and by the display on the UVIX interface.

Module status and alarms	SYS LED	Event Code (DEC)	UVIX
Normal operation	 1 flash GREEN @100 ms every 1 s		
Valves absent	 1 flash GREEN @100 ms every 1 s	6144	Valves absent
Valves substitution	 1 flash GREEN @100 ms every 1 s	6152	Valve Subbase Substitution
Overheating CX4 module	 RED ON	6147	Overheating CX4 module
Undervoltage CX4 module	 RED ON	6148	Undervoltage CX4 module
Alarm of mapping valves error	 2 flashes RED @100 ms every 1 s	6145	Mapping valves error

8.1.3 Replace solenoid valve

This *warning* indicates that the optimal performance of at least one solenoid valve has deteriorated and is no longer guaranteed.

Solution: replace the deteriorated solenoid valve.

NOTE. To find out which solenoid valves on the island are in these conditions, you need to connect to the Camozzi user interface (UVIX) and check the health status of the individual solenoid valves (par. 9.3.4).

8.1.4 Over-temperature alarm

The CX4 module has reached or exceeded the limit temperature over which the normal operation of the device is not guaranteed and, if the condition persists, this can lead to the failure of a component on the board.

Solution: restart the island; if the problem persists, contact Camozzi support.

8.1.5 Undervoltage alarm

The CX4 module is powered with a voltage lower than the minimum acceptable value; therefore, correct operation of the system is not guaranteed.

Solution: check that the wiring is correct and that the wires are properly inserted into the connector. Check that the logic supply (pins 1 and 3) and power supply (pins 2 and 5) are physically present on the connector. If the problem persists, contact Camozzi support.

8.1.6 Solenoid valve mapping error

During the mapping phase (par. 7.3), a solenoid valve error has occurred on the subbase. The mapping has failed at the first subbase with the diagnostic LED off.

Solution: repeat the mapping procedure and replace where necessary the subbase where the mapping ends (first subbase with diagnostic LED off). If the problem persists, contact Camozzi support.

8.1.7 No mapping

After requesting a new system mapping (par. 7.3), an error has occurred and the mapping ends at the first subbase with the diagnostic LED off.

Solution: repeat the mapping procedure and replace where necessary the subbase where the mapping ends (first subbase with diagnostic LED off). If the problem persists, contact Camozzi support.

8.1.8 Solenoid valve

These alarms are specific for each individual accessory module. The UVIX and IO-Link messages are specified in the following tables, while the diagnostics via LEDs - found on each individual module - and the specific solutions are detailed in the accessories section (ch. 6).

8.2 Series D valve subbases

The following table shows the diagnostic status of the Series D coil valves, with the respective IO-Link messages and the display on the UVIX interface. The coil valves display a diagnostic signal through LED signalling directly on the subbase where they are mounted. For details regarding LED diagnostics and possible solutions to any alarms, refer to the Accessories chapter (par. 6.1.4).

Module status and alarms	Event code (DEC)	Event type	UVIX
Configuration	6146	Warning	
Subbase Over Heating	6149	Error	Overheating subbase
Over Heating coil (Position 14)	6157		Overheating coil 14
Over Heating coil (Position 12)	6158		Overheating coil 12
Over Current coil (Position 14)	6159		Overcurrent coil 14
Over Current coil (Position 12)	6160		Overcurrent coil 12
Interrupted coil (Position 14)	6153		Interrupted coil 14
Interrupted coil (Position 12)	6154		Interrupted coil 12
Fault coil (Position 14)	6155		Fault coil 14
Fault coil (Position 12)	6156		Fault coil 12
Communication alarm	6150		Communication alarm

Uvix

9.1 Introduction

Camozzi's proprietary environment, called UVIX, allows the user to monitor and configure all new generation Camozzi devices (*Camozzi Smart Devices*) that support connection to it. Devices can be connected to UVIX in two ways: wireless or USB. This system has been implemented with a *web-based* architecture so that information can be accessed straightforwardly using a browser.

Monitoring consists of displaying all the device variables, whether they relate to operation, diagnostics, or parameterization.

For details on the UVIX architecture, its installation, and general operations, see the [Manuale UVIX](#).

9.2 General information

The devices connected to the UVIX are displayed in a tree diagram **1** consisting of *Device Groups*, *Family* e *Devices*. Select one of the components to view in the main window **2** all the information on the various devices and perform configuration operations or manual commands.

By selecting the Series D valve island or Series D coil valve subbases, general status information and details can be displayed. These are divided into variables, alarms and controls.

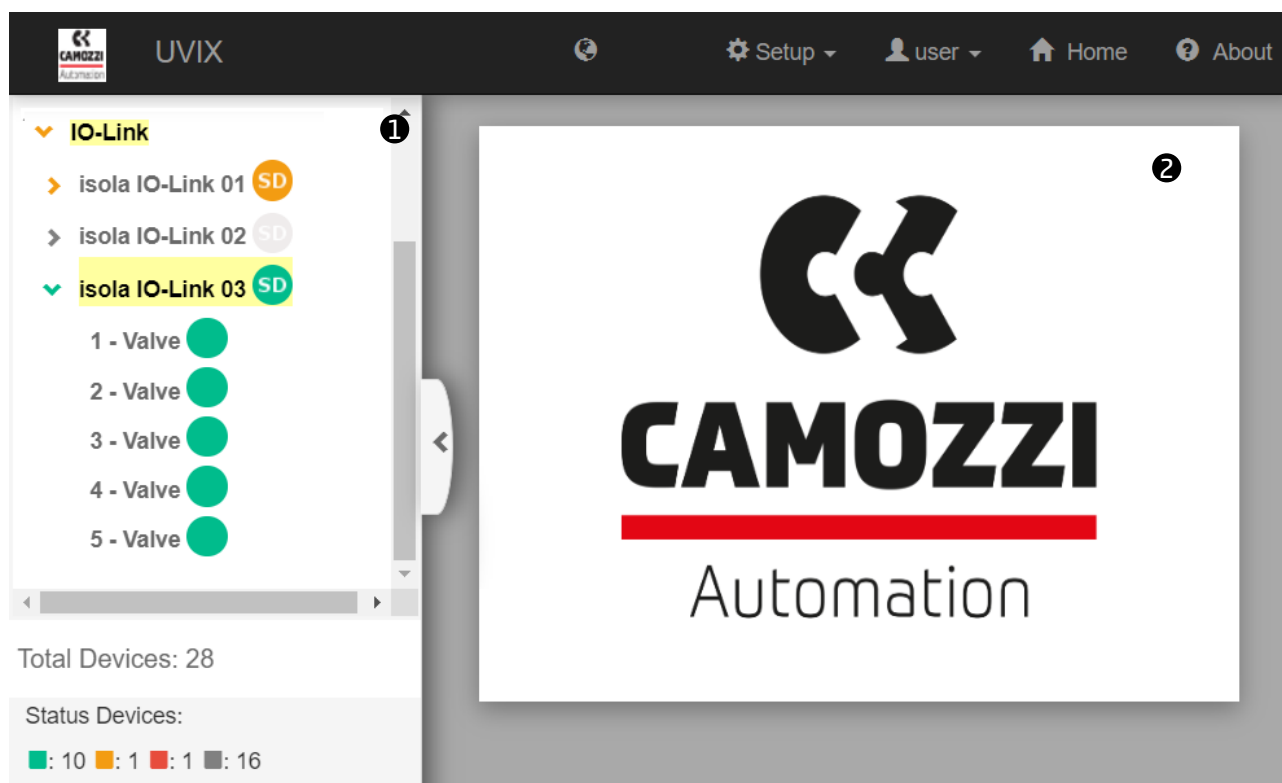

9.2.1 Status information

Select a Series CX4 module to view the main information.

- ① Series CX4 identification image..
- ② Device name, assigned when recognized and added in UVIX.
- ③ Device identification number (17 characters).
- ④ Device family name: *Series CX4*.
- ⑤ Type of *Series D Fieldbus* according to the connected accessory modules:
 - *D1* with at least one Series D1 solenoid valve connected.
 - *D2* with at least one Series D2 solenoid valve connected.
 - *D4* with at least one Series D4 solenoid valve connected.
 - *D5* with at least one Series D1 and one Series D2 solenoid connected.
- ⑥ Firmware version.
- ⑦ Date and time of the last transmission between CX4 module and UVIX.
- ⑧ General status of the module: ● *Not available*, ● *Ok*, ● *Alarm*.
- ⑨ Stato operativo del modulo:
 - *Init* → initialization of the CX4 module and accessory modules.
 - *Enumeration* → numbering of the accessory modules connected to the CX4 module (required if modules are replaced or moved with respect to the original configuration).
 - *Mapping* → mapping of the accessory modules connected to the CX module (required to check that there have been no changes since the last system configuration).
 - *Work* → normal operation.
 - *Manual* → manual operation.
 - *Configuration* → configuration of the parameters of the CX4 module and the accessory modules.
 - *Fatal error* → fatal error that renders the CX4 module inoperative.
- ⑩ WiFi connection status: ● *Online*, ● *Offline*.
- ⑪ Fieldbus used by the module: IO-Link.
- ⑫ Fieldbus communication status: ● *Online*, ● *Offline*.
- ⑬ Configuration of fieldbus-related parameters.

Status information: ▼

<div style="border: 1px solid green; padding: 5px; width: 60px; height: 60px; margin: 0 auto;"> <div style="text-align: center; font-weight: bold; font-size: 1.2em;">①</div>  </div>	<div style="border-bottom: 1px solid #ccc; padding: 2px 0;"> <div style="display: flex; align-items: center;"> <div style="font-weight: bold; font-size: 1.2em; margin-right: 5px;">②</div> <div>Name: isola IO-Link 03</div> </div> </div> <div style="border-bottom: 1px solid #ccc; padding: 2px 0;"> <div style="display: flex; align-items: center;"> <div style="font-weight: bold; font-size: 1.2em; margin-right: 5px;">③</div> <div>Device number: 01302106990000001</div> </div> </div> <div style="border-bottom: 1px solid #ccc; padding: 2px 0;"> <div style="display: flex; align-items: center;"> <div style="font-weight: bold; font-size: 1.2em; margin-right: 5px;">④</div> <div>Family name: Series CX4</div> </div> </div> <div style="border-bottom: 1px solid #ccc; padding: 2px 0;"> <div style="display: flex; align-items: center;"> <div style="font-weight: bold; font-size: 1.2em; margin-right: 5px;">⑤</div> <div>Subtype: Series D Fieldbus - D1</div> </div> </div> <div style="border-bottom: 1px solid #ccc; padding: 2px 0;"> <div style="display: flex; align-items: center;"> <div style="font-weight: bold; font-size: 1.2em; margin-right: 5px;">⑥</div> <div>Firmware: 1.11</div> </div> </div>	<div style="border-bottom: 1px solid #ccc; padding: 2px 0;"> <div style="display: flex; align-items: center;"> <div style="font-weight: bold; font-size: 1.2em; margin-right: 5px;">⑦</div> <div>Last data transmission: 2022-10-03 11:57:34</div> </div> </div> <div style="border-bottom: 1px solid #ccc; padding: 2px 0;"> <div style="display: flex; align-items: center;"> <div style="font-weight: bold; font-size: 1.2em; margin-right: 5px;">⑧</div> <div>Device status: ●</div> </div> </div> <div style="border-bottom: 1px solid #ccc; padding: 2px 0;"> <div style="display: flex; align-items: center;"> <div style="font-weight: bold; font-size: 1.2em; margin-right: 5px;">⑨</div> <div>Operational status: Work</div> </div> </div> <div style="border-bottom: 1px solid #ccc; padding: 2px 0;"> <div style="display: flex; align-items: center;"> <div style="font-weight: bold; font-size: 1.2em; margin-right: 5px;">⑩</div> <div>Connection: ●</div> </div> </div>
<div style="display: flex; justify-content: space-between; align-items: center;"> <div style="font-weight: bold; font-size: 1.2em;">⑪</div> <div>FieldBus: IO-LINK</div> <div style="font-weight: bold; font-size: 1.2em;">⑫</div> <div>Link status: ●</div> <div style="font-weight: bold; font-size: 1.2em;">⑬</div> </div>		

9.2.2 Variables

The first tab of the details page deals shows the variables that are monitored by the CX4 module.

- ❶ Internal temperature of the module.
- ❷ Power voltage that supplies the subbases of the solenoid valves: the measurement is made by the first subbase connected (position 1) and is sent via serial communication. If there are no valves connected, this voltage is not displayed.
- ❸ Logic voltage that powers the module circuit board. Without this supply voltage, the entire system is without power and, therefore, turned off.

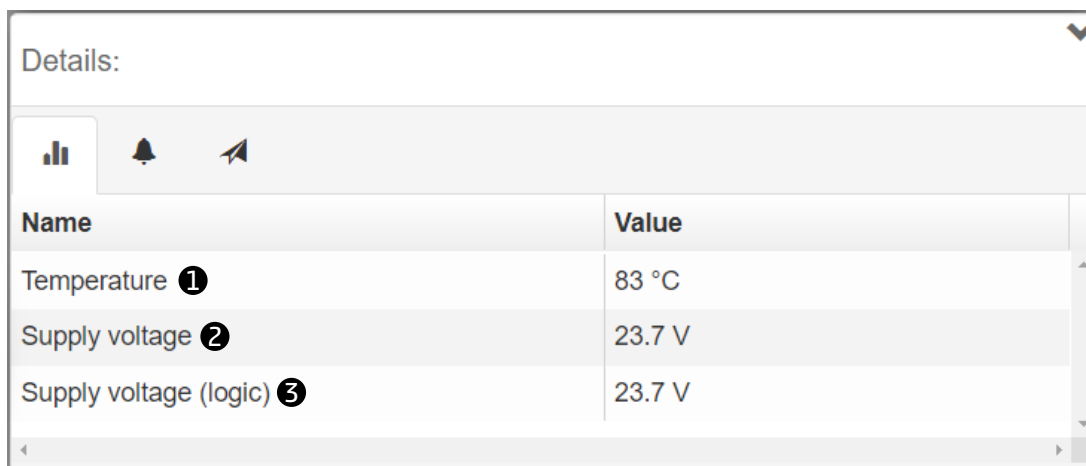

The screenshot shows a 'Details' window with a table of monitored variables. The table has two columns: 'Name' and 'Value'. The variables listed are Temperature (83 °C), Supply voltage (23.7 V), and Supply voltage (logic) (23.7 V). The variables are marked with circled numbers 1, 2, and 3 respectively.



Name	Value
Temperature ❶	83 °C
Supply voltage ❷	23.7 V
Supply voltage (logic) ❸	23.7 V

9.2.3 Alarms

The second tab on the details page displays possible CX4 module alarms.

- **4** No mapping: indicates that there are no accessory modules connected to the CX4 module.
- **5** Valve mapping error: this can occur if the positions of the subbases of the solenoid valves have been changed, moving them from their original position or adding new ones, or if a subbase fails to respond to the mapping request from the CX4 module.
- **6** CX4 module overheating.
- **7** Supply voltage of the CX4 module lower than the voltage given in the specifications.
- **8** Configuration error
- **9** No valve mapping: indicates that there are no solenoid valve subbases connected to the CX4 module.

Details: ▼





Event Name	Status ▼	Event Onset
Mapping absent 4	!	
Mapping valves error 5	!	
Overheating CX4 module 6	!	
Undervoltage CX4 module 7	!	
Mapping I/O modules error 8	!	
Fieldbus fatal error 9	!	
Configuration error 10	⚠	
Valves absent 11	!	
I/O modules absent 12	!	

9.2.4 Commands

The third tab of details on the CX4 module shows the commands that can be sent via UVIX to the device. The *Manual Mode* command ¹³ allows you to control the system manually from UVIX, sending configuration parameters to the CX4 module and to the individual connected accessory modules. In manual mode, you can command the solenoid valves ¹⁴ (par. 9.3.6). The history of the commands sent to the CX4 module from when communication with UVIX was started can be viewed under *Last Commands* ¹⁵.

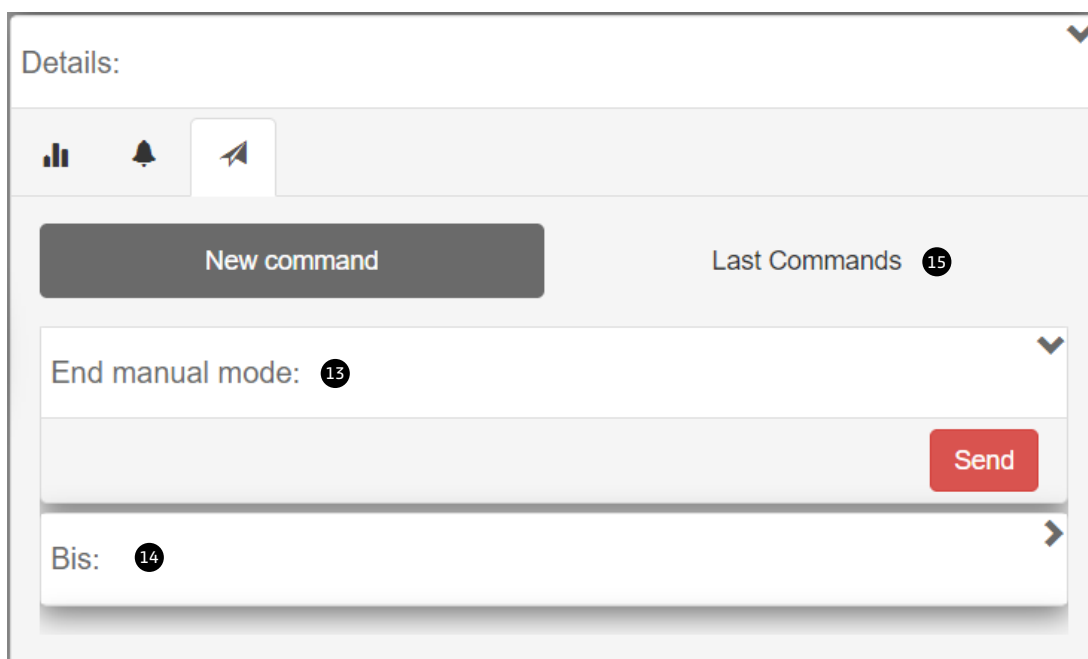
NOTE. If there are solenoid valve subbases connected to the CX4 module, the valve information can be reset at any time, without activating manual mode.



9.3 Series D coil valves and subbase

9.3.1 Status information

On the first page of UVIX, you can select one of the solenoid valves connected to the CX4 module in the configuration of a Series D valve island to view the general information of the individual subbase.

- ❶ Identification images of the coil valve mounted on the subbase.
- ❷ Position of the subbase in the assigned valve island after mapping.
- ❸ Name of the accessory module family: *Valve*.
- ❹ Solenoid valve family sub-type: 10 mm, 16 mm, 25 mm.
- ❺ Firmware version.
- ❻ Date and time of the last transmission of the variables between the subbase and UVIX.
- ❼ General status of the solenoid valve: ● *Not available*, ● *Ok*, ● *Alarm*.
- ❽ Operating status of the subbase:
 - *Init* → initialization (mapping and configuration of parameters).
 - *Work* → normal operation.
 - *Error* → subbase error.

Status information: ▼

	<p>❷ Position: 1</p> <p>❸ Family name: Valve</p> <p>❹ Subtype: 10 mm</p> <p>❺ Firmware: 2.11</p>	<p>❻ Last data transmission: 2022-09-21 09:45:04</p> <p>❼ Status: ●</p> <p>❽ Operational status: Work</p>
<p>❾ Configuration</p>		

9.3.2 Configuration

From the status information page, you can configure certain operating-related parameters of the solenoid valves 9.

- 10 Enable/disable the alarms that the valve can generate (default: all alarms enabled).
- 11 Enable/disable the Failsafe for each individual pilot: *Yes* enabled, *No* disabled (default).
- 12 Set the Failsafe status for each pilot for which the Failsafe has been enabled: *On* pilot activated, *Off* pilot deactivated (default).
- 13 Set the behaviour of the valve failure error (Coil Fault): *Latched*, *Not Latched* (default).
- 14 The buttons in the bottom bar of the tab allow you to send the configuration parameters to the module, save them on the PC, save them on the device or reset them to default values.

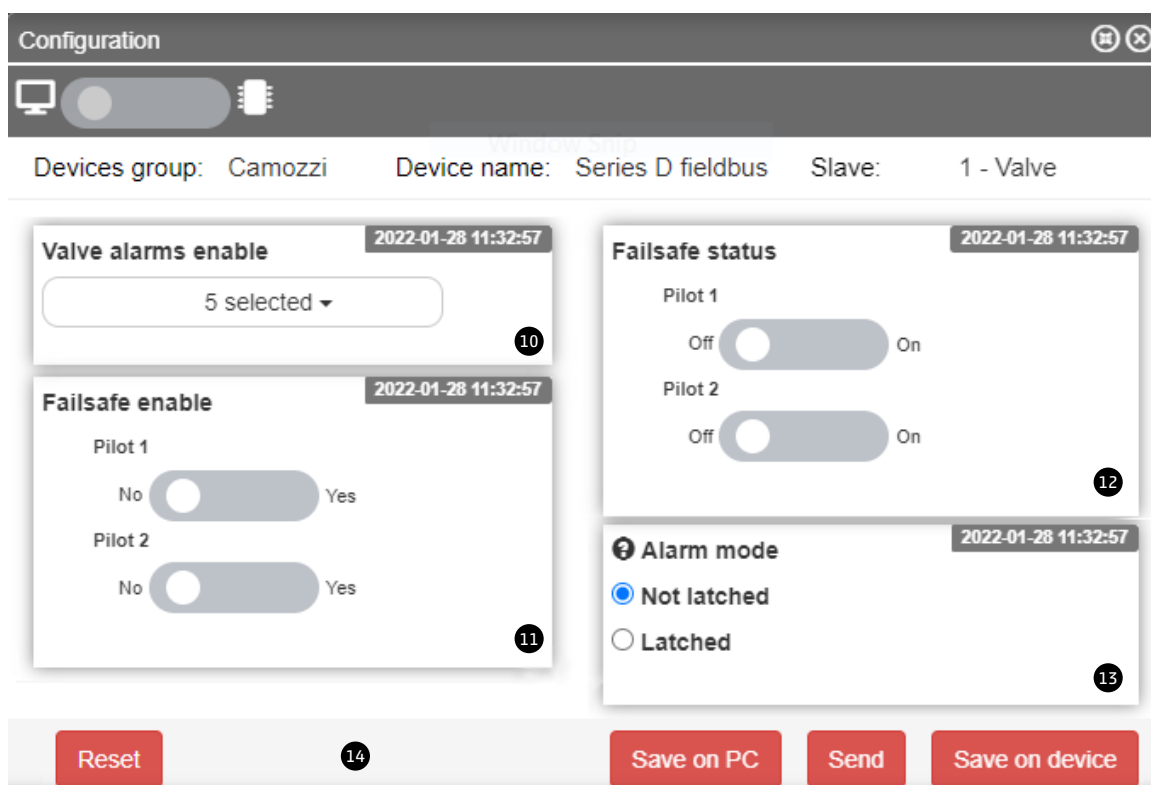

9.3.3 Details

9.3.4 Variables

The first tab on the details page shows the variables that are monitored by the subbase of an individual solenoid valve. These variables can be reset using the commands by selecting the CX4 module to which the subbases are connected (par. 9.3.6).

- ❶ subbase temperature.
- ❷ Cycles performed by the pilots in position 14 and position 12.
- ❸ Percentage health status of the pilots in position 14 and position 12.
- ❹ Status of the pilots in position 14 and position 12 (*On/Off*).
- ❺ Temperature of the pilots in position 14 and position 12.
- ❻ Errors of the pilots in position 14 and position 12.
- ❼ Communication errors between the CX4 module and the selected subbase.
- ❽ Gauge indicators that show graphically the percentage health status of the two pilots.

Details: ▼

📊 Variables
🔔 Alarms

Name	Value
Temperature subbase ❶	31 °C
Cycles coil 14 ❷	3799203
Cycles coil 12	3798813
Health status coil 14 ❸	100 %
Health status coil 12	100 %
Status coil 14 ❹	Off
Status coil 12	Off
Temperature coil 14 ❺	33 °C
Temperature coil 12	37 °C
Errors coil 14 ❻	0
Errors coil 12	0
Communication retries ❼	228

Health status coil 14 [%]

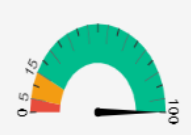

Health status coil 12 [%]

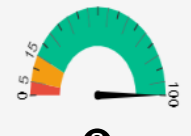

❽

9.3.5 Alarms

The second details tab displays the alarms of the subbase of the selected valve.

- ⑧ Communication alarm due to communication failure between CX4 module and subbase.
- ⑨ subbase overheating.
- ⑩ Overheating of the pilots in position 14 and position 12.
- ⑪ Overcurrent of the pilots in position 14 and position 12.
- ⑫ Alarm - solenoid valves closed in position 14 and position 12.
- ⑬ Energization malfunction of the solenoid pilots in position 14 and position 12.
- ⑭ Alarm - configuration of subbase parameters.
- ⑮ Replace valve warning.

Details: ▼

 Variables

 Alarms

Event Name	Status ▼	Event Onset
Communication alarm ⑧	!	
Overheating subbase ⑨	!	
Overheating coil 14	!	
Overheating coil 12 ⑩	!	
Overcurrent coil 14	!	
Overcurrent coil 12 ⑪	!	
Interrupted coil 14	!	
Interrupted coil 12 ⑫	!	
Fault coil 14	!	
Fault coil 12 ⑬	!	
Configuration alarm ⑭	⚠	
Valve substitution ⑮	⚠	

9.3.6 Commands

On the main page of the CX4 module (par. 9.2.4), there is a tab showing the commands for the solenoid valves. In particular, you can reset the valve information ¹⁶ (cycles, errors, health status). This operation needs to be performed when the valve connected to the subbase is replaced and can also be performed in normal working mode.

You can also control the individual pilots (position 12 and 14) of the solenoid valves ¹⁷. For this operation, the island must be in manual mode.

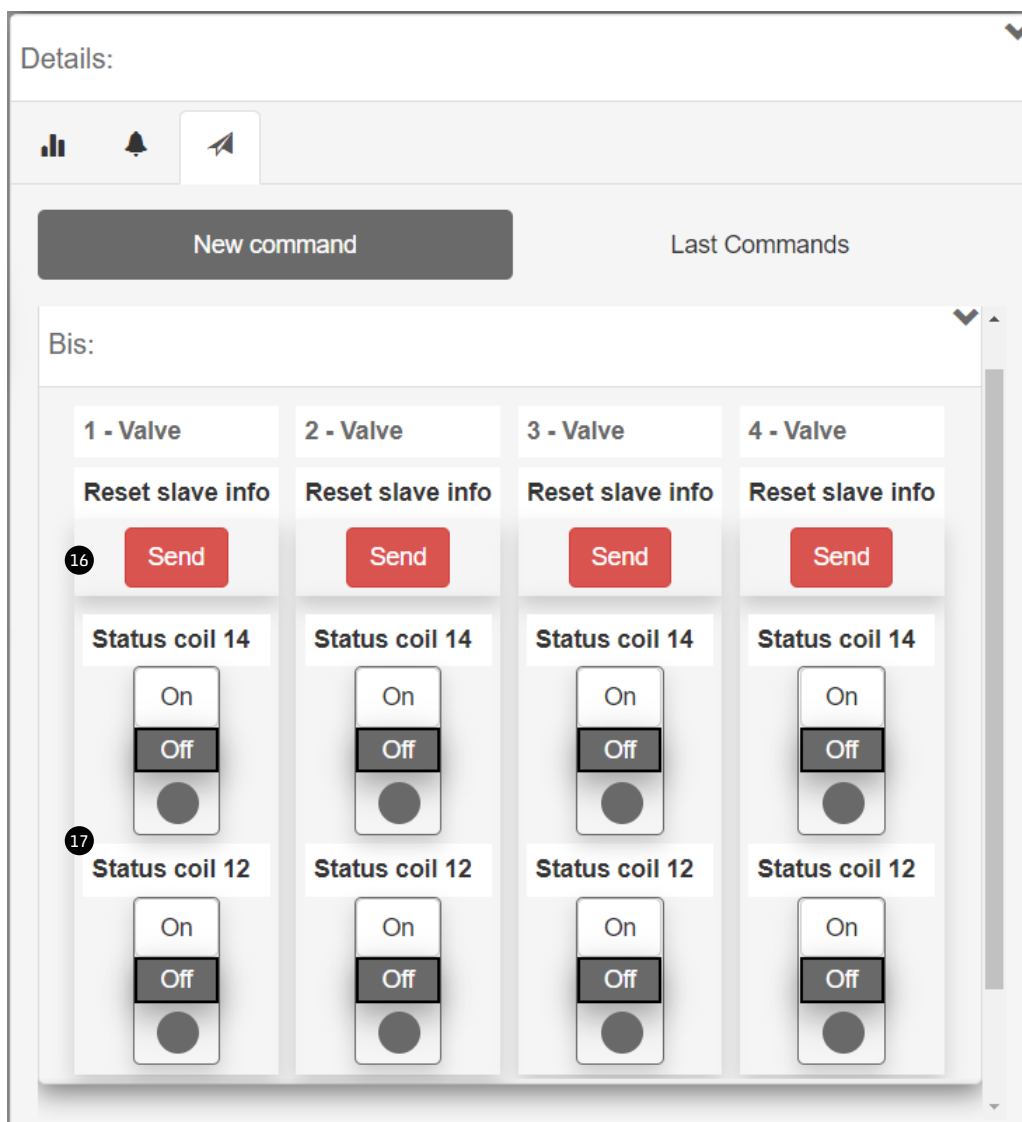

9.4 UVIX USB Gateway

The CX4 module can be connected to a PC via a USB cable. This connection - subject to prior installation of UVIX on the PC - allows you to communicate with the module through the Camozzi USB Gateway. For more information on using this tool, see the [UVIX Manual](#).

9.4.1 Main page

- ① Button to start up the USB Gateway and start communicating with the CX4 module.
- ② Button to stop communication with the CX4 module.
- ③ Button to access the UVIX Browser interface.
- ④ COM ports connecting the CX4 modules.
- ⑤ Virtual COM ports available and addresses of TCP connection for the connected COM ports.
- ⑥ Data received from the COM port.
- ⑦ Data received on the FEP of the UVIX system.

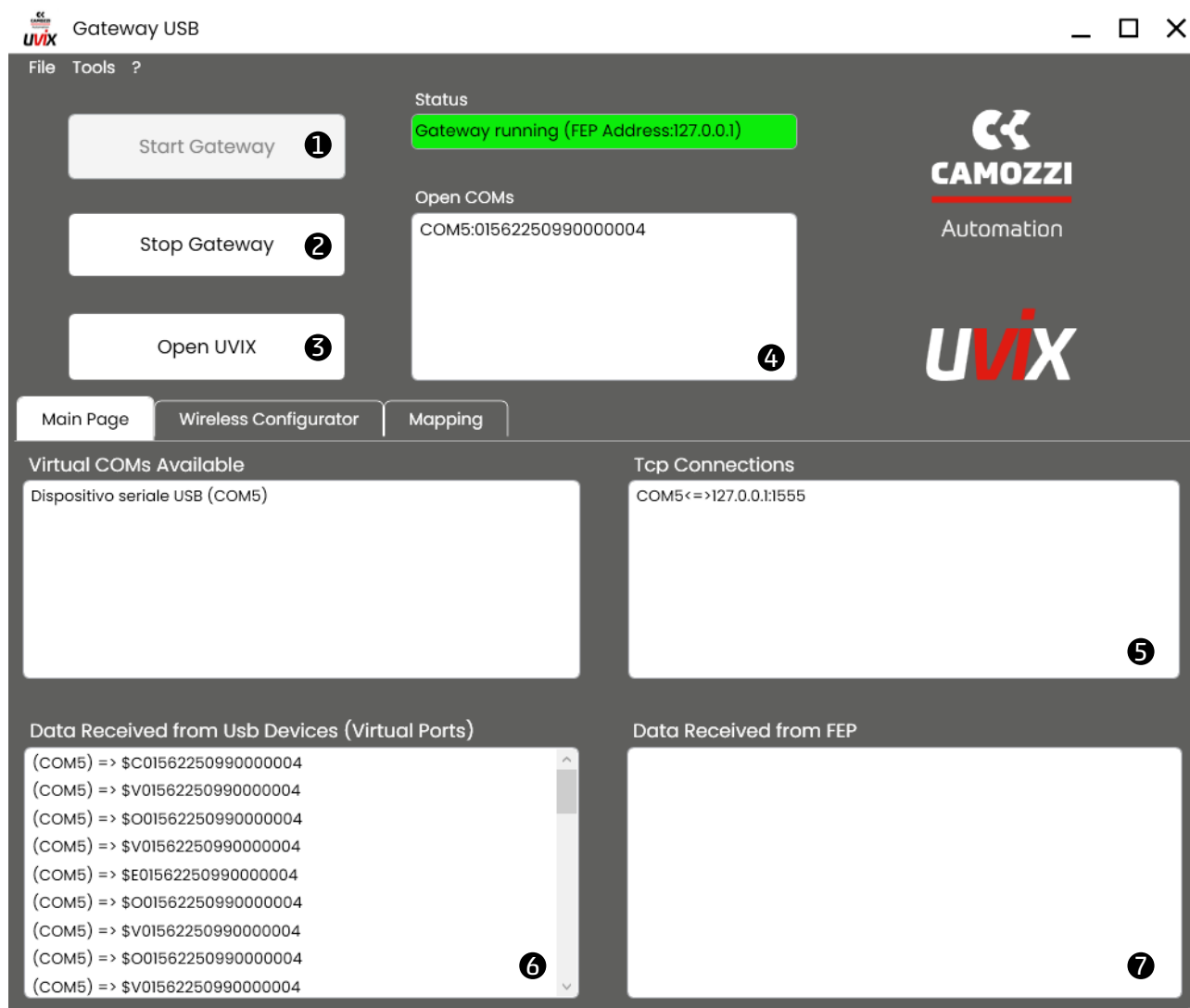

9.4.2 WiFi network configurator

In the tab for configuring the WiFi connection **8** (if available), you can read the parameters of the current connection and write any new ones for a new connection.

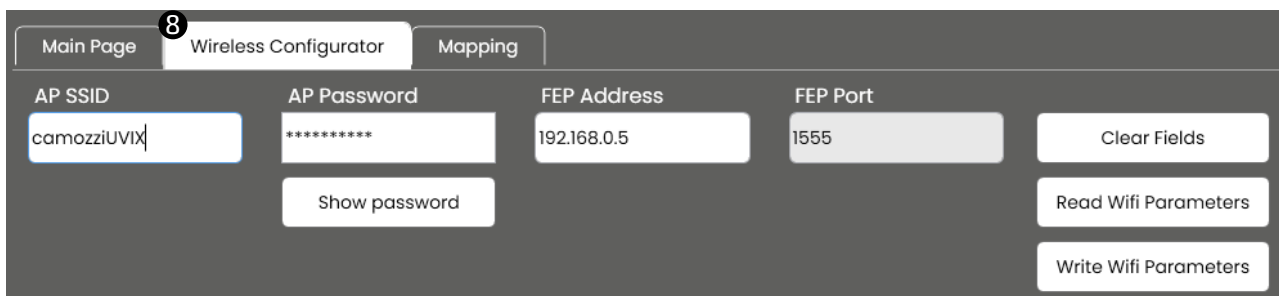

9.4.3 Mapping

In the last tab that can be consulted via the USB gateway, you can send a mapping request to the CX4 module. The *Require Mapping* button **9** remains pending until the next restart of the CX4 module.

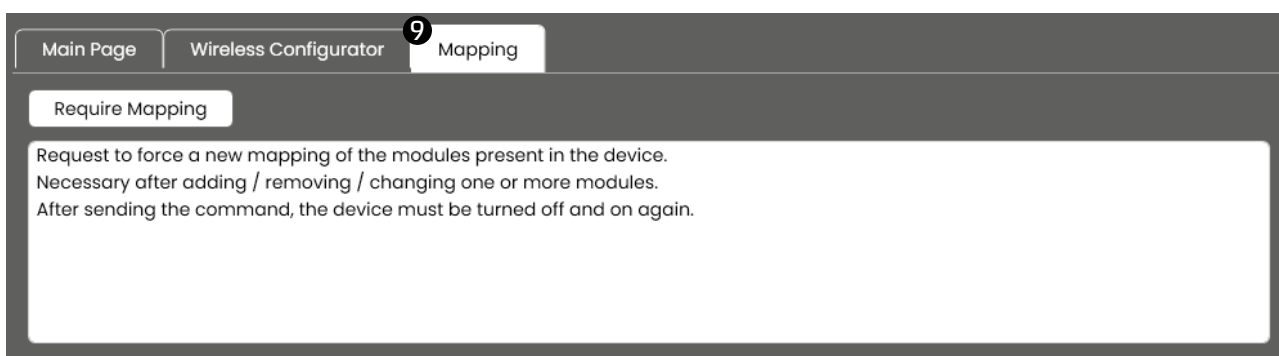

9.4.4 Firmware update

⚠ Before carrying out this operation, you must contact Camozzi support.

The USB Gateway allows you to update the firmware of the CX4 module through the window found under *Tools* → *Device Upgrade* **10**.

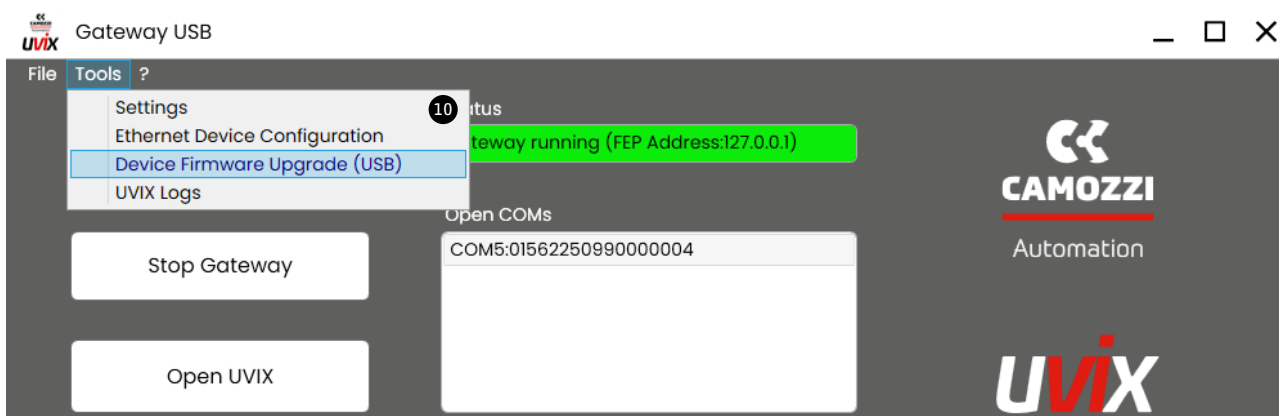

Chapter 9 Uvix

The firmware update window indicates the current version **11** and allows you to select the new executable to upload to the module **12**. The name of the firmware executable to be loaded must have the following nomenclature:

- *CX4M*: indicates that the device is the CX4 master of the valve island.
- *xx*: indicates the fieldbus type, so IO-Link → *LK*.
- *_0136_*: indicates the firmware version (in example the version is 01.36).
- *app.hex*: filename termination.

You must then put the device in *Boot mode* **13**.

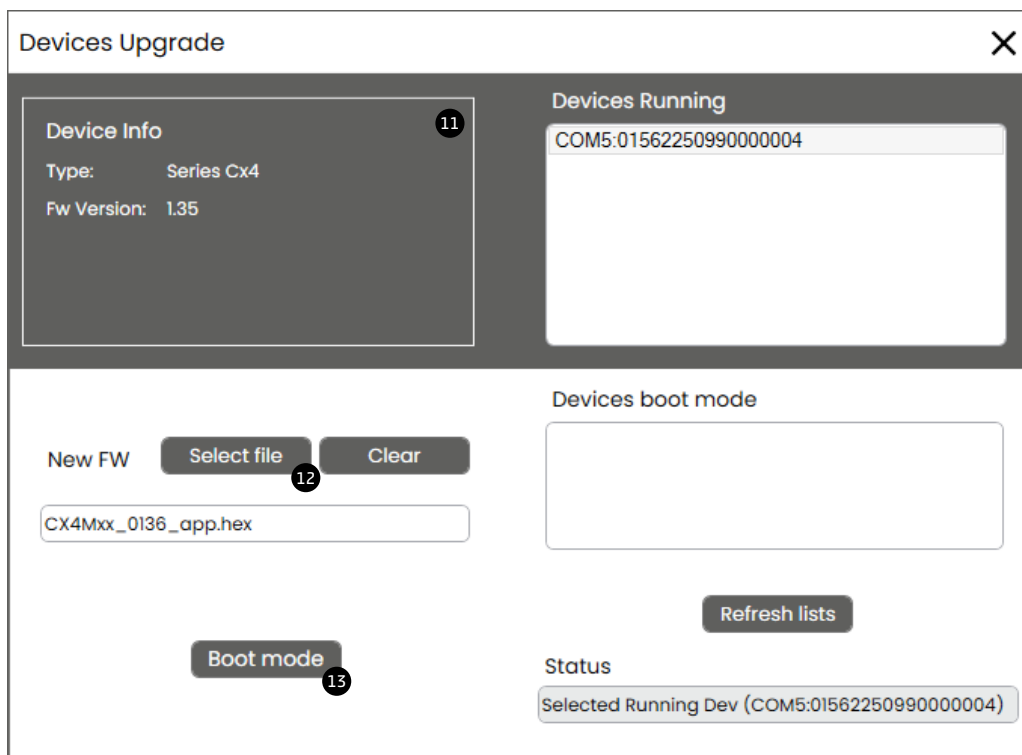

Once in Boot mode, the module is ready to load the new firmware into memory using the button **14**.

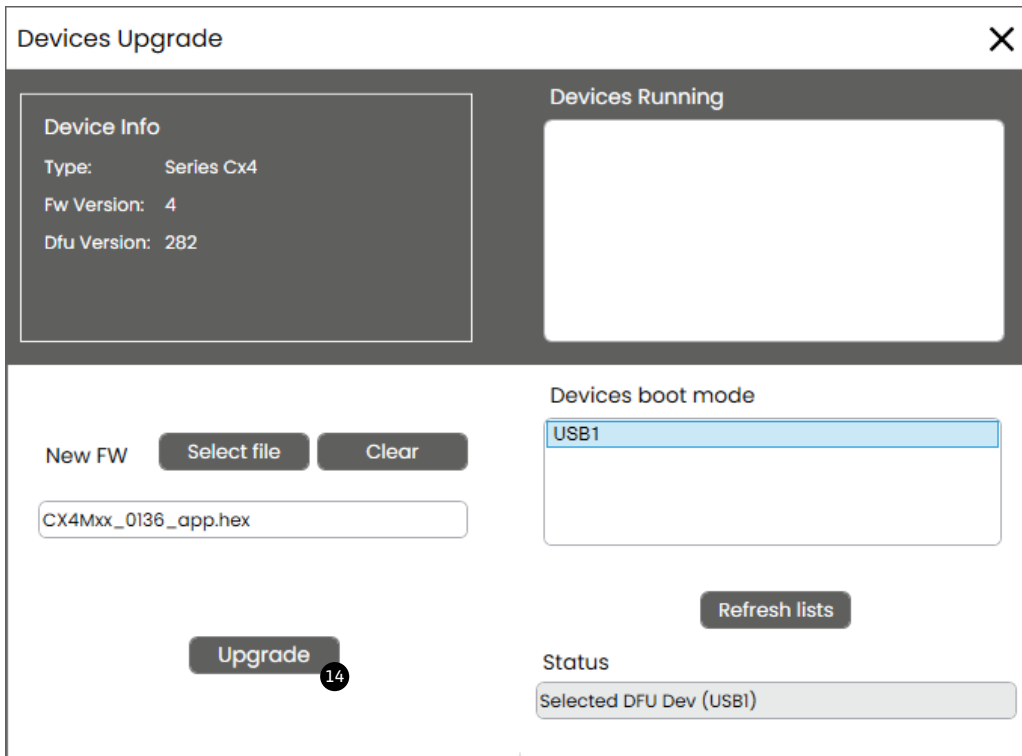

Wait for the new firmware to be loaded **15**.

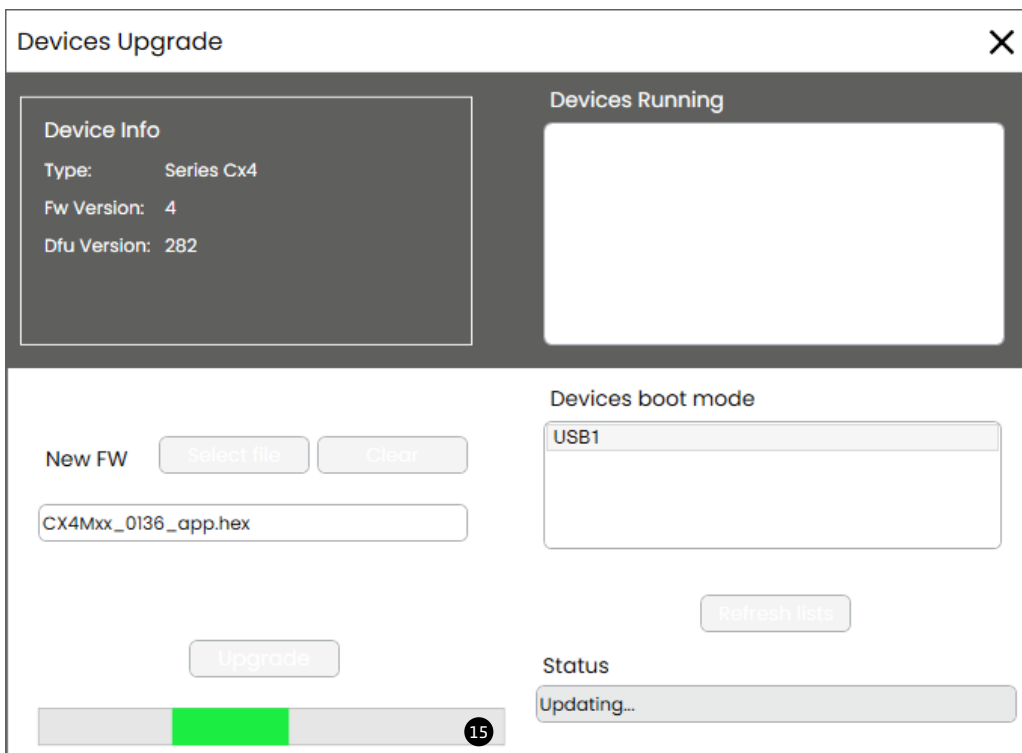

When the new firmware programming is completed, a confirmation window will be displayed ¹⁶.

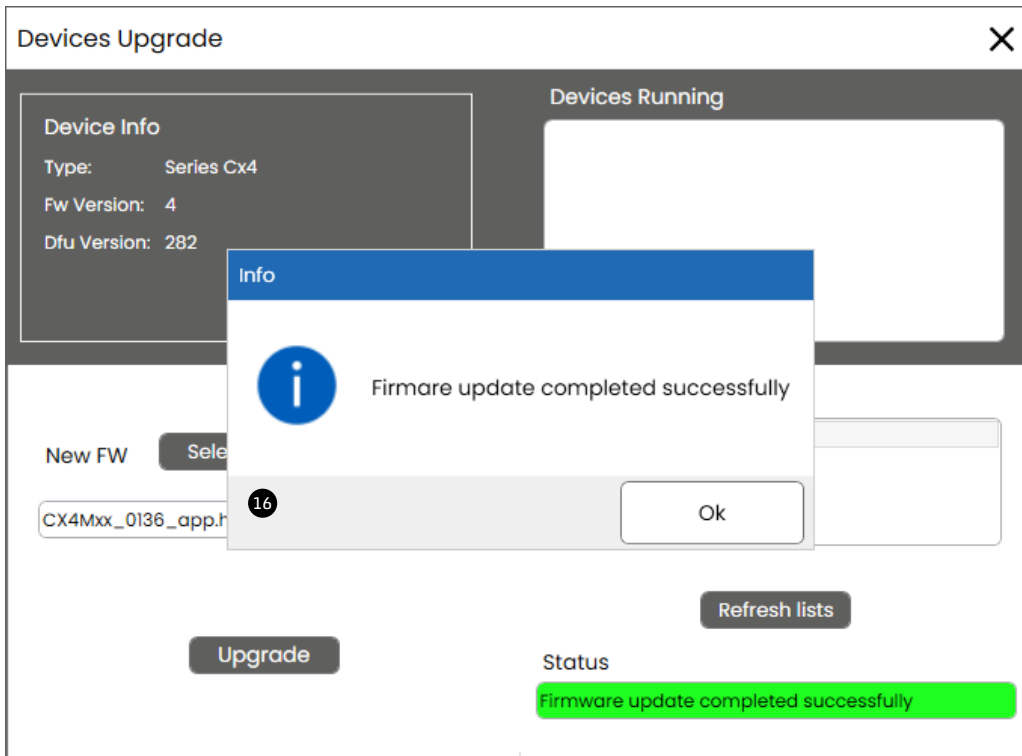

9.5 Communication with external applications

UVIX allows you to send managed variables to an external application that you create and customize to your needs. To configure this communication, refer to the [UVIX Manual](#).

If the communication is properly configured, the Web Service will publish a message every time it receives a variable from the valve island.

- **TS:** date and time of the sent message.
- **DevGr:** name of the device group to which the valve island belongs (e.g. *Packaging Machine*).
- **DevSerNum:** serial number of the device of 17 characters (es. 01302103990000035).
- **DevType:** device family. → Cx04.
- **DevName:** device name.
- **Slvld:** device ID.
 - 0 if is a variable of the CX4 master of the valve island.
 - >=1 if is a variable of the slave of the valve island.
- **SlvType:** slave family..

SlvType	Device
Cx04	Master of the valve island
Bis	Series D coil valves and subbase

- **SlvName:** slave name. If the variable is from the valve island master, the value will be Cx04.

- **VarId**: variable ID.

SlvType	VarId	Variables	Unit	Description
Cx04	1	Firmware version	xx.xx	CX4 master firmware version
	2	Temperature	°C	Internal temperature of the CX4 master
	3	Supply voltage	dV	Valve island power supply voltage
	4	Supply voltage (logic)	dV	Valve island logic supply voltage
Bis	1	Firmware version	xx.xx	Subbase firmware version
	2	Temperature subbase	°C	Internal temperature of the subbase
	3	Cycles coil 14	nr	Pilot activation cycles (14/12)
	4	Cycles coil 12		
	5	Health status coil 14	%	Pilot health status (14/12)
	6	Health status coil 12		
	7	Status coil 14	0 (OFF) 1 (ON)	Pilot activation status (14/12)
	8	Status coil 12		
	13	Temperature coil 14	°C	Pilot temperature (14/12)
	14	Temperature coil 12		
	15	Errors coil 14	nr	Pilot activation errors (14/12)
	16	Errors coil 12		
	17	Communication retries	nr	Failure to respond in communication on 485 protocol

- **VarVal**: Value of the variable represented with the format or units seen in the previous table.

Esempi

Following are some examples of messages sent to external applications from a Series D valve island:

- Sending the logic supply voltage, which is 23.9 volts, of a Series D island called *Packaging Machine 1*.

```
"TS":"2020-04-07T09:10:25", "DevGr":"default group", "DevSerNum":"01302103990000035", "DevType":"Cx04", "DevName":"Packaging Machine 1", "SlvId":0, "SlvType":"Cx04", "SlvName":"Packaging Machine 1", "VarId":4, "VarVal":"239"
```

- Sending the number of activation cycles performed by the pilot in position 14 (equal to 1838 cycles) of a Series D solenoid valve (with no associated name) in position 3 in a Series D valve island named *Assembly Machine*.

```
"TS":"2022-01-28T15:21:05", "DevGr":"default group", "DevSerNum":"01302103990000121", "DevType":"Cx04", "DevName":"Assembly Machine", "SlvId":3, "SlvType":"Cx04", "SlvName":"Bis", "VarId":3, "VarVal":"1838"
```

NFCamApp

10.1 Main overview

NFCamApp is an app for smartphones (Android and iOS) which allows you to communicate - via NFC technology - with the CX4 module to obtain general information on the module and on the valve island (if configured as such). You can also use the app for module configuration.

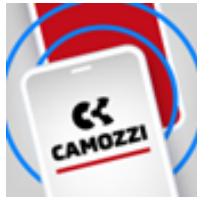

10.2 Main page

Once the CX4 module has been scanned, on the homepage, alongside the antenna positioned under the symbol , you can view the Camozzi series of the device **1** (Series CX4), assign a name to the device **2** and clone **3** the entire configuration (parameters of the CX4, the IO modules and the solenoid valve subbases) of the system, both in Stand Alone mode and as a Valve Island, to another system with a CX4 module compatible with the same fieldbus.

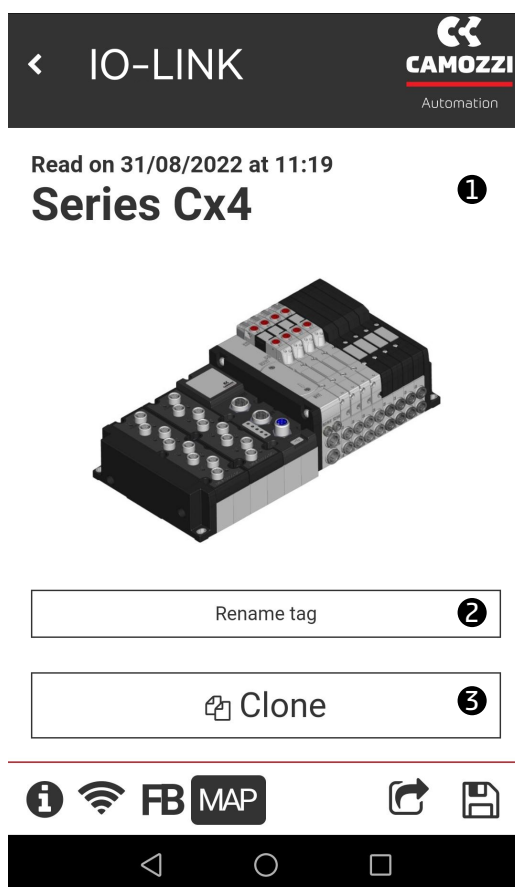

You can also access other pages of the app via the icons at the bottom of the homepage.



- **4** General module information page.
- **5** WiFi network information page (if available).
- **6** Bus information page.
- **7** Page to request new mapping.
- **8** Share module and/or island configuration.
- **9** Save the configuration of the scanned module or island.

10.3 General information

The first selectable page  displays general information about the scanned CX4 module.

- ① Device family: *Series CX4*.
- ② Subtype of the CX4 module family: *Stand-alone, D1, D2, D4 e D5*.
- ③ Firmware version.
- ④ Status of the WiFi connection: *Yes - WiFi module present, No - no WiFi module*.
- ⑤ Type of fieldbus: *IO-Link*.
- ⑥ The serial number consists of 17 characters.
- ⑦ Version of the app.

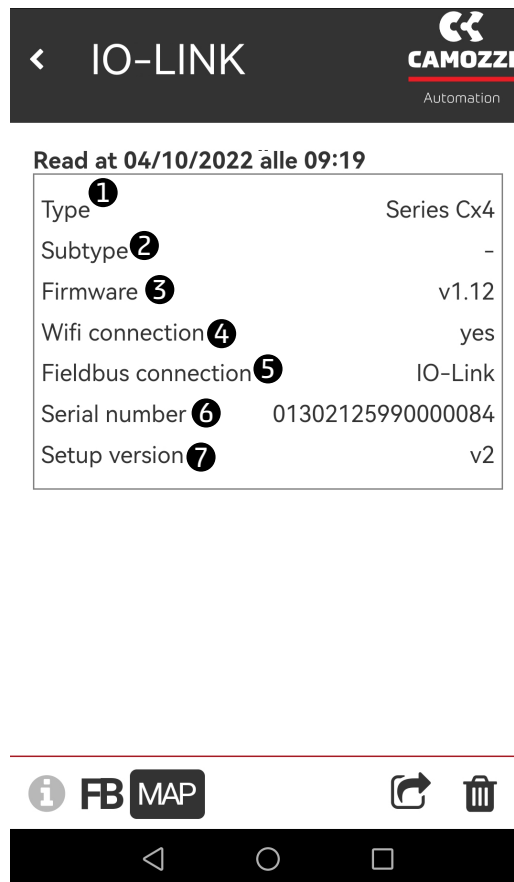

10.4 WiFi information

The WiFi connection information page  is found only if there is a WiFi module connected inside the CX4 module, otherwise it is not displayed.

- ❶ MAC address of the WiFi module.
- ❷ IP version of the WiFi connection.
- ❸ Name of the WiFi network to which the device is connected.
- ❹ WiFi network password.
- ❺ FEP address to which the devices are connected.
- ❻ FEP port to which the device is connected.
- ❼ Button for changing the data of the WiFi network to which you want to connect the module.

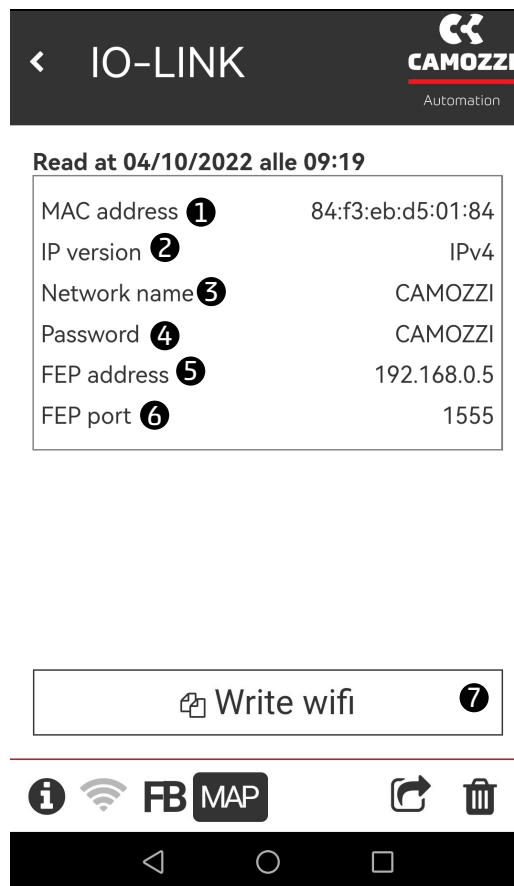

10.5 Mapping request

The last available page  in the app, you can request a new system mapping using the button *Require* **1**. Once the request has been made, it remains pending (the button will change to *Pending* **2**) until the next restart of the CX4 module.

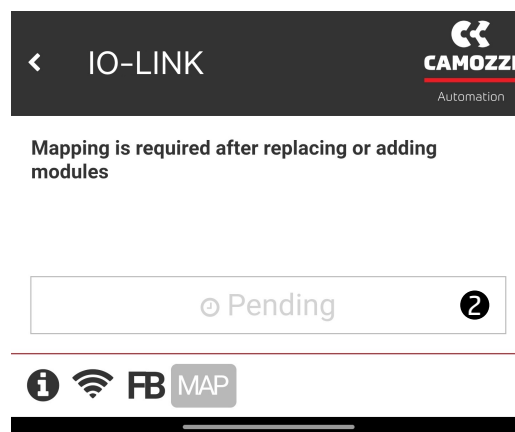
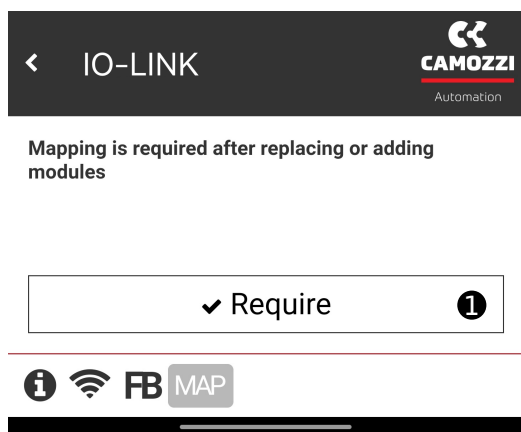

Contacts

Camozzi Automation SpA

Single-member company

Via Eritrea, 20/I

25126 Brescia - Italy

Tel. +39 030 37921

Fax +39 030 2400464

info@camozzi.com

www.camozzi.com

Product Certification

National and International Directives, Regulations and Standards

productcertification@camozzi.com

Technical assistance

Technical information

Product information

Special products

Tel.+39 030 3792390

service@camozzi.com



Automation

A Camozzi Group Company

camozzi.com

Contacts

Camozzi Automation S.p.A.

Società Unipersonale

REGISTERED OFFICE

Via R. Rubattino, 81

20134 Milano

Italy

OPERATIONAL HEADQUARTERS

Via Eritrea, 20/1

25126 Brescia

Italy

Tel. +39 030 37921

marketing@camozzi.com

Customer Service

Tel. +39 030 3792790

service@camozzi.com

Export Department

Tel. +39 030 3792253

sales@camozzi.com