

# S26 remote and direct mount diaphragm seals

## Diaphragm seals for ABB pressure transmitters



Engineered solutions for all applications

**Measurement made easy**

—  
PGD100 with remote  
S26RA diaphragm seal

PDD300 with direct  
mount and remote  
S26RA diaphragm seals

### Introduction

The 2600T and P-Series pressure transmitters provide comprehensive range of top quality pressure measurement products, specifically designed to meet the widest range of applications ranging from arduous conditions in offshore oil and gas to the laboratory environment of the pharmaceutical industry.

### For more information

Further publications for 2600T and P-Series pressure transmitters are available for free download from:

[www.abb.com/pressure](http://www.abb.com/pressure)

or by scanning this code:



# Index

|          |  |          |
|----------|--|----------|
| <b>1</b> | <b>Introduction</b> .....                        | <b>3</b> |
|          | Data sheet and instruction manual structure..... | 3        |
|          | Models covered by this manual.....               | 3        |
|          | Product description .....                        | 3        |

## SECTION A - DATA SHEET

|          |   |    |
|----------|---|----|
| <b>2</b> | <b>Model S26 seals for remote and direct mount</b> . 4    |    |
|          | Remote Seals Overview.....                                | 4  |
|          | Seal system selection criteria .....                      | 4  |
|          | Ordering Information.....                                 | 5  |
|          | Capillary length table .....                              | 6  |
|          | Direct mount seals table .....                            | 9  |
|          | Specification – operative limits .....                    | 12 |
|          | Specification – performance .....                         | 15 |
|          | Model codes .....   | 18 |
|          | Wafer Remote Seal (S26WA and S26WE) .....                 | 19 |
|          | Rotating flange diaphragm seals (S26Rx).....              | 20 |
|          | Rotating flange diaphragm seal - Ring Joint (S26RR) ..... | 22 |
|          | Fixed flange diaphragm seals – (S26FA, S26FE) 23          |    |
|          | Off-line Threaded Connection Seal (S26TT)....             | 25 |
|          | Off-Line Flanged Connection Remote Seal (S26Mx) .....     | 26 |
|          | Remote Seal for Urea Service (S26PN).....                 | 27 |
|          | Button Type remote seal (S26BN) .....                     | 28 |
|          | Food and Sanitary seal (S26SS) .....                      | 30 |
|          | Pulp and Paper diaphragm seals (S26KN) .....              | 35 |
|          | Order information.....                                    | 38 |

## SECTION B - INSTRUCTION MANUAL

|          |  |           |
|----------|--|-----------|
| <b>3</b> | <b>Safety</b> .....  | <b>74</b> |
|          | General safety information.....  | 74        |
|          | Improper use.....  | 75        |
|          | Technical limit values .....   | 75        |
|          | Warranty provision .....   | 75        |
|          | Use of instruction .....   | 75        |
|          | Operator liability .....   | 76        |
|          | Qualified personnel .....  | 76        |
|          | Returning devices .....  | 76        |
|          | Disposal .....   | 76        |
|          | Information on WEEE Directive 2012/19/EU (Waste Electrical and Electronic Equipment) ..... | 76        |
|          | Transport and storage.....   | 76        |
|          | Safety information for electrical installation .....                                       | 76        |
|          | Safety information for inspection and maintenance 76                                       |           |
| <b>4</b> | <b>Overview</b> .....  | <b>77</b> |
|          | Seal system .....  | 77        |
| <b>5</b> | <b>Opening the box</b> .....   | <b>77</b> |
|          | Identification .....   | 77        |
|          | Handling.....  | 77        |
| <b>6</b> | <b>Mounting</b> .....  | <b>78</b> |
|          | General .....  | 78        |
|          | Flow measurement .....   | 78        |
|          | Liquid level measurement.....  | 79        |
|          | Interface level measurement .....  | 81        |
|          | Density measurement .....  | 81        |
|          | Gauge pressure measurement .....   | 82        |
|          | Absolute pressure measurement .....  | 82        |
|          | Mounting a diaphragm-seal(s)-equipped transmitter82  |           |
| <b>7</b> | <b>Connecting low side compensation leg</b> .....  | <b>83</b> |
|          | Open Tank Installation.....  | 83        |
|          | Closed Tank Installation .....   | 83        |

# 1 Introduction

## Data sheet and instruction manual structure

The present data sheet and instruction manual is composed of 2 sections:

- section A - DATA SHEET, which includes chapter 2, provides indications for seal system selection, Functional Specifications and ordering code configuration;
- section B - INSTRUCTION MANUAL , which includes chapters from 3 to end provides information for installing the S26 diaphragm-seal-equipped pressure transmitters. Instructions covering all aspects of the transmitters, which are not related to installation of the remote seals, are included in the relevant operating instruction.

Please read this manual before working with the product.

In case of additional information needs please contact ABB at the links you find at last page of this manual or at the web site:

<http://www.abb.com/pressure>.

The products described in the present manual are not intended for use in NUCLEAR-QUALIFIED environments/applications.

## Models covered by this manual

The present manual can be used for all the diaphragm-seal-equipped pressure transmitters.

## Product description

The S26 Series Seal System is a protective device used to isolate 2600T and P-Series transmitters from the process fluid, while faithfully conveying pressure signals. They enable the measurement of not only pressure and vacuum, but also of derived variables, including flowrate, level and density. At extreme high or low temperatures and with challenging process media, these may cause damage to the sensitive electronics at the transmitter sensor if they are in direct contact with the diaphragm. Remote seals mitigate these extreme temperatures by using a small cross-sectional area coupling and fill fluids with low thermal conductivity.

## SECTION A - DATA SHEET

### 2 Model S26 seals for remote and direct mount

#### Remote Seals Overview

The S26 seals are used in combination with 2600T and P-Series pressure transmitters, allowing differential, gauge or absolute pressure measurement.

Connection of the seal(s) to the relevant transmitter can be achieved as follows :

- directly mounted with a short capillary connecting the “integral” seal to the transmitter sensor;
- through a capillary system which link the transmitter sensor to a „remote” seal of any version.

Using remote seal the transmitter can be selected with:

- two seals using same fill fluid, capillary and diaphragm size
- one seal having the other side configured with a process flange for wet/dry leg connection or a blind flange providing vacuum or atmospheric reference.

Model 266HR/NR transmitters have always one remote seal only, with a selectable reference to atmosphere or vacuum respectively for gauge or absolute pressure measurements.

The S26 Series Seal System is a protective device used to isolate 2600T and P-Series transmitters from the process fluid. The seal system provides a flexible diaphragm seal between the process fluid and a liquid filled capillary tube connected to the body of the transmitter. The diaphragm isolates the process fluid while the filled capillary tube hydraulically transmits the process pressure to the transmitter sensor. The capillary of remote seal is corrosion-resistant with robust construction in stainless steel with spiral armour protection, also PVC jacket; PVC protection is always recommended except for high temperature application, where stainless steel armour is suggested. The all welded construction assures reliable operation over the widest range of operating temperature and under vacuum conditions.

For certain applications, use of seal is necessary to prevent the process fluid from leaving its enclosure, due to reasons such as:

- the process fluid has solids in suspension or is highly viscous and can foul impulse lines.
- the process fluid can solidify in impulse lines or the transmitter.
- the process fluid is too hazardous to enter the control area where the transmitter is located.
- the process temperature exceeds the recommended limits for the transmitter.
- the application is interface level or density measurement.

Remote seals offer the required constant and equal specific gravity of the pressure transfer fluid on the high and low sides of the transmitter.

- the transmitter must be located away from the process for easier maintenance.

The S26 series is available with process connections for ASME, EN or JIS pipe flanges, wedge flow elements, chemical tees, and threaded pipe fittings. Extended diaphragm remote seals, suitable for connection to 2 in - 3 in or 4 in flanged tank nozzles or flanged tees, permit the seal diaphragm to be located flush with the inside of a tank or pipe. Sanitary type seals meet the stringent requirements of sanitary food, dairy, pharmaceutical and BioTech applications, offering FDA approved fillings and compliance with 3-A Sanitary Standards. Fill fluids with FDA are defined as food fills and are Generally Recognized As Safe (GRAS) by the US Food and Drug Administration (FDA).

#### Seal system selection criteria

Application of an S26 system in direct mount or remote seal configuration to 2600T and P-Series pressure transmitters affects performances of original devices. Effects are evident in:

- Accuracy
- Temperature effects
- Dynamic response

Accuracy is only marginally affected when seal diaphragm stiffness is relevant compared with sensor stiffness.

This is the only characteristic of the S26 system which has role on accuracy performance. High stiffness of diaphragm associated with low URL might produce increased errors of linearity, hysteresis, and long term stability; when diaphragm stiffness is accuracy related also temperature effects are significantly affected.

Some basic considerations on diaphragm stiffness help understanding effects introduced by S26 system associated with transmitters. This is physically defined by the ratio between the pressure variation applied to the diaphragm and the corresponding volume variation. The stiffness is not linear along the whole diaphragm volumetric displacement, but the S26 design is such to maintain the system linear within the service conditions of the transmitter such as:

- Operating pressure range
- Operating static pressure (for differential transmitters)
- Ambient and process temperature limits

Diaphragm stiffness is a function of material and thickness (elastic coefficient), diameter (type), convolution shape and geometry (design defined).



S26 system has effect on temperature performance of the complete transmitter. This effect is mostly on zero of the instrument and is produced by the expansion of the fill fluid into the closed volume formed by the transmitter flange cavity the capillary volume and the remote seal volume. This volume filled with a fluid with specific expansion coefficient; change in temperature of the measuring device produce a volume variation which is absorbed by the remote diaphragm, whose stiffness produces a change in the fluid pressure: this is the zero error. In real application the transmitter/seal system is not the same and stable temperature.

Therefore the errors referred in this document for each type of diaphragm and different fluids should be taken as a reference for qualitative evaluation and not a true behaviour in normal application conditions. Should again be recognized that the stiffness of diaphragm and in this case, the thermal coefficient of fluid are the parameter to take into account.

Application of S26 seal to transmitters increases the original time response. The amount of the increase depends from the number of elements and condition of the instrument as follow:

- transmitter sensor range
- physical configuration (i.e. a remote seal on other side)
- type of measure/number of seal (one or two)
- fill fluid viscosity of the S26 system applied
- ambient temperature (affects the transmitter and the capillary) and process temperature on the seal diaphragm
- capillary length

The delay introduced by the seal may be considered as an added constant time to the one of the associated transmitter.

For obtaining the best application solution:

- choose sensor code with URL closest to application SPAN
- select largest diameter diaphragm seal related to URL.
- keep the capillary length as short as possible
- select the fill fluid that suits the most extreme process conditions expected (highest temperature and lowest pressure) and it is compatible with the process fluid.
- In vacuum application, choose always the all welded version and mount the transmitter primary 30 cm/12 inches or more below the bottom seal connection.
- In a two-seal system use the same diaphragm size, capillary length and fill fluid on each side of the transmitter

## Ordering Information

The transmitter and each seal system are each identified by a product code number. These code numbers are stamped on the transmitter nameplate and each character identifies specific product features. Refer to ordering information for a detailed explanation of the product code numbers.

Industrial application in chemical, sanitary, food and any other process industries may require seal configurations and/or process connection different from those reported in this document. Each “special” should be evaluated by ABB to check the correctness and its level of functionality. Ask for the “S26 series seal form” to define precisely the measuring problem and application requirements.

ABB can also cooperate with you by developing a special remote seal for problems requiring individual solutions.

### **IMPORTANT**

PLEASE CONTACT YOUR LOCAL ABB OFFICE OR REPRESENTATIVE FOR ADDITIONAL INFORMATION, SPECIFIC SEAL DATA AND APPLICABILITY.





## ...Capillary length table

### PXD100 models

| Seal model                       | Seal type                                       | Seal diaphragm size (thickness) [flange type]      | One seal construction |    |    |    |    |      | Mnemonic |    |
|----------------------------------|---|--|-----------------------|----|----|----|----|------|----------|----|
|                                  |   |  | SENSOR                |    |    |    |    |      |          |    |
|                                  |   |  | C                     | F  | L  | D  | K  | R    |          |    |
| S26WA<br>S26WE                   | Wafer (ASME and EN standards)                   | 1.5 in / DN 40                                     | -                     | -  | 3  | 5  | 5  | 5    | P1.5     |    |
|                                  |   | 2 in / DN 50                                       | -                     | 2  | 6  | 8  | 8  | 8    | P2       |    |
|                                  |   | 3 in / DN 80                                       | -                     | 4  | 10 | 10 | 10 | 12   | P3       |    |
|                                  |   | 1.5 in / DN 40 (low)                               | -                     | -  | 4  | 6  | 6  | 6    | F1.5     |    |
|                                  |   | 2 in / DN 50 (low)                                 | -                     | 3  | 8  | 12 | 16 | 16   | F2       |    |
|                                  |   | 3 in / DN 80 (low)                                 | -                     | 6  | 10 | 16 | 16 | 16   | F3       |    |
| S26FA<br>S26FE<br>S26RA<br>S26RE | Flanged flush diaphragm (ASME and EN standards) | 2 in / DN 50                                       | -                     | 2  | 6  | 8  | 8  | 8    | P2       |    |
|                                  |   | 3 in / DN 80                                       | -                     | 4  | 10 | 10 | 10 | 12   | P3       |    |
|                                  |   | 4 in / DN 100                                      | -                     | 4  | 10 | 10 | 10 | 12   | P3       |    |
|                                  |   | 1 in / DN 25 (low)                                 | -                     | -  | 3  | 3  | 3  | 3    | F1       |    |
|                                  |   | 1.5 in / DN 40 (low)                               | -                     | -  | 4  | 6  | 6  | 6    | F1.5     |    |
|                                  |   | 2 in / DN 50 (low)                                 | -                     | 3  | 8  | 12 | 16 | 16   | F2       |    |
|                                  |   | 3 in / DN 80 (low)                                 | -                     | 6  | 10 | 16 | 16 | 16   | F3       |    |
|                                  |   | 4 in / DN 100 (low)                                | -                     | 6  | 10 | 16 | 16 | 16   | F3       |    |
|                                  |   | Flanged extended diaphragm (ASME and EN standards) | 2 in / DN 50          | -  | -  | 4  | 6  | 6    | 6        | E2 |
|                                  |   |  | 3 in / DN 80          | -  | 3  | 8  | 10 | 10   | 10       | E3 |
| 4 in / DN 100                    | -   |  | 4                     | 10 | 10 | 10 | 12 | P3   |          |    |
| 2 in / DN 50 [fixed]             | -   |  | -                     | 4  | 6  | 6  | 6  | F1.5 |          |    |
| 3 in / DN 80 [fixed]             | -   |  | 6                     | 10 | 12 | 12 | 12 | F2.5 |          |    |
| 4 in / DN100 [fixed]             | -   |  | 6                     | 10 | 12 | 12 | 12 | F2.5 |          |    |

**PxD300 models**

| Seal model                       | Seal type  | Seal diaphragm size (thickness) [flange type] | Two seals construction |   |    |    |    |    | One seal construction |   |    |    |    |    |    |    |    |    |    |    |    | Mnemonic |    |    |      |      |    |
|----------------------------------|--|---|------------------------|---|----|----|----|----|-----------------------|---|----|----|----|----|----|----|----|----|----|----|----|----------|----|----|------|------|----|
|                                  |  |   | SENSOR                 |   |    |    |    |    | SENSOR                |   |    |    |    |    |    |    |    |    |    |    |    |          |    |    |      |      |    |
|                                  |  |   | C                      | F | H  | M  | N  | S  | C                     | F | H  | L  | D  | K  | M  | N  | R  | S  | T  | V  | Y  |          | W  |    |      |      |    |
| S26WA<br>S26WE                   | Wafer (ASME and EN standards)                      | 1.5 in / DN 40                                | —                      | 1 | 4  | 5  | 5  | 5  | —                     | — | 4  | 3  | 5  | 5  | 5  | 5  | 5  | 5  | 5  | 5  | 5  | 5        | —  | —  | P1.5 |      |    |
|                                  |  | 2 in / DN 50                                  | —                      | 3 | 8  | 8  | 10 | 10 | —                     | 2 | 8  | 6  | 8  | 8  | 8  | 8  | 8  | 8  | 8  | 8  | 8  | 8        | 8  | —  | —    | P2   |    |
|                                  |  | 3 in / DN 80                                  | 1.5                    | 6 | 8  | 16 | 16 | 16 | —                     | 4 | 8  | 10 | 10 | 10 | 10 | 10 | 10 | 10 | 10 | 10 | 10 | 10       | 10 | —  | —    | P3   |    |
|                                  |  | 1.5 in / DN 40 (low)                          | —                      | 3 | 6  | 6  | 8  | 8  | —                     | — | 6  | 3  | 6  | 6  | 6  | 6  | 6  | 6  | 6  | 6  | 6  | 6        | 6  | —  | —    | F1.5 |    |
|                                  |  | 2 in / DN 50 (low)                            | 1                      | 4 | 8  | 12 | 16 | 16 | —                     | 3 | 8  | 8  | 12 | 12 | 12 | 16 | 16 | 16 | 16 | 16 | 16 | 16       | 16 | 16 | —    | —    | F2 |
|                                  |  | 3 in / DN 80 (low)                            | 2                      | 8 | 10 | 16 | 16 | 16 | —                     | 6 | 10 | 10 | 16 | 16 | 16 | 16 | 16 | 16 | 16 | 16 | 16 | 16       | 16 | 16 | —    | —    | F3 |
| S26FA<br>S26FE<br>S26RA<br>S26RE | Flanged flush diaphragm (ASME and EN standards)    | 2 in / DN 50                                  | —                      | 3 | 8  | 8  | 8  | 8  | —                     | 2 | 8  | 6  | 8  | 8  | 8  | 8  | 8  | 8  | 8  | 8  | 8  | 8        | 8  | —  | —    | P2   |    |
|                                  |  | 3 in / DN 80                                  | 1.5                    | 6 | 10 | 16 | 16 | 16 | —                     | 4 | 10 | 10 | 10 | 10 | 10 | 10 | 10 | 10 | 10 | 10 | 10 | 10       | 10 | —  | —    | P3   |    |
|                                  |  | 4 in / DN 100                                 | 1.5                    | 6 | 10 | 16 | 16 | 16 | —                     | 4 | 10 | 10 | 10 | 10 | 10 | 10 | 10 | 10 | 10 | 10 | 10 | 10       | 10 | —  | —    | P3   |    |
|                                  |  | 1 in / DN 25 (low)                            | —                      | — | 3  | 3  | 3  | 3  | —                     | — | 3  | 3  | 3  | 3  | 3  | 3  | 3  | 3  | 3  | 3  | 3  | 3        | 3  | —  | —    | F1   |    |
|                                  | Flanged extended diaphragm (ASME and EN standards) | 1.5 in / DN 25 (low)                          | —                      | 3 | 6  | 6  | 8  | 8  | —                     | — | 6  | 4  | 6  | 6  | 6  | 6  | 6  | 6  | 6  | 6  | 6  | 6        | 6  | —  | —    | F1.5 |    |
|                                  |  | 2 in / DN 50 (low)                            | 1                      | 4 | 8  | 12 | 16 | 16 | —                     | 3 | 8  | 8  | 12 | 12 | 12 | 16 | 16 | 16 | 16 | 16 | 16 | 16       | 16 | —  | —    | F2   |    |
|                                  |  | 3 in / DN 80 (low)                            | 2                      | 8 | 10 | 16 | 16 | 16 | —                     | 6 | 10 | 10 | 16 | 16 | 16 | 16 | 16 | 16 | 16 | 16 | 16 | 16       | 16 | —  | —    | F3   |    |
|                                  |  | 4 in / DN 100 (low)                           | 2                      | 8 | 10 | 16 | 16 | 16 | —                     | 6 | 10 | 10 | 16 | 16 | 16 | 16 | 16 | 16 | 16 | 16 | 16 | 16       | 16 | —  | —    | F3   |    |
| S26RJ                            | Flanged flush diaphragm (JIS standards)            | 2 in / DN 50                                  | —                      | 3 | 6  | 6  | 8  | —  | —                     | — | 6  | 4  | 6  | 6  | 6  | 6  | 6  | —  | —  | —  | —  | —        | —  | —  | E2   |      |    |
|                                  |  | 3 in / DN 80                                  | 1                      | 4 | 8  | 12 | 12 | —  | —                     | 3 | 8  | 8  | 10 | 10 | 10 | 10 | 10 | —  | —  | —  | —  | —        | —  | —  | E3   |      |    |
|                                  |  | 4 in / DN 100                                 | 1.5                    | 6 | 8  | 16 | 16 | 16 | —                     | 4 | 8  | 10 | 10 | 10 | 10 | 10 | 10 | 10 | 10 | 10 | 10 | 10       | 10 | —  | —    | P3   |    |
|                                  |  | 2 in / DN 50 [fixed]                          | —                      | 3 | 6  | 6  | 8  | 8  | —                     | — | 6  | 3  | 6  | 6  | 6  | 6  | 6  | 6  | 6  | 6  | 6  | 6        | 6  | —  | —    | F1.5 |    |
| S26RH                            | Flanged to ISO 10423 flush diaphragm (API)         | 2 in  | —                      | 3 | 8  | 8  | 8  | 8  | —                     | 2 | 6  | 6  | 8  | 8  | 8  | 8  | 8  | 8  | 8  | 8  | 8  | 8        | 8  | —  | —    | P2   |    |
|                                  |  | 3 in  | 1.5                    | 6 | 8  | 16 | 16 | 16 | —                     | 4 | 10 | 10 | 10 | 10 | 10 | 10 | 10 | 10 | 10 | 10 | 10 | 10       | 10 | —  | —    | P3   |    |
| S26TT                            | Threaded off-line flanged                          | 2 1/2 in                                      | 1                      | 2 | 8  | 12 | 12 | 12 | —                     | 3 | 8  | 8  | 8  | 8  | 8  | 8  | 8  | 8  | 8  | 8  | 8  | 8        | 8  | —  | —    | T2.5 |    |
| S26MA<br>S26ME                   | Off-line flanged (ASME and EN standards)           | 2 1/2 in                                      | 1                      | 2 | 8  | 12 | 12 | 12 | —                     | 3 | 8  | 8  | 8  | 8  | 8  | 8  | 8  | 8  | 8  | 8  | 8  | 8        | 8  | —  | —    | T2.5 |    |
| S26SS                            | Union nut, Triclamp, Sanitary, Aseptic             | 2 in / F 50                                   | —                      | 1 | 3  | 6  | 6  | —  | —                     | 1 | 3  | 3  | 6  | 6  | 6  | 6  | 6  | —  | —  | —  | —  | —        | —  | —  | S2   |      |    |
|                                  |  | 3 in / 4 in / F 80                            | 1.5                    | 6 | 10 | 10 | 10 | —  | —                     | 6 | 10 | 10 | 10 | 10 | 10 | 10 | 10 | 10 | —  | —  | —  | —        | —  | —  | S3   |      |    |
| S26BN                            | Cherry Burrell, Cherry Burrell Aseptic             | 2 in  | —                      | 1 | 3  | 6  | 6  | —  | —                     | 1 | 3  | 3  | 6  | 6  | 6  | 6  | 6  | —  | —  | —  | —  | —        | —  | —  | S2.5 |      |    |
|                                  |  | 3 in / 4 in                                   | 1.5                    | 6 | 10 | 10 | 10 | —  | —                     | 6 | 10 | 10 | 10 | 10 | 10 | 10 | 10 | 10 | —  | —  | —  | —        | —  | —  | S3.5 |      |    |
| S26PN                            | Button type  | 1 in  | —                      | — | —  | —  | —  | —  | —                     | — | —  | —  | —  | —  | —  | —  | 3  | —  | 3  | 3  | —  | —        | —  | B1 |      |      |    |
| S26PN                            | Urea service flanged                               | 1 1/2 in                                      | —                      | — | —  | —  | —  | —  | —                     | — | 5  | 5  | 5  | 5  | 5  | 5  | 5  | 5  | 5  | 5  | 5  | 5        | —  | —  | U1.5 |      |    |
|                                  |  | 2 1/2 in                                      | —                      | 3 | 6  | 6  | 6  | 6  | —                     | 3 | 6  | 6  | 6  | 6  | 6  | 6  | 6  | 6  | 6  | 6  | 6  | 6        | 6  | —  | —    | U2.5 |    |

## Direct mount seals table

The following table shows the types of seals available as direct mount.

According to the combination SEAL/TRANSMITTER SENSOR the table details the compatibility for one direct mount seal construction and the MAXIMUM CAPILLARY LENGTH when a second seal is selected as remote.

The mnemonics will be used as shortest cross references in the following pages of this document.

### 266XRT models

| Seal model                       | Seal type  | Seal diaphragm size (thickness) [flange type] | One direct mount seal |   |   |   |   |   |   | One DM plus one remote seal |   |    |    |    | Mnemonic |       |
|----------------------------------|--|---|-----------------------|---|---|---|---|---|---|-----------------------------|---|----|----|----|----------|-------|
|                                  |  |   | SENSOR                |   |   |   |   |   |   | SENSOR                      |   |    |    |    |          |       |
|                                  |  |   | C                     | F | L | D | N | U | R | V                           | C | F  | L  | N  |          | R     |
| S26FA<br>S26FE<br>S26RA<br>S26RE | Flanged flush diaphragm (ASME and EN standards)                            | DN 25   | -                     | - | Y | Y | - | Y | Y | -                           | - | -  | -  | -  | -        | P1    |
|                                  |  | DN 25 (recessed diaphragm)                    | -                     | - | Y | Y | - | Y | Y | -                           | - | -  | -  | -  | -        | T2    |
|                                  |  | 2 in / DN 50                                  | Y                     | Y | Y | Y | Y | Y | Y | Y                           | - | 3  | 5  | 8  | 8        | P2    |
|                                  |  | 3 in / DN 80                                  | Y                     | Y | Y | Y | Y | Y | Y | Y                           | 3 | 5  | 10 | 10 | 10       | P3    |
|                                  |  | 4 in / DN 100                                 | Y                     | Y | Y | Y | Y | Y | Y | Y                           | 3 | 5  | 10 | 10 | 10       | P3    |
|                                  |  | 1 in / DN 25 (low)                            | -                     | - | Y | Y | Y | Y | Y | -                           | - | -  | 3  | 3  | 3        | F1    |
|                                  |  | 1.5 in / DN 40 (low)                          | -                     | - | Y | Y | Y | Y | Y | -                           | - | -  | 3  | 6  | 6        | F1.5  |
|                                  |  | 2 in / DN 50 (low)                            | Y                     | Y | Y | Y | Y | Y | Y | Y                           | 2 | 4  | 8  | 12 | 16       | F2    |
|                                  | 3 in / DN 80 (low)   | Y   | Y                     | Y | Y | Y | Y | Y | Y | 2                           | 6 | 10 | 16 | 16 | F3       |       |
|                                  | 4 in / DN 100 (low)  | Y   | Y                     | Y | Y | Y | Y | Y | Y | 2                           | 6 | 10 | 16 | 16 | F3       |       |
|                                  | Flanged extended diaphragm (ASME and EN standards)                         | 2 in / DN 50                                  | -                     | - | Y | Y | Y | Y | Y | -                           | - | -  | 4  | 6  | 6        | E2    |
|                                  |  | 3 in / DN 80                                  | Y                     | Y | Y | Y | Y | Y | Y | -                           | 2 | 3  | 8  | 10 | 10       | E3    |
|                                  |  | 4 in / DN 100                                 | Y                     | Y | Y | Y | Y | Y | Y | Y                           | 3 | 5  | 10 | 10 | 10       | P3    |
|                                  |  | 2 in / DN 50 [fixed]                          | -                     | - | Y | Y | Y | Y | Y | -                           | - | -  | 3  | 6  | 6        | F1.5  |
| 3 in / DN 80 [fixed]             |  | Y   | Y                     | Y | Y | Y | Y | Y | - | 2                           | 6 | 10 | 12 | 12 | F2.5     |       |
| 4 in / DN100 [fixed]             |  | Y   | Y                     | Y | Y | Y | Y | Y | - | 2                           | 6 | 10 | 12 | 12 | F2.5     |       |
| S26RJ                            | Flanged flush diaphragm (JIS standards)                                    | A 50  | Y                     | Y | Y | Y | Y | Y | Y | -                           | 3 | 5  | 8  | 8  | P2       |       |
|                                  |  | A 80  | Y                     | Y | Y | Y | Y | Y | Y | 3                           | 5 | 10 | 10 | 10 | P3       |       |
|                                  |  | A 100   | Y                     | Y | Y | Y | Y | Y | Y | 3                           | 5 | 10 | 10 | 10 | P3       |       |
| S26RR                            | Flanged flush diaphragm (Ring Joint ASME standard)                         | 1.5 in  | -                     | - | Y | Y | Y | Y | Y | -                           | - | 3  | 5  | 5  | P1.5     |       |
|                                  |  | 2 in  | Y                     | Y | Y | Y | Y | Y | Y | -                           | 3 | 5  | 8  | 8  | P2       |       |
|                                  |  | 3 in  | Y                     | Y | Y | Y | Y | Y | Y | 3                           | 5 | 10 | 10 | 10 | P3       |       |
| S26TT                            | Threaded off-line flanged  | 2 1/2 in                                      | Y                     | Y | Y | Y | Y | Y | Y | 2                           | 4 | 8  | 8  | 10 | T2.5     |       |
| S26MA<br>S26ME                   | Off-line flanged (ASME and EN standards)                                   | 2 1/2 in                                      | Y                     | Y | Y | Y | Y | Y | Y | 2                           | 4 | 8  | 8  | 10 | T2.5     |       |
| S26SS                            | Union nut, Triclamp, Sanitary, Aseptic                                     | 2 in / F50                                    | -                     | Y | Y | Y | Y | Y | - | -                           | - | 3  | 6  | 6  | S2       |       |
|                                  |  | 3 in / 4 in / F80                             | Y                     | Y | Y | Y | Y | Y | - | 3                           | 4 | 8  | 8  | 8  | S3       |       |
|                                  | Cherry Burrell, Cherry Burrell Aseptic                                     | 2 in  | -                     | Y | Y | Y | Y | Y | - | -                           | - | 3  | 6  | 6  | S2.5     |       |
|                                  |  | 3 in / 4 in                                   | Y                     | Y | Y | Y | Y | Y | - | 3                           | 4 | 8  | 8  | 8  | S3.5     |       |
| S26KN                            | Pulp & Paper application specific (ONLY DIRECT MOUNT WITH 266ART / 266GRT) | 1 in ball valve (266GRT only)                 | -                     | - | Y | Y | - | Y | Y | -                           | - | -  | -  | -  | -        | Y1    |
|                                  |  | 1 in (gasketed)                               | -                     | - | Y | Y | - | Y | Y |                             | - | -  | -  | -  | -        | M1    |
|                                  |  | 1 in (NPT, Gas)                               | -                     | - | Y | Y | - | Y | Y | Y                           | - | -  | -  | -  | -        | M1    |
|                                  |  | 1 1/2 in (gasketed)                           | -                     | Y | Y | Y | - | Y | Y |                             | - | -  | -  | -  | -        | M1.5  |
|                                  |  | 1 1/2 in (NPT - Gas)                          | -                     | Y | Y | Y | - | Y | Y | Y                           | - | -  | -  | -  | -        | M1.5A |
|                                  |  | 1 1/2 in (M44 thread)                         | -                     | Y | Y | Y | - | Y | Y | -                           | - | -  | -  | -  | -        | M1.5B |









## Specification – operative limits

### Fill fluid characteristics

Refer to the following table detailing characteristics of fill fluids when used in transmitters with seal(s) and further limitation for specific models and/or variants.

| Fill fluid (application)                                   | Process temperature and pressure limits |                            |                           |                 | Specifications @ 25 °C (77°F)   |                                 |  |
|--|---|----------------------------|---------------------------|-----------------|---------------------------------|---------------------------------|--|
|  | Tmax °C (°F)<br>@ Pabs<br>> of          | Pmin<br>mbar abs<br>(mmHg) | Tmax<br>°C (°F)<br>@ Pmin | Tmin<br>°C (°F) | Specific<br>gravity<br>(kg/dm3) | Kinematic<br>viscosity<br>(cst) | Thermal<br>expansion<br>(x 10 <sup>-3</sup> /°C) |
| Silicone oil PMX 200 10 cSt                                | 250 (480)<br>@ 385 mbar                 | 0.7<br>(0.5)               | 130<br>(266)              | -40<br>(-40)    | 0.934                           | 10                              | 1.08   |
| Silicone oil Baysilone PD5 5 cSt                           | 250 (480)<br>@ 900 mbar                 | 0.7<br>(0.5)               | 45<br>(113)               | -85<br>(-121)   | 0.923                           | 5                               | 0.98   |
| Inert oil Galden G5 (oxygen service)                       | 160 (320)<br>@ 1 bar                    | 2.1<br>(1.52)              | 60<br>(140)               | -20<br>(-4)     | 1.82                            | 4.4                             | 1.1  |
| Silicone polymer Syltherm XLT (cryogenic service)          | 100 (212)<br>@ 118 mbar                 | 2.1<br>(1.52)              | 20<br>(68)                | -100<br>(-148)  | 0.852                           | 1.4                             | 1  |
| Silicone oil for high temperature (for REMOTE SEAL)        | 375 (707)<br>@ 1 bar                    | 0.7<br>(0.5)               | 220<br>(428)              | -10<br>(14)     | 1.07                            | 39                              | 0.77   |
| Silicone oil for high temperature (for DIRECT MOUNT SEAL)  | 250 (480)<br>@ 3.5 mbar                 | 0.7<br>(0.5)               | 220<br>(428)              | -10<br>(14)     | 1.07                            | 39                              | 0.77   |
| Vegetable oil Neobee M-20 (food - sanitary) FDA approved   | 200 (390)<br>@ 1 bar                    | 10<br>(7.2)                | 20<br>(68)                | -18<br>(0)      | 0.92                            | 9.8                             | 1.2  |
| Mineral oil Esso Marcol 152 (food - sanitary) FDA approved | 250 (480)<br>@ 630 mbar                 | 0.7<br>(0.5)               | 110<br>(230)              | -6<br>(21)      | 0.86                            | 30                              | 0.80   |
| Glycerin Water 70% (food - sanitary) FDA approved          | 93 (200)<br>@ 1 bar                     | 1000<br>(760)              | 93<br>(200)               | -7<br>(20)      | 1.08                            | 2                               | 0.36   |

Absolute viscosity (cP) = Kinematic Viscosity (cSt) x Specific gravity at specified temperature.

The absolute viscosity value is used for response time calculation.

Seals dimensions on following pages are in mm (in).

| Material  | Process temperature limits        |
|---|-----------------------------------|
| Tantalum diaphragm                                | 260 °C (500 °F) max.              |
| PFA anti-stick coating                            | 204 °C (400 °F) max.              |
| PFA anti-corrosion/anti-stick coating             | 250 °C (482 °F) max.              |
| AISI gold plated diaphragm                        | 320 °C (608 °F) max.              |
| PTFE gasket                                       | -100 and 260 °C (-148 and 500 °F) |
| Viton gasket                                      | -20 and 260 °C (-4 and 500 °F)    |
| Graphite gasket                                   | -100 and 360 °C (-148 and 680 °F) |
| Silicone rubber gasket                            | -50 and 204 °C (-58 and 400 °F)   |
| Ethylene Propylene gasket                         | -40 and 149 °C (-40 and 300 °F)   |
| Ethylene Propylene gasket EPDM 3-A 18-03 Class II | -40 and 121 °C (-40 and 250 °F)   |

| Seals model (mnemonic)                                       | Process temperature limits      |
|--|---------------------------------|
| S26KN Pulp & Paper (M1, M1.5 all)                            | -40 and 150 °C (-40 and 302 °F) |
| S26KN Pulp & Paper (Y1)                                      | -20 and 130 °C (-4 and 266 °F)  |
| S26SS with Ethylene Propylene gasket EPDM 3-A 18-03 Class II | -40 and 121 °C (-40 and 250 °F) |
| S26SS with Ethylene Propylene gasket                         | -40 and 149 °C (-40 and 300 °F) |
| S26XX with PFA anti-stick coating                            | max. 204 °C (max 400 °F)        |

### Gasket seat finish for seals

Smooth (polished finish for ASME or EN): 0.8 µm (Ra)

Serrated (to ASME 16.5 flange standard): 3.2 to 6.3 µm (Ra)

Serrated (to EN 1092-1 Type B1): 3.2 to 12.5 µm (Ra)

Serrated (to EN 1092-1 Type D, E and B2): according to standard

### Pressure limits

Overpressure and static upper limit can be derated by the flange rating of seal, as follows:

| Seal model S26RE to EN 1092-1 | Carbon steel flange @ 120 °C | AISI 316 ss flange @ 20 °C |
|-------------------------------|------------------------------|----------------------------|
| PN 16                         | 16 bar                       | 16 bar                     |
| PN 40                         | 40 bar                       | 40 bar                     |
| PN 63                         | 63 bar                       | 63 bar                     |
| PN 100                        | 100 bar                      | 100 bar                    |

| Seal model S26RA and S26RR to ASME B16.5 | Carbon Steel flange @ 100 °F (38 °C) | Dual Grade AISI 316 ss / AISI 316 ss flange @ 100 °F (38 °C) |
|--|--------------------------------------|--|
| Class 150                                | 285 psi                              | 275 psi  |
| Class 300                                | 740 psi                              | 720 psi  |
| Class 600                                | 1480 psi                             | 1440 psi   |
| Class 900                                | 2220 psi                             | 2160 psi   |
| Class 1500                               | 3705 psi                             | 3600 psi   |
| Class 2500                               | 6170 psi                             | 6000 psi   |

| Seal model S26RJ to JIS B 2220 | Carbon steel flange @ 120 °C | AISI 316 ss flange @ 120 °C |
|--------------------------------|------------------------------|-----------------------------|
| 10K                            | 14 bar                       | 14 bar                      |
| 20K                            | 36 bar                       | 36 bar                      |
| 40K                            | 68 bar                       | 68 bar                      |

| Seal model S26RH to ISO1 0423 (API 6A) | AISI 316 ss flange             |                     |
|--|--------------------------------|---------------------|
|  | -29 ... 38 °C (-20 ... 100 °F) | @ 93 °C (200 °F)    |
| API 10000                              | 69.5 MPa, 10000 psi            | 60 MPa, 8687 psi    |
| API 15000                              | 103.5 MPa, 15000 psi           | 89.2 MPa, 12937 psi |

| Seal model S26FE to EN 1092-1 | AISI 316 L ss flange @ 20 °C |
|-------------------------------|------------------------------|
| PN 16                         | 16 bar                       |
| PN 40                         | 40 bar                       |
| PN 63                         | 63 bar                       |
| PN 100                        | 100 bar                      |

| Seal model S26FA to ASME B16.5 | Dual Grade AISI 316 ss flange @ 100 °F (38 °C) |
|--------------------------------|--|
| Class 150                      | 230 psi  |
| Class 300                      | 600 psi  |
| Class 600                      | 1200 psi                                       |

| Seal model S26ME to EN 1092-1 | AISI 316 ss or Hastelloy C flange |
|-------------------------------|-----------------------------------|
| PN 16 / 40                    | 40 bar @ 25 °C (77 °F)            |

| Seal model S26MA to ASME B16.5 | AISI 316 L ss flange @ 25 °C (77 °F) | Hastelloy C flange @ 25 °C (77 °F) |
|--------------------------------|--------------------------------------|------------------------------------|
| Class 150                      | 230 psi                              | 290 psi                            |
| Class 300                      | 600 psi                              | 750 psi                            |

The pressure limit decreases with increasing temperature above to the specified values as defined for the material, respectively for ASME B16.5, EN 1092-1, JIS or ISO 10423 standards.

| Seal model S26TT bolting    | Temperature range              | Pressure limit            |
|-----------------------------|--------------------------------|---------------------------|
| AISI 316 ss or Carbon steel | 0 to 100 °C (32 to 212 °F)     | 21 MPa, 210 bar, 3045 psi |
|                             | -60 to 0 °C (-76 to 32 °F)     | 16 MPa, 160 bar, 2320 psi |
|                             | 100 to 360 °C (212 to 680 °F)  | 16 MPa, 160 bar, 2320 psi |
| Alloy steel                 | 0 to 37.8 °C (32 to 100 °F)    | 21 MPa, 210 bar, 3045 psi |
|                             | -48.3 to 0 °C (-55 to 32 °F)   | 16 MPa, 160 bar, 2320 psi |
|                             | 37.8 to 360 °C (100 to 680 °F) | 13 MPa, 130 bar, 1885 psi |

| Seal model S26SS                   | Pressure limit           |
|------------------------------------|--------------------------|
| Triclamp 2 in                      | 3.8 MPa, 38 bar, 550 psi |
| Triclamp 3 in                      | 2.4 MPa, 24 bar, 350 psi |
| Triclamp 4 in                      | 1.7 MPa, 17 bar, 250 psi |
| Union nut F50                      | 2.5 MPa, 25 bar, 360 psi |
| Union nut F80                      | 2.5 MPa, 25 bar, 360 psi |
| Cherry Burrel 2 in                 | 1.9 MPa, 19 bar, 275 psi |
| Cherry Burrel 3 in                 | 1.9 MPa, 19 bar, 275 psi |
| Cherry Burrel 4 in                 | 1.9 MPa, 19 bar, 275 psi |
| Sanitary flush 4 in                | 1.9 MPa, 19 bar, 275 psi |
| Sanitary extended 4 in             | 1.9 MPa, 19 bar, 275 psi |
| V-band clamp option                | 1 MPa, 10 bar, 145 psi   |
| 4in schedule 5 V-band clamp option | 0.7 MPa, 7 bar, 100 psi  |

| Seal model S26WA to ASME B16.5  |
|---|
| up to 41.37 MPa, 413.7 bar, 6000 psi<br>but not greater than rating of mounting flange (NOT SUPPLIED) |

| Seal model S26WE to EN 1092-1 |                           |
|-------------------------------|---------------------------|
| Form B1                       | 40 MPa, 400 bar, 5800 psi |
| Form D                        | 16 MPa, 160 bar 2320 psi  |
| Form E                        | 10 MPa, 100 bar, 1450 psi |

but not greater than rating of mounting flange (NOT SUPPLIED).

## ...Specification – operative limits

### ...Pressure limits

| <b>Seal model S26BN</b>              |                             |                                      |                       |
|--------------------------------------|-----------------------------|--------------------------------------|-----------------------|
| Types 89, 90 and 92                  | 42 MPa, 420 bar, 6090 psi   |                                      |                       |
| Types 91                             | 35 MPa, 350 bar, 5075 psi   |                                      |                       |
| <b>Seal model S26PN</b>              |                             |                                      |                       |
| 3 in ASME 600 integral flange        | 8 MPa, 80 bar, 1160 psi     |                                      |                       |
| 2 in ASME 2500 threaded flange       | 32 MPa, 320 bar, 4640 psi   |                                      |                       |
| <b>Seal model S26KN</b>              |                             |                                      |                       |
| 1 in seal - sealing with gaskets     | 3 MPa, 30 bar, 435 psi      |                                      |                       |
| 1 1/2 in seals - sealing with gasket | 5 MPa, 50 bar, 725 psi      |                                      |                       |
| 1 in seal with ball valve connection | 4 MPa, 40 bar, 580 psi      |                                      |                       |
| 1 in NPT, 1 1/2 in NPT               | 34.5 MPa, 345 bar, 5000 psi |                                      |                       |
| G 1 in A, G 1 1/2 in A               | 60 MPa, 600 bar, 8700 psi   |                                      |                       |
| <b>Flushing ring gasket material</b> | <b>Process limits</b>       |                                      |                       |
|                                      | <b>Pressure (max.)</b>      | <b>Temperature</b>                   | <b>P x T</b>          |
| Garlock                              | 6.9 MPa, 69 bar, 1000 psi   | -73 and 204 °C<br>(-100 and 400 °F)  | 250000<br>( °F x psi) |
| Graphite                             | 2.5 MPa, 25 bar, 362 psi    | -100 and 380 °C<br>(-148 and 716 °F) |                       |
| PTFE                                 | 6 MPa, 60 bar, 870 psi      | -100 and 250 °C<br>(-148 and 482 °F) |                       |

### Vacuum service for seals

Full vacuum subject to fill fluid limits.

Refer to FILL FLUID CHARACTERISTICS table.

Minimum pressure with seal tantalum diaphragm is 1 kPa abs, 10 mbar abs, 0.15 psia.

## Specification – performance

### Seals temperature effects

The following table shows temperature effect per 20 K (36 °F) change, detailed separately for

- the seal (one element), as process temperature error
- the capillary per meter
- the system (transmitter sensor when combined with a seal of specific size/type, either direct mount or remote) referred to silicone oil (PMX 200) filling and AISI 316 L ss diaphragm materials.

For filling different from silicone oil (PMX 200) the errors can be multiplied by ratio between the thermal expansion coefficients of the selected filling divided by the one of PMX 200, listed in the fill fluid characteristics table.

THE ERRORS IN TABLE CAN BE CONSIDERED DIVIDED BY 4 FOR TRANSMITTERS USING SAME REMOTE SEAL ON THE TWO SIDES.

| S26RA, S26RE, S26RJ rotating flange seal size - Mnemonic | Sensor URL                | Seal error (process) | Direct mount system error (ambient) | Remote mount system error (ambient) | 1 metre capillary error (ambient) |
|--|---------------------------|----------------------|-------------------------------------|-------------------------------------|-----------------------------------|
| 2 in / DN 50 / A50 - P2                                  | ≤40 kPa, 160 inH2O        | 0.23 kPa, 0.92 inH2O | 0.16 kPa, 0.64 inH2O                | 0.14 kPa, 0.56 inH2O                | 0.11 kPa, 0.44 inH2O              |
| 2 in / DN 50 / A50 - P2                                  | ≥160 kPa, 642 inH2O       | 0.23 kPa, 0.92 inH2O | 0.16 kPa, 0.64 inH2O                | 0.14 kPa, 0.56 inH2O                | 0.07 kPa, 0.28 inH2O              |
| 2 in / DN 50 - F2  | ≥ 4 kPa, 16 inH2O         | 0.05 kPa, 0.2 inH2O  | 0.04 kPa, 0.16 inH2O                | 0.04 kPa, 0.16 inH2O                | 0.03 kPa, 0.12 inH2O              |
| 2 in / DN 50 - E2  | ≤40 kPa, 160 inH2O        | 0.25 kPa, 1 inH2O    | 0.21 kPa, 0.84 inH2O                | 0.20 kPa, 0.80 inH2O                | 0.15 kPa, 0.60 inH2O              |
| 2 in / DN 50 - E2  | ≥160 kPa, 642 inH2O       | 0.25 kPa, 1 inH2O    | 0.21 kPa, 0.84 inH2O                | 0.20 kPa, 0.80 inH2O                | 0.10 kPa, 0.40 inH2O              |
| 3 / 4 in / DN 80 / 100 A80 / 100 - P3                    | 4 - 16 kPa, 16 - 64 inH2O | 0.08 kPa, 0.32 inH2O | 0.02 kPa, 0.08 inH2O                | 0.02 kPa, 0.08 inH2O                | 0.02 kPa, 0.08 inH2O              |
| 3 / 4 in / DN 80 / 100 A80 / 100 - P3                    | ≥ 40 kPa, 160 inH2O       | 0.08 kPa, 0.32 inH2O | 0.02 kPa, 0.08 inH2O                | 0.02 kPa, 0.08 inH2O                | 0.03 kPa, 0.12 inH2O              |
| 3 / 4 in / DN 80 / 100 - F3                              | ≥ 4 kPa, 16 inH2O         | 0.02 kPa, 0.08 inH2O | 0.02 kPa, 0.08 inH2O                | 0.02 kPa, 0.08 inH2O                | 0.01 kPa, 0.04 inH2O              |
| 3 in / DN 80 - E3  | ≥ 4 kPa, 16 inH2O         | 0.14 kPa, 0.56 inH2O | 0.05 kPa, 0.20 inH2O                | 0.05 kPa, 0.20 inH2O                | 0.04 kPa, 0.16 inH2O              |
| S26RR rotating flange RJ seal size - Mnemonic            | Sensor URL                | Seal error (process) | Direct mount system error (ambient) | Remote mount system error (ambient) | 1 metre capillary error (ambient) |
| 1 1/2 in - P1.5  | ≥ 160 kPa, 642 inH2O      | 0.74 kPa, 3 inH2O    | 0.67 kPa, 2.68 inH2O                | 0.62 kPa, 2.48 inH2O                | 0.31 kPa, 1.24 inH2O              |
| 2 in - P2  | ≤40 kPa, 160 inH2O        | 0.23 kPa, 0.92 inH2O | 0.16 kPa, 0.64 inH2O                | 0.14 kPa, 0.56 inH2O                | 0.11 kPa, 0.44 inH2O              |
| 2 in - P2  | ≥160 kPa, 642 inH2O       | 0.23 kPa, 0.92 inH2O | 0.16 kPa, 0.64 inH2O                | 0.14 kPa, 0.56 inH2O                | 0.07 kPa, 0.28 inH2O              |
| 3 in - P3  | 4 - 16 kPa, 16 - 64 inH2O | 0.08 kPa, 0.32 inH2O | 0.02 kPa, 0.08 inH2O                | 0.02 kPa, 0.08 inH2O                | 0.02 kPa, 0.08 inH2O              |
| 3 in - P3  | ≥ 40 kPa, 160 inH2O       | 0.08 kPa, 0.32 inH2O | 0.02 kPa, 0.08 inH2O                | 0.02 kPa, 0.08 inH2O                | 0.03 kPa, 0.12 inH2O              |
| S26RH rotating flange ISO seal size - Mnemonic           | Sensor URL                | Seal error (process) | Direct mount system error (ambient) | Remote mount system error (ambient) | 1 metre capillary error (ambient) |
| 1 13/16 in - H1.5  | ≥ 70000 kPa, 10150 psi    | 0.74 kPa, 3 inH2O    | 0.67 kPa, 2.68 inH2O                | 0.62 kPa, 2.48 inH2O                | 0.31 kPa, 1.24 inH2O              |
| 2 1/16 in - P1.5   | ≥ 70000 kPa, 10150 psi    | 0.64 kPa, 2.56 inH2O | 1.25 kPa, 5.0 inH2O                 | 1.14 kPa, 0.08 inH2O                | 0.38 kPa, 1.52 inH2O              |
| S26FA, S26FE fixed flange seal size - Mnemonic           | Sensor URL                | Seal error (process) | Direct mount system error (ambient) | Remote mount system error (ambient) | 1 metre capillary error (ambient) |
| DN25 - T2  | ≥250 kPa, 1000 inH2O      | 0.81 kPa, 3.25 inH2O | 0.50 kPa, 2.01 inH2O                | -                                   | -                                 |
| DN 25 - P1   | ≥250 kPa, 1000 inH2O      | 0.86 kPa, 3.25 inH2O | 0.50 kPa, 2.01 inH2O                | -                                   | -                                 |
| 1 in / DN25 - F1   | ≥250 kPa, 1000 inH2O      | 0.23 kPa, 0.92 inH2O | 1.20 kPa, 4.81 inH2O                | 1.10 kPa, 4.41 inH2O                | 0.55 kPa, 2.20 inH2O              |
| 1.5 in / DN 40 - F1.5                                    | ≤40 kPa, 160 inH2O        | 0.15 kPa, 0.6 inH2O  | 0.17 kPa, 0.68 inH2O                | 0.15 kPa, 0.6 inH2O                 | 0.13 kPa, 0.52 inH2O              |
| 1.5 in / DN 40 - F1.5                                    | ≥ 160 kPa, 642 inH2O      | 0.15 kPa, 0.6 inH2O  | 0.17 kPa, 0.68 inH2O                | 0.15 kPa, 0.6 inH2O                 | 0.08 kPa, 0.32 inH2O              |
| 2 in / DN 50 - P2  | ≤40 kPa, 160 inH2O        | 0.23 kPa, 0.92 inH2O | 0.16 kPa, 0.64 inH2O                | 0.14 kPa, 0.56 inH2O                | 0.11 kPa, 0.44 inH2O              |
| 2 in / DN 50 - P2  | ≥160 kPa, 642 inH2O       | 0.23 kPa, 0.92 inH2O | 0.16 kPa, 0.64 inH2O                | 0.14 kPa, 0.56 inH2O                | 0.07 kPa, 0.28 inH2O              |
| 2 in / DN 50 - F2  | ≥ 4 kPa, 16 inH2O         | 0.05 kPa, 0.2 inH2O  | 0.04 kPa, 0.16 inH2O                | 0.04 kPa, 0.16 inH2O                | 0.03 kPa, 0.12 inH2O              |
| 3 / 4 in / DN 80 / 100 - P3                              | 4 - 16 kPa, 16 - 64 inH2O | 0.08 kPa, 0.32 inH2O | 0.02 kPa, 0.08 inH2O                | 0.02 kPa, 0.08 inH2O                | 0.02 kPa, 0.08 inH2O              |
| 3 / 4 in / DN 80 / 100 - P3                              | ≥ 40 kPa, 160 inH2O       | 0.08 kPa, 0.32 inH2O | 0.02 kPa, 0.08 inH2O                | 0.02 kPa, 0.08 inH2O                | 0.03 kPa, 0.12 inH2O              |
| 3 / 4 in / DN 80 / 100 - F3                              | ≥ 4 kPa, 16 inH2O         | 0.02 kPa, 0.08 inH2O | 0.02 kPa, 0.08 inH2O                | 0.02 kPa, 0.08 inH2O                | 0.01 kPa, 0.04 inH2O              |
| S26MA, S26ME off-line flange seal size - Mnemonic        | Sensor URL                | Seal error (process) | Direct mount system error (ambient) | Remote system error (ambient)       | 1 metre capillary error (ambient) |
| 2 1/2 in - T2.5  | ≥ 4 kPa, 16 inH2O         | 0.26 kPa, 1.04 inH2O | 0.11 kPa, 0.44 inH2O                | 0.1 kPa, 0.4 inH2O                  | 0.08 kPa, 0.32 inH2O              |
| S26TT off-line threaded seal size - Mnemonic             | Sensor URL                | Seal error (process) | Direct mount system error (ambient) | Remote system error (ambient)       | 1 metre capillary error (ambient) |
| 2 1/2 in - T2.5  | ≥ 4 kPa, 16 inH2O         | 0.26 kPa, 1.04 inH2O | 0.11 kPa, 0.44 inH2O                | 0.1 kPa, 0.4 inH2O                  | 0.08 kPa, 0.32 inH2O              |

## ...Specification – performance

### ...Seals temperature effects

| S26SS sanitary and food seal size - Mnemonic | Sensor URL                | Seal error (process) | Direct mount system error (ambient) | Remote system error (ambient) | 1 metre capillary error (ambient) |
|--|---------------------------|----------------------|-------------------------------------|-------------------------------|-----------------------------------|
| 2 in / F50 - S2                              | ≤40 kPa, 160 inH2O        | 0.7 kPa, 2.8 inH2O   | 0.93 kPa, 3.72 inH2O                | 0.87 kPa, 3.48 inH2O          | 0.68 kPa, 2.72 inH2O              |
| 2 in / F50 - S2                              | ≥160 kPa, 642 inH2O       | 0.7 kPa, 2.8 inH2O   | 0.93 kPa, 3.72 inH2O                | 0.87 kPa, 3.48 inH2O          | 0.44 kPa, 1.76 inH2O              |
| 2 in - S2.5                                  | ≤40 kPa, 160 inH2O        | 0.16 kPa, 0.64 inH2O | 0.19 kPa, 0.76 inH2O                | 0.18 kPa, 0.72 inH2O          | 0.14 kPa, 0.56 inH2O              |
| 2 in - S2.5                                  | ≥160 kPa, 642 inH2O       | 0.16 kPa, 0.64 inH2O | 0.19 kPa, 0.76 inH2O                | 0.18 kPa, 0.72 inH2O          | 0.09 kPa, 0.36 inH2O              |
| 3 / 4 in / F80 - S3                          | 4 - 16 kPa, 16 - 64 inH2O | 0.06 kPa, 0.24 inH2O | 0.02 kPa, 0.08 inH2O                | 0.02 kPa, 0.08 inH2O          | 0.01 kPa, 0.04 inH2O              |
| 3 / 4 in / F80 - S3                          | ≥ 40 kPa, 160 inH2O       | 0.06 kPa, 0.24 inH2O | 0.02 kPa, 0.08 inH2O                | 0.02 kPa, 0.08 inH2O          | 0.03 kPa, 0.12 inH2O              |
| 3 / 4 in - S3.5                              | 4 - 16 kPa, 16 - 64 inH2O | 0.04 kPa, 0.16 inH2O | 0.02 kPa, 0.08 inH2O                | 0.02 kPa, 0.08 inH2O          | 0.01 kPa, 0.04 inH2O              |
| 3 / 4 in - S3.5                              | ≥ 40 kPa, 160 inH2O       | 0.04 kPa, 0.16 inH2O | 0.02 kPa, 0.08 inH2O                | 0.02 kPa, 0.08 inH2O          | 0.03 kPa, 0.12 inH2O              |

| S26WA, S26WE wafer seal size - Mnemonic | Sensor URL                | Seal error (process) | Remote mount error (ambient) | 1 metre capillary error (ambient) |
|---|---------------------------|----------------------|------------------------------|-----------------------------------|
| 1 1/2 in / DN 40 - P1.5                 | ≥ 160 kPa, 642 inH2O      | 0.74 kPa, 3 inH2O    | 0.62 kPa, 2.48 inH2O         | 0.31 kPa, 1.24 inH2O              |
| 1 1/2 in / DN 40 - F1.5                 | ≥ 160 kPa, 642 inH2O      | 0.15 kPa, 0.6 inH2O  | 0.15 kPa, 0.6 inH2O          | 0.08 kPa, 0.32 inH2O              |
| 2 in / DN 50 - P2                       | ≤40 kPa, 160 inH2O        | 0.23 kPa, 0.92 inH2O | 0.14 kPa, 0.56 inH2O         | 0.11 kPa, 0.44 inH2O              |
| 2 in / DN 50 - P2                       | ≥160 kPa, 642 inH2O       | 0.23 kPa, 0.92 inH2O | 0.14 kPa, 0.56 inH2O         | 0.07 kPa, 0.28 inH2O              |
| 2 in / DN 50 - F2                       | ≥ 4 kPa, 16 inH2O         | 0.05 kPa, 0.2 inH2O  | 0.04 kPa, 0.16 inH2O         | 0.03 kPa, 0.12 inH2O              |
| 3 in / DN 80 - P3                       | 4 - 16 kPa, 16 - 64 inH2O | 0.08 kPa, 0.32 inH2O | 0.02 kPa, 0.08 inH2O         | 0.02 kPa, 0.08 inH2O              |
| 3 in / DN 80 - P3                       | ≥ 40 kPa, 160 inH2O       | 0.08 kPa, 0.32 inH2O | 0.02 kPa, 0.08 inH2O         | 0.03 kPa, 0.12 inH2O              |
| 3 in / DN 80 - F3                       | ≥ 4 kPa, 16 inH2O         | 0.02 kPa, 0.08 inH2O | 0.02 kPa, 0.08 inH2O         | 0.01 kPa, 0.04 inH2O              |

| S26BN Button type seal size - Mnemonic | Sensor URL        | Seal error (process) | Remote system error (ambient) | 1 metre capillary error (ambient) |
|--|-------------------|----------------------|-------------------------------|-----------------------------------|
| 1 in - B1                              | ≥ 8 MPa, 1160 psi | 1.3 kPa, 5.2 inH2O   | 6.5 kPa, 26 inH2O             | 1.9 kPa, 7.6 inH2O                |

| S26PN urea service seal size - Mnemonic | Sensor URL           | Seal error (process) | Remote system error (ambient) | 1 metre capillary error (ambient) |
|---|----------------------|----------------------|-------------------------------|-----------------------------------|
| 1 1/2 in - U1.5 (2 in flange)           | ≥ 160 kPa, 642 inH2O | 0.86 kPa, 3.44 inH2O | 1.1 kPa, 4.4 inH2O            | 0.54 kPa, 2.16 inH2O              |
| 2 1/2 in - U2.5 (3 in flange)           | ≥ 40 kPa, 160 inH2O  | 0.18 kPa, 0.72 inH2O | 0.06 kPa, 0.24 inH2O          | 0.11 kPa, 0.44 inH2O              |

| S26KN paper seal size - Mnemonic | Sensor URL           | Seal error (process) | Direct mount error (ambient) |
|----------------------------------|----------------------|----------------------|------------------------------|
| 1 in - Y1                        | ≥ 160 kPa, 642 inH2O | 1.2 kPa, 4.8 inH2O   | 0.64 kPa, 2.56 inH2O         |
| 1 in - M1                        | ≥ 160 kPa, 642 inH2O | 0.6 kPa, 2.4 inH2O   | 0.64 kPa, 2.56 inH2O         |
| 1 1/2 in M1.5 - M1.5A - M1.5B    | ≥ 40 kPa, 160 inH2O  | 0.2 kPa, 0.8 inH2O   | 0.48 kPa, 1.92 inH2O         |

## Process and ambient temperature limits

| Direct Mount Models   |            |        |            |            |        |            |
|---|------------|--------|------------|------------|--------|------------|
| Temperature limits referred to P1.5-P2-P3-F1.5-F2-F2.5-F3-E2-E3-S2-S2.5-S3-S3.5-T2.5 Mnemonic type of diaphragm |            |        |            |            |        |            |
|   | 266HRH/NRH | 266DRH | PAD/PGD100 | 266ART/GRT | 266MRT | PGD/PDD300 |
| Minimum Ambient Temperature   | -40°C      | -40°C  | -40°C      | -40°C      | -40°C  | -40°C      |
| Maximum Ambient Temperature   | 85°C       | 85°C   | +85°C      | 85°C       | 85°C   | 85°C       |
| Minimum Process Temperature   | -100°C     | -100°C | -50°C ***  | -100°C     | -100°C | -100°C     |
| Maximum Process Temperature   | 250°C      | 180°C  | +180°C *** | 180°C      | 180°C  | 180°C      |

| Direct Mount Models   |            |               |            |            |               |            |
|---|------------|---------------|------------|------------|---------------|------------|
| Temperature limits referred to P1-F1-Y1-M1-M1.5-M1.5A-M1.5B-T2 Mnemonic type of diaphragm |            |               |            |            |               |            |
|   | 266HRH/NRH | 266DRH        | PAD/PGD100 | 266ART/GRT | 266MRT        | PGD/PDD300 |
| Minimum Ambient Temperature   | -40°C *    | NOT AVAILABLE | -40°C      | -40°C *    | NOT AVAILABLE | -40°C *    |
| Maximum Ambient Temperature   | 85°C       | NOT AVAILABLE | +85°C      | 85°C       | NOT AVAILABLE | 85°C       |
| Minimum Process Temperature****   | -40°C *    | NOT AVAILABLE | -50°C ***  | -40°C *    | NOT AVAILABLE | -40°C *    |
| Maximum Process Temperature****   | 150°C **   | NOT AVAILABLE | +180°C *** | 150°C **   | NOT AVAILABLE | 150°C **   |

\* For Mnemonic type "Y1" minimum process & ambient temperature is -20°C

\*\* For Mnemonic type "Y1" maximum process temperature is 130°C

\*\*\* Upper and lower process temperature limits might vary according to the physical characteristics of the filling fluid and to the different gaskets which the customer decides to install.

\*\*\*\* For Mnemonic type "P1" and "F1" minimum process temperature is -30°C and maximum process temperature is 140°C

### Temperature limits 266MRT

Lower limits (side without seal)

-Refer to lower ambient limits: -20°C for Viton Gasket

Upper limits (side without seal)

-Silicon oil : 121°C (100°C for application below atmospheric pressure)

-Inert fluid : 100°C (65°C for application below atmospheric pressure)

## Model codes

The S26 Series Seal Systems are available with a variety of remote seal constructions identified as follows.

### **IMPORTANT**

Only S26WA, S26WE, S26FA, S26FE, S26RA and S26RE are available with PXD100 models.

- S26FA and S26FE: Fixed-flange seals according to ASME and EN standards
- S26RA, S26RE, S26RH and S26RJ: Rotating-flange seals according to ASME, EN, API and JIS standards
- S26MA and S26ME: Off-line flanged seals according to ASME and EN standards
- S26WA and S26WE: Wafer remote seals according to ASME and EN standards
- S26KN: Pulp & Paper connection seal
- S26RR: Flanged remote seal – Ring Joint construction
- S26SS: Food and sanitary seal
- S26TT: Off-Line threaded connection seal
- S26PN: Remote seal for Urea service
- S26BN: Button type remote seal

The S26 Series Seal Systems are used on the following transmitters:

- 266xR / 266xD / PxD100 / PxD300 (where x means “any letter”)

Differential pressure transmitters have one or two remote seals. Single sided differential pressure transmitters have a single remote seal for tank level applications.

Gauge and absolute pressure transmitters have a single remote seal.

The transmitter and seal system are identified by product code numbers which are stamped on the transmitter nameplate. An example of the product code stamping is as follows:

| Transmitter Product Code | Seal System Product Code |
|--------------------------|--------------------------|
| 266DRHGSRRAH             | S26WAHD5FSM2AASNNN       |
| PGD100LS9A1RRYUA         | S26FAHE2SFSM1N1SNNN      |
| PGD300LS9R1RRYAHD1       | S26RAHE1CFSM1BASNNN      |

The characters which comprise these code numbers identify specific product features. A detailed explanation of the code numbers together with physical and performance specifications for both the transmitter and seal system is provided in the product specification sheets.



## Diaphragm seal models

### Wafer Remote Seal (S26WA and S26WE)

The wafer remote seal is designed to be clamped between two ASME (S26WA) or EN raised face flanges (S26WE). The diaphragm side of the seal faces the process flange and a back-up flange is used on the other side of the seal. The S26WA wafer seals can be used with: ANSI CL150, CL300, CL600, CL900 or CL1500 flanges whereas the S26WE with EN DN 10-40, DN64-160.

For mounting dimensions for the wafer remote seal are listed in this chapter. The required back-up flange can be supplied by the user, or it can be obtained as an option with the seal system. Bolts, nuts, and a flange gasket must be supplied by the user.

### IMPORTANT

In case of DP style transmitter with one remote seal, please refer to "Liquid Level Measurement" Section.

Model S26WA (manufactured according to ASME B16.5) is characterized by a maximum working pressure up to 41.37 MPa (413.7 bar or 6000 psi). Model S26WE (manufactured according to EN 1092-1) can have different pressure limits because of the relevant forms:

- Form B1 up to 40 MPa (400 bar or 5800 psi)
- Form D up to 16 MPa (160 bar or 2320 psi)
- Form E up to 10 MPa (100 bar or 1450 psi)

Connect the seal element as follows:

1. Remove protective covering from seal.
2. Install a gasket between the flange and the seal surface.
3. Clamp the seal between two flanges. Be sure that the gasket is properly positioned between the process flange and the seal element gasket surface.
4. Tighten bolts firmly and uniformly in accordance with standard industrial flange bolting practices.

For vacuum service recommendations, temperature limits, gasket finish, temperature effects and configuration, please refer to product datasheet.



Figure 1: Wafer / Pancake style remote seal

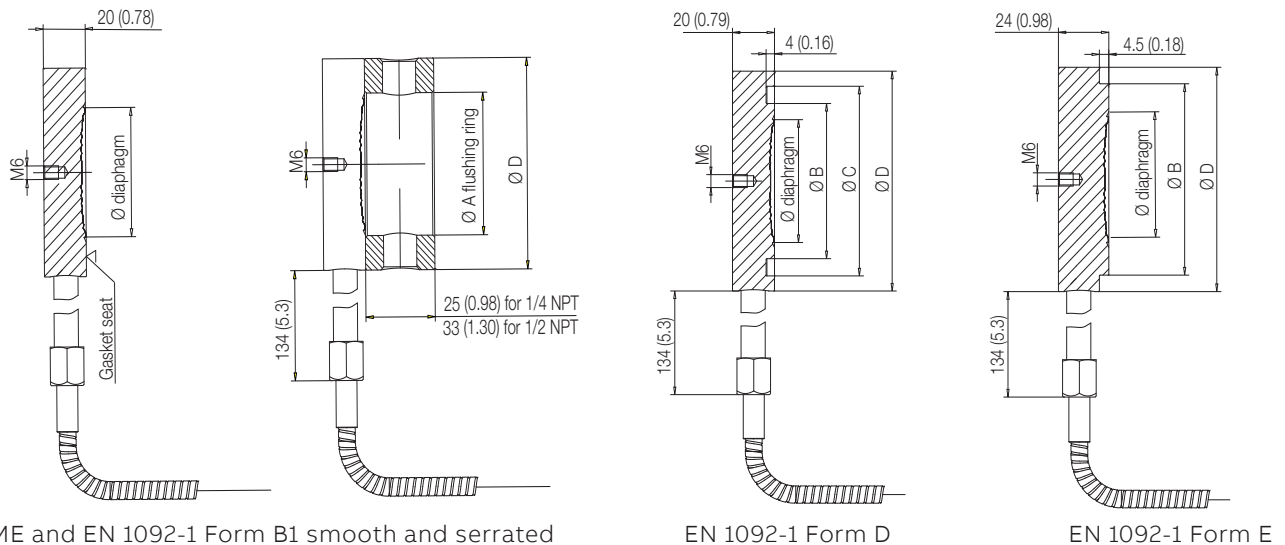

| Size/Rating             | Dimensions mm (in) for S26W |               |                              |            |            |            |
|-------------------------|-----------------------------|---------------|------------------------------|------------|------------|------------|
|                         | diaphragm (dia)             |               | A flushing ring internal dia | B (dia)    | C (dia)    | D (dia)    |
|                         | std. thickness              | low thickness |                              |            |            |            |
| 1 1/2 in. ASME B16.5    | 47 (1.85)                   | 47 (1.85)     | 52 (2.05)                    | NA         | NA         | 73 (2.87)  |
| 2 in. ASME B16.5        | 60 (2.36)                   | 58 (2.28)     | 62 (2.44)                    | NA         | NA         | 92 (3.62)  |
| 3 in. ASME B16.5        | 89 (3.5)                    | 75 (2.95)     | 92 (3.62)                    | NA         | NA         | 127 (5)    |
| DN 40 EN 1092-1 Form B1 | 47 (1.85)                   | 47 (1.85)     | 52 (2.05)                    | NA         | NA         | 88 (3.46)  |
| DN 50 EN 1092-1 Form B1 | 60 (2.36)                   | 58 (2.28)     | 62 (2.44)                    | NA         | NA         | 102 (4.02) |
| DN 80 EN 1092-1 Form B1 | 89 (3.5)                    | 75 (2.95)     | 92 (3.62)                    | NA         | NA         | 138 (5.43) |
| DN 40 EN 1092-1 Form D  | 47 (1.85)                   | 47 (1.85)     | NA                           | 60 (2.36)  | 76 (2.99)  | 88 (3.46)  |
| DN 50 EN 1092-1 Form D  | 60 (2.36)                   | 58 (2.28)     | NA                           | 72 (2.83)  | 88 (3.46)  | 102 (4.02) |
| DN 80 EN 1092-1 Form D  | 89 (3.5)                    | 75 (2.95)     | NA                           | 105 (4.13) | 121 (4.76) | 138 (5.43) |
| DN 40 EN 1092-1 Form E  | 47 (1.85)                   | 47 (1.85)     | NA                           | 75 (2.95)  | NA         | 88 (3.46)  |
| DN 50 EN 1092-1 Form E  | 60 (2.36)                   | 58 (2.28)     | NA                           | 87 (3.42)  | NA         | 102 (4.02) |
| DN 80 EN 1092-1 Form E  | 89 (3.5)                    | 75 (2.95)     | NA                           | 120 (4.72) | NA         | 138 (5.43) |

**Rotating flange diaphragm seals – flush and extended (S26RA, S26RE, S26RH and S26RJ)**

The extended and flush diaphragm remote seal is designed to connect to flanged pipe fitting, according to ASME B16.5 (S26RA), EN 1092-1 (S26RE), JIS B 2220 standards (S26RJ) or ISO 10423 (S26RH).

For liquid level measurement installations the seal connects to a flanged tank nozzle, compliant to the relevant standard.

The sealing is provided by a selectable smooth or serrated gasket seat surface finish. The mounting flange is of rotating type and can be supplied on carbon steel or in stainless steel AISI 316 (Dual Grade AISI 316 ss for S26RA).

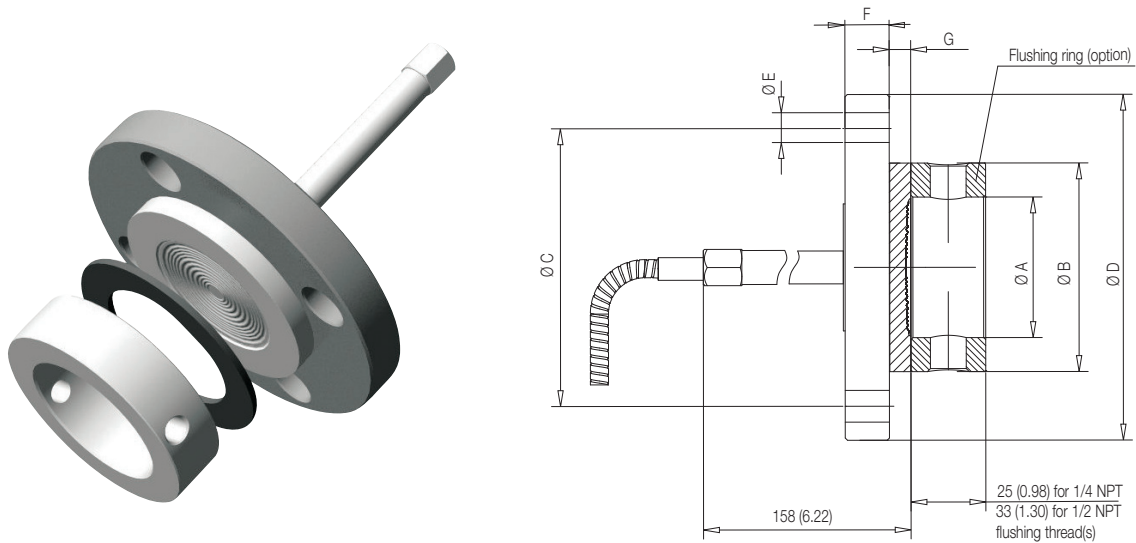

Figure 2: Flush rotating-flange seals (flushing ring as an option)

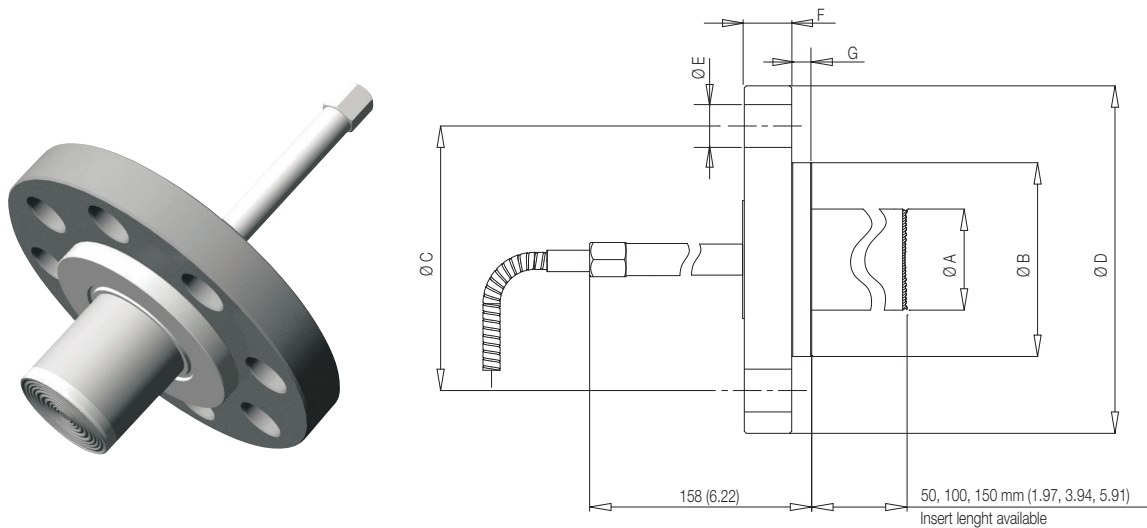

Figure 3: Extended rotating-flange seals

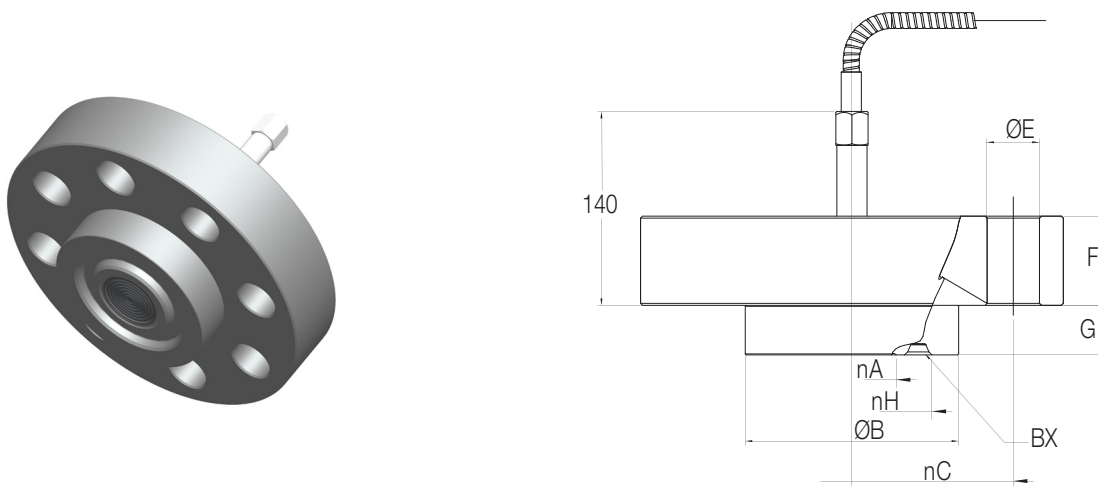

Figure 4: Flush rotating-flange (API) ring-joint construction

| Size/Rating        | Dimensions mm (in) for S26RA |                         |                               |                               |             |               |              |              |               |            |                |
|--------------------|------------------------------|-------------------------|-------------------------------|-------------------------------|-------------|---------------|--------------|--------------|---------------|------------|----------------|
|                    | A (dia)                      |                         |                               |                               | B (dia)     | C (dia)       | D (dia)      | E (dia)      | F<br>(Note 1) | G          | N° of<br>holes |
|                    | extended<br>diaphragm        | flush diaphragm<br>std. | flush diaphragm<br>low thick. | flushing ring<br>internal dia |             |               |              |              |               |            |                |
| 2 in. ASME CL 150  | 48 (1.9)                     | 60 (2.36)               | 58 (2.28)                     | 62 (2.44)                     | 92 (3.62)   | 120.65 (4.75) | 152.4 (6)    | 19.1 (0.79)  | 17.5 (0.6)    | 9.5 (0.37) | 4              |
| 2 in. ASME CL 300  | 48 (1.9)                     | 60 (2.36)               | 58 (2.28)                     | 62 (2.44)                     | 92 (3.62)   | 127 (5)       | 165.1 (6.5)  | 19.1 (0.79)  | 20.8 (0.8)    | 9.5 (0.37) | 8              |
| 2 in. ASME CL 600  | NA                           | 60 (2.36)               | 58 (2.28)                     | 62 (2.44)                     | 92 (3.62)   | 127 (5)       | 165.1 (6.5)  | 19.1 (0.79)  | 25.4 (1)      | 9.5 (0.37) | 8              |
| 2 in. ASME CL 900  | NA                           | 60 (2.36)               | 58 (2.28)                     | 62 (2.44)                     | 92 (3.62)   | 165 (6.5)     | 215.9 (8.5)  | 26 (1.02)    | 38.1 (1.5)    | 9.5 (0.37) | 8              |
| 2 in. ASME CL 1500 | NA                           | 60 (2.36)               | 58 (2.28)                     | 62 (2.44)                     | 92 (3.62)   | 165 (6.5)     | 215.9 (8.5)  | 26 (1.02)    | 38.1 (1.5)    | 9.5 (0.37) | 8              |
| 3 in. ASME CL 150  | 72 (2.83)                    | 89 (3.5)                | 75 (2.95)                     | 92 (3.62)                     | 127 (5)     | 152.4 (6)     | 190.5 (7.5)  | 19.1 (0.79)  | 22.4 (0.88)   | 9.5 (0.37) | 4              |
| 3 in. ASME CL 300  | 72 (2.83)                    | 89 (3.5)                | 75 (2.95)                     | 92 (3.62)                     | 127 (5)     | 168.15 (6.62) | 209.6 (8.25) | 22.4 (0.88)  | 26.9 (1.1)    | 9.5 (0.37) | 8              |
| 3 in. ASME CL 600  | NA                           | 89 (3.5)                | 75 (2.95)                     | 92 (3.62)                     | 127 (5)     | 168.15 (6.62) | 209.6 (8.25) | 22.4 (0.88)  | 31.8 (1.3)    | 9.5 (0.37) | 8              |
| 3 in. ASME CL 900  | NA                           | 89 (3.5)                | 75 (2.95)                     | 92 (3.62)                     | 127 (5)     | 190.5 (7.5)   | 241 (9.48)   | 26 (1.02)    | 38.1 (1.5)    | 9.5 (0.37) | 8              |
| 3 in. ASME CL1500  | NA                           | 89 (3.5)                | 75 (2.95)                     | 92 (3.62)                     | 127 (5)     | 203.2 (8)     | 266.7 (10.5) | 31.75 (1.25) | 47.7 (1.88)   | 9.5 (0.37) | 8              |
| 4 in. ASME CL 150  | 94 (3.7)                     | 89 (3.5)                | 75 (2.95)                     | 92 (3.62)                     | 157.2 (6.2) | 190.5 (7.5)   | 228.6 (9)    | 19.1 (0.79)  | 22.4 (0.88)   | 9.5 (0.37) | 8              |
| 4 in. ASME CL 300  | 94 (3.7)                     | 89 (3.5)                | 75 (2.95)                     | 92 (3.62)                     | 157.2 (6.2) | 200.2 (7.88)  | 254 (10)     | 22 (0.86)    | 30.2 (1.19)   | 9.5 (0.37) | 8              |

| Size/Rating     | Dimensions mm (in) for S26RE |                         |                               |                               |            |            |            |           |               |            |                |
|-----------------|------------------------------|-------------------------|-------------------------------|-------------------------------|------------|------------|------------|-----------|---------------|------------|----------------|
|                 | A (dia)                      |                         |                               |                               | B (dia)    | C (dia)    | D (dia)    | E (dia)   | F<br>(Note 2) | G          | N° of<br>holes |
|                 | extended<br>diaphragm        | flush diaphragm<br>std. | flush diaphragm<br>low thick. | flushing ring<br>internal dia |            |            |            |           |               |            |                |
| DN 50 EN PN 16  | 48 (1.9)                     | 60 (2.36)               | 58 (2.28)                     | 62 (2.44)                     | 102 (4.02) | 125 (4.92) | 165 (6.5)  | 18 (0.71) | 15 (0.58)     | 9.5 (0.37) | 4              |
| DN 50 EN PN 40  | 48 (1.9)                     | 60 (2.36)               | 58 (2.28)                     | 62 (2.44)                     | 102 (4.02) | 125 (4.92) | 165 (6.5)  | 18 (0.71) | 18 (0.71)     | 9.5 (0.37) | 4              |
| DN 50 EN PN 63  | NA                           | 60 (2.36)               | 58 (2.28)                     | 62 (2.44)                     | 102 (4.02) | 135 (5.31) | 180 (7.08) | 22 (0.86) | 23 (0.9)      | 9.5 (0.37) | 4              |
| DN 50 EN PN 100 | NA                           | 60 (2.36)               | 58 (2.28)                     | 62 (2.44)                     | 102 (4.02) | 145 (5.71) | 195 (7.67) | 26 (1.02) | 27 (1.06)     | 9.5 (0.37) | 4              |
| DN 80 EN PN 16  | 72 (2.83)                    | 89 (3.5)                | 75 (2.95)                     | 92 (3.62)                     | 138 (5.43) | 160 (6.3)  | 200 (7.87) | 18 (0.71) | 17 (0.67)     | 9.5 (0.37) | 8              |
| DN 80 EN PN 40  | 72 (2.83)                    | 89 (3.5)                | 75 (2.95)                     | 92 (3.62)                     | 138 (5.43) | 160 (6.3)  | 200 (7.87) | 18 (0.71) | 21 (0.83)     | 9.5 (0.37) | 8              |
| DN 80 EN PN 63  | NA                           | 89 (3.5)                | 75 (2.95)                     | 92 (3.62)                     | 138 (5.43) | 170 (6.7)  | 215 (8.46) | 22 (0.86) | 25 (0.98)     | 9.5 (0.37) | 8              |
| DN 80 EN PN 100 | NA                           | 89 (3.5)                | 75 (2.95)                     | 92 (3.62)                     | 138 (5.43) | 180 (7.08) | 230 (9.05) | 26 (1.02) | 33 (1.3)      | 9.5 (0.37) | 8              |
| DN 100 EN PN 16 | 94 (3.7)                     | 89 (3.5)                | 75 (2.95)                     | 92 (3.62)                     | 158 (6.22) | 180 (7.08) | 220 (8.66) | 18 (0.71) | 17 (0.67)     | 9.5 (0.37) | 8              |
| DN 100 EN PN 40 | 94 (3.7)                     | 89 (3.5)                | 75 (2.95)                     | 92 (3.62)                     | 162 (6.38) | 190 (7.48) | 235 (9.25) | 22 (0.86) | 21 (0.83)     | 9.5 (0.37) | 8              |

| Size/Rating    | Dimensions mm (in) for S26RJ |              |            |            |           |               |            |                |  |
|----------------|------------------------------|--------------|------------|------------|-----------|---------------|------------|----------------|--|
|                | A (dia)<br>flush diaphragm   | B (dia)      | C (dia)    | D (dia)    | E (dia)   | F<br>(Note 3) | G          | N° of<br>holes |  |
| A50 Class 10K  | 60 (2.36)                    | 96 (3.78)    | 120 (4.72) | 155 (6.1)  | 19 (0.75) | 16 (0.63)     | 9.5 (0.37) | 4              |  |
| A50 Class 20K  | 60 (2.36)                    | 96 (3.78)    | 120 (4.72) | 155 (6.1)  | 19 (0.75) | 18 (0.71)     | 9.5 (0.37) | 8              |  |
| A50 Class 40K  | 60 (2.36)                    | 104.3 (4.11) | 130 (5.12) | 165 (6.5)  | 19 (0.75) | 26 (1.02)     | 9.5 (0.37) | 8              |  |
| A80 Class 10K  | 89 (3.5)                     | 126 (4.96)   | 150 (5.91) | 185 (7.28) | 19 (0.75) | 18 (0.71)     | 9.5 (0.37) | 8              |  |
| A80 Class 20K  | 89 (3.5)                     | 132 (5.2)    | 160 (6.3)  | 200 (7.87) | 23 (0.91) | 22 (0.87)     | 9.5 (0.37) | 8              |  |
| A80 Class 40K  | 89 (3.5)                     | 139.4 (5.49) | 170 (6.69) | 210 (8.27) | 23 (0.91) | 32 (1.26)     | 9.5 (0.37) | 8              |  |
| A100 Class 10K | 89 (3.5)                     | 151 (5.94)   | 175 (6.89) | 210 (8.27) | 19 (0.75) | 18 (0.71)     | 9.5 (0.37) | 8              |  |
| A100 Class 20K | 89 (3.5)                     | 160 (6.3)    | 185 (7.28) | 225 (8.86) | 23 (0.91) | 24 (0.94)     | 9.5 (0.37) | 8              |  |

| Size/Rating           | Dimensions mm. (in.) for S26RH |              |              |            |           |             |           |              |        |                |
|-----------------------|--------------------------------|--------------|--------------|------------|-----------|-------------|-----------|--------------|--------|----------------|
|                       | A (dia)                        | B (dia)      | C (dia)      | D (dia)    | E (dia)   | F           | G         | H (dia)      | BX     | N° of<br>holes |
| 1 13/16 in. API 10000 | 40 (1.57)                      | 105.5 (4.15) | 146.1 (5.75) | 185 (7.28) | 23 (0.91) | 42.1 (1.66) | 25 (0.98) | 77.77 (3.06) | BX 151 | 8              |
| 1 13/16 in. API 15000 | 40 (1.57)                      | 105.5 (4.15) | 160.3 (6.31) | 210 (8.27) | 26 (1.02) | 45 (1.77)   | 25 (0.98) | 77.77 (3.06) | BX 151 | 8              |
| 2 1/16 in. API 10000  | 50 (1.97)                      | 112.5 (4.43) | 158.8 (6.25) | 200 (7.87) | 23 (0.91) | 44.1 (1.74) | 25 (0.98) | 86.23 (3.40) | BX 152 | 8              |
| 2 1/16 in. API 15000  | 50 (1.97)                      | 112.5 (4.43) | 174.6 (6.87) | 220 (8.66) | 26 (1.02) | 50.8 (2.00) | 25 (0.98) | 86.23 (3.40) | BX 152 | 8              |

Note 1 - Flange thickness tolerance is +3.0 / -0.0 mm (+0.12 / 0.0 in.).

Note 2 - Flange thickness tolerance is +1.0 / -1.3 mm (+0.04 / 0.05 in.) up to 18 mm or ±1.5 mm (±0.06 in.) from 18 to 50 mm from 18 to 50 mm.

Note 3 - Flange thickness tolerance is +1.5 / -0.0 mm (+0.06 / 0.0 in.) up to Class 20K or +2.0 / -0.0 mm (+0.08 / 0.0 in.) from Class 20K to Class 50K.

**Rotating flange diaphragm seal - Ring Joint (S26RR)**

The flanged flush diaphragm remote seal – ring joint is designed to connect to ASME flanged pipe fitting. For liquid level measurement installations the seal connects to a flanged tank nozzle, compliant to the relevant standard. The mounting flange is of rotating type and can be supplied on carbon steel or in stainless steel AISI 316. The sealing is provided by a user-supplied gasket which must be installed between the process and seal gasket seat.

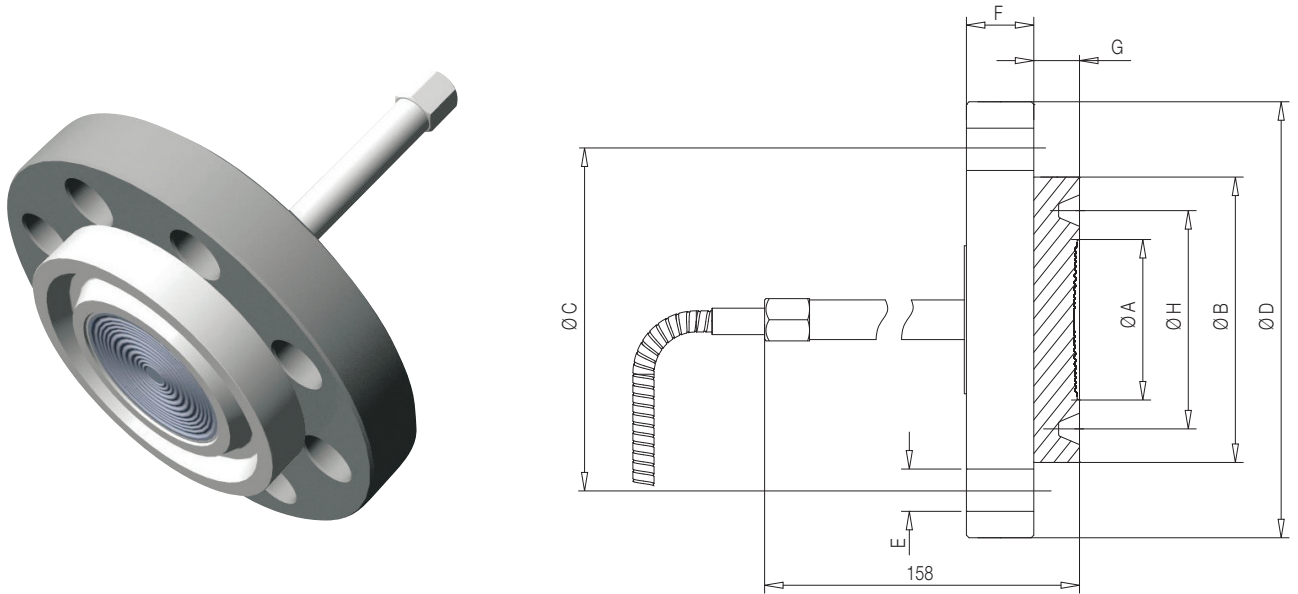

Figure 5: Ring-joint diaphragm seal

| Size/Rating                | Dimensions mm (in) for S26RR |            |               |               |              |              |             |              |     |             |
|----------------------------|------------------------------|------------|---------------|---------------|--------------|--------------|-------------|--------------|-----|-------------|
|                            | A (dia)                      | B (dia)    | C (dia)       | D (dia)       | E (dia)      | F            | G           | H (dia)      | R   | N° of holes |
| 1-1/2 in. ASME CL 150      | 48 (1.89)                    | 83 (3.27)  | 98.6 (3.88)   | 127 (5)       | 15.75 (0.62) | 17.5 (0.69)  | 17.3 (0.68) | 65.1 (2.56)  | R19 | 4           |
| 1-1/2 in. ASME CL 300      | 48 (1.89)                    | 90 (3.54)  | 114.3 (4.5)   | 155.5 (6.12)  | 22.35 (0.88) | 20.6 (0.81)  | 17.3 (0.68) | 68.3 (2.69)  | R20 | 4           |
| 1-1/2 in. ASME CL 600      | 48 (1.89)                    | 90 (3.54)  | 114.3 (4.5)   | 155.5 (6.12)  | 22.35 (0.88) | 22.4 (0.88)  | 17.3 (0.68) | 68.3 (2.69)  | R20 | 4           |
| 1-1/2 in. ASME CL 900/1500 | 48 (1.89)                    | 92 (3.62)  | 124 (4.88)    | 177.8 (7)     | 28.45 (1.12) | 31.8 (1.25)  | 20.8 (0.82) | 68.3 (2.69)  | R20 | 4           |
| 1-1/2 in. ASME CL 2500     | 48 (1.89)                    | 114 (4.49) | 146.1 (5.75)  | 203.2 (8)     | 31.75 (1.25) | 44.5 (1.75)  | 20.8 (0.82) | 82.6 (3.25)  | R23 | 4           |
| 2 in. ASME CL 150          | 60 (2.36)                    | 102 (4.02) | 120.65 (4.75) | 152.4 (6)     | 19.05 (0.75) | 19.05 (0.75) | 17.3 (0.68) | 82.6 (3.25)  | R22 | 4           |
| 2 in. ASME CL 300          | 60 (2.36)                    | 108 (4.25) | 127 (5)       | 165.1 (6.5)   | 19.05 (0.75) | 22.35 (0.88) | 17.3 (0.68) | 82.6 (3.25)  | R23 | 8           |
| 2 in. ASME CL 600          | 60 (2.36)                    | 108 (4.25) | 127 (5)       | 165.1 (6.5)   | 19.05 (0.75) | 25.4 (1)     | 17.3 (0.68) | 82.6 (3.25)  | R23 | 8           |
| 2 in. ASME CL 900/1500     | 60 (2.36)                    | 124 (4.88) | 165 (6.5)     | 215.9 (8.5)   | 25.4 (1)     | 38.1 (1.5)   | 20.8 (0.82) | 95.3 (3.75)  | R24 | 8           |
| 2 in. ASME CL 2500         | 60 (2.36)                    | 133 (5.24) | 171.5 (6.75)  | 235 (9.25)    | 28.45 (1.12) | 50.8 (2)     | 20.8 (0.82) | 101.6 (4)    | R26 | 8           |
| 3 in. ASME CL 150          | 89 (3.5)                     | 133 (5.24) | 152.4 (6)     | 190.5 (7.5)   | 19.05 (0.75) | 23.87 (0.94) | 17.3 (0.68) | 114.3 (4.5)  | R29 | 4           |
| 3 in. ASME CL 300          | 89 (3.5)                     | 146 (5.75) | 168.15 (6.62) | 209.55 (8.25) | 22.35 (0.88) | 28.44 (1.12) | 17.3 (0.68) | 123.8 (4.87) | R31 | 8           |
| 3 in. ASME CL 600          | 89 (3.5)                     | 146 (5.75) | 168.15 (6.62) | 209.55 (8.25) | 22.35 (0.88) | 31.75 (1.25) | 17.3 (0.68) | 123.8 (4.87) | R31 | 8           |
| 3 in. ASME CL 900          | 89 (3.5)                     | 155 (6.10) | 190.5 (7.5)   | 241.3 (9.5)   | 25.4 (1)     | 38.1 (1.50)  | 20.8 (0.82) | 123.8 (4.87) | R31 | 8           |
| 3 in. ASME CL 1500         | 89 (3.5)                     | 168 (6.61) | 203.2 (8)     | 266.7 (10.5)  | 31.75 (1.25) | 47.8 (1.88)  | 20.8 (0.82) | 136.5 (5.37) | R35 | 8           |
| 3 in. ASME CL 2500         | 89 (3.5)                     | 168 (6.61) | 228.6 (9)     | 304.8 (12)    | 35.05 (1.38) | 66.5 (2.62)  | 20.8 (0.82) | 127 (5)      | R32 | 8           |

For any other detailed information regarding S26RR seal such as pressure limits, vacuum service recommendations, process temperature limits, temperature effects and configuration, please refer to product datasheet.

**Fixed flange diaphragm seals – flush and extended (S26FA, S26FE)**

These diaphragm seal are designed to connect to flanged pipe fitting, according to ASME or EN standards. For liquid level measurement installations, the seal connects to a flanged tank nozzle, compliant to relevant standard. The sealing is provided by a selectable gasket seat surface finish. The “fixed” mounting flange is integral with the seal.

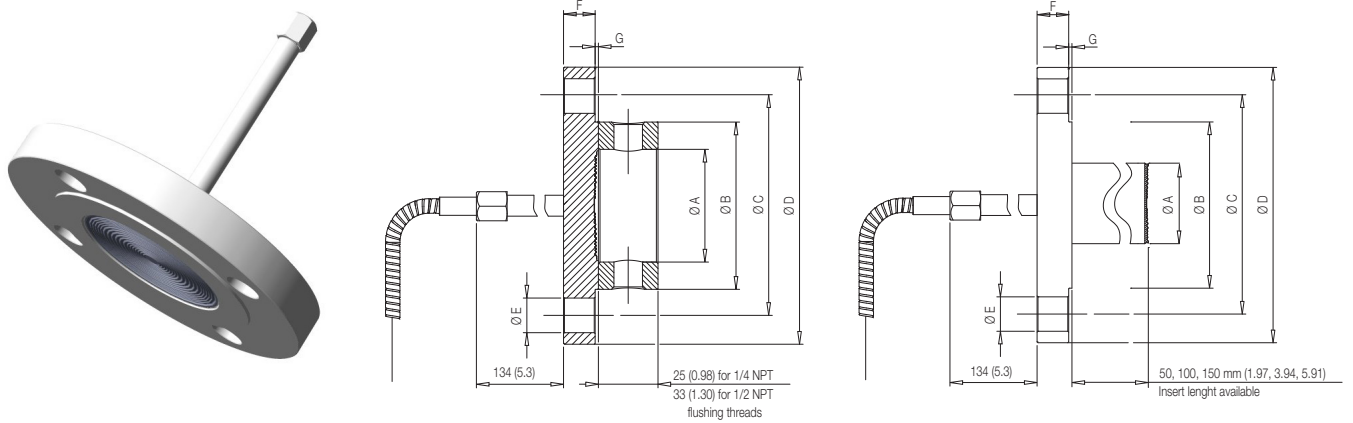
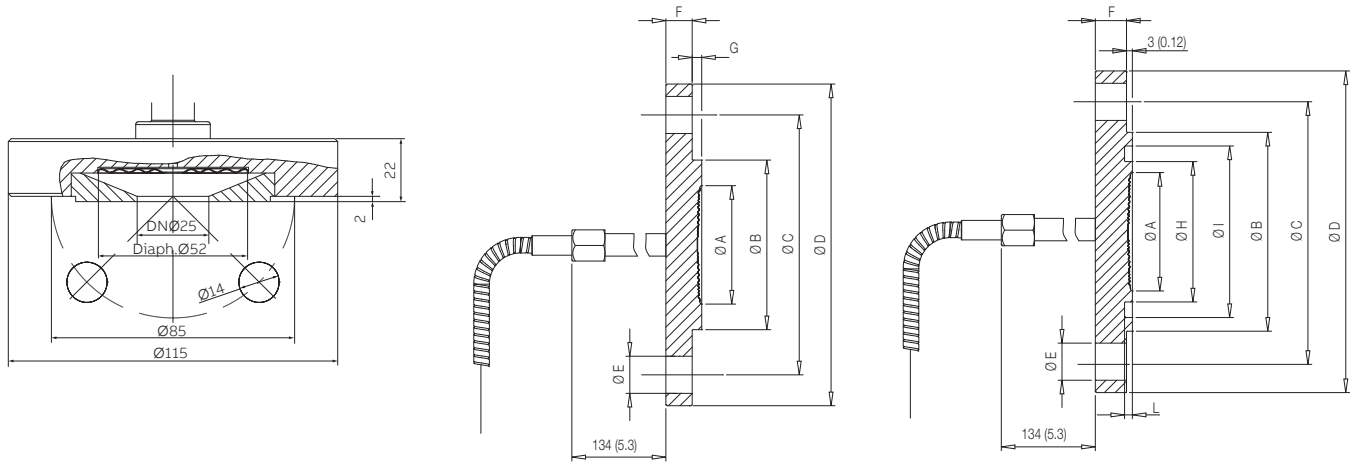

Figure 6: Fixed-flange diaphragm seal ASME and EN 1092-1 smooth and Form B1 (flushing ring as option, only for flush version)



EN 1092-1 Form B1 (Recessed Diaphragm)

EN 1092-1 Form E

EN 1092-1 Form D

**Dimensions mm (in) for S26FA**

| Size/Rating         | A (dia)            |                 |             |                            |             |               |              |             |             |          | N° of holes |
|---------------------|--------------------|-----------------|-------------|----------------------------|-------------|---------------|--------------|-------------|-------------|----------|-------------|
|                     | extended diaphragm | flush diaphragm |             | flushing ring internal dia | B (dia)     | C (dia)       | D (dia)      | E (dia)     | F (Note 1)  | G        |             |
|                     |                    | std.            | low thick.  |                            |             |               |              |             |             |          |             |
| 1 in. ASME CL 150   | -                  | -               | 32 (1.3)    | 27 (1.07)                  | 50.8 (2)    | 79.2 (3.12)   | 108 (4.25)   | 16 (0.63)   | 12.7 (0.5)  | 2 (0.08) | 4           |
| 1 in. ASME CL 300   | -                  | -               | 32 (1.3)    | 27 (1.07)                  | 50.8 (2)    | 88.9 (3.5)    | 124 (4.88)   | 19 (0.75)   | 15.7 (0.62) | 2 (0.08) | 4           |
| 1 in. ASME CL 600   | -                  | -               | 32 (1.3)    | 27 (1.07)                  | 50.8 (2)    | 88.9 (3.5)    | 124 (4.88)   | 19 (0.75)   | 17.5 (0.69) | 7 (0.3)  | 4           |
| 1.5 in. ASME CL 150 | -                  | -               | 47.7 (1.88) | 52 (2.04)                  | 73 (2.87)   | 98.6 (3.89)   | 127 (5)      | 16 (0.63)   | 15.9 (0.62) | 2 (0.08) | 4           |
| 1.5 in. ASME CL 300 | -                  | -               | 47.7 (1.88) | 52 (2.04)                  | 73 (2.87)   | 114.3 (4.5)   | 155 (6.10)   | 22 (0.875)  | 19 (0.75)   | 2 (0.08) | 4           |
| 1.5 in. ASME CL 600 | -                  | -               | 47.7 (1.88) | 52 (2.04)                  | 73 (2.87)   | 114.3 (4.5)   | 155 (6.10)   | 22 (0.875)  | 22.4 (0.88) | 7 (0.3)  | 4           |
| 2 in. ASME CL 150   | 48 (1.9)           | 60 (2.36)       | 58 (2.28)   | 62 (2.44)                  | 92 (3.62)   | 120.65 (4.75) | 152.4 (6)    | 19.1 (0.79) | 17.5 (0.6)  | 2 (0.08) | 4           |
| 2 in. ASME CL 300   | 48 (1.9)           | 60 (2.36)       | 58 (2.28)   | 62 (2.44)                  | 92 (3.62)   | 127 (5)       | 165.1 (6.5)  | 19.1 (0.79) | 20.8 (0.8)  | 2 (0.08) | 8           |
| 2 in. ASME CL 600   | 48 (1.9)           | 60 (2.36)       | 58 (2.28)   | 62 (2.44)                  | 92 (3.62)   | 127 (5)       | 165.1 (6.5)  | 19.1 (0.79) | 25.4 (1)    | 7 (0.27) | 8           |
| 3 in. ASME CL 150   | 72 (2.83)          | 89 (3.5)        | 75 (2.95)   | 92 (3.62)                  | 127 (5)     | 152.4 (6)     | 190.5 (7.5)  | 19.1 (0.79) | 22.4 (0.88) | 2 (0.08) | 4           |
| 3 in. ASME CL 300   | 72 (2.83)          | 89 (3.5)        | 75 (2.95)   | 92 (3.62)                  | 127 (5)     | 168.15 (6.62) | 209.6 (8.25) | 22.4 (0.86) | 26.9 (1.1)  | 2 (0.08) | 8           |
| 3 in. ASME CL 600   | 72 (2.83)          | 89 (3.5)        | 75 (2.95)   | 92 (3.62)                  | 127 (5)     | 168.15 (6.62) | 209.6 (8.25) | 22.4 (0.86) | 31.8 (1.3)  | 7 (0.27) | 8           |
| 4 in. ASME CL 150   | 94 (3.7)           | 89 (3.5)        | 75 (2.95)   | 92 (3.62)                  | 157.2 (6.2) | 190.5 (7.5)   | 228.6 (9)    | 19.1 (0.79) | 22.4 (0.88) | 2 (0.08) | 8           |

| Size/Rating             | Dimensions mm (in) for S26FE smooth Form B2 and Form B1 |                 |              |               |            |            |            |            |           |          | N° of holes |
|-------------------------|---|-----------------|--------------|---------------|------------|------------|------------|------------|-----------|----------|-------------|
|                         | A (dia)   |                 |              |               |            |            |            |            |           |          |             |
|                         | extended diaphragm                                      | flush diaphragm |              | flushing ring |            |            |            |            |           |          |             |
|                         | std.  | low thick.      | internal dia | B (dia)       | C (dia)    | D (dia)    | E (dia)    | F (Note 2) | G         |          |             |
| DN 25 EN PN 16-40       | -   | 32 (1.26)       | -            | -             | 68 (2.68)  | 85 (3.34)  | 115 (4.53) | 14 (0.55)  | 16 (0.63) | 2 (0.08) | 4           |
| DN 25 EN PN 63-100      | -   | -               | 32 (1.26)    | -             | 68 (2.68)  | 100 (3.94) | 140 (5.51) | 18 (0.70)  | 22 (0.87) | 2 (0.08) | 4           |
| DN25ENPN16-40(recessed) | -   | -               | 52 (2.05)    | -             | 68 (2.68)  | 85 (3.34)  | 115 (4.53) | 14 (0.55)  | 20 (0.79) | 2 (0.08) | 4           |
| DN 40 EN PN 16-40       | -   | -               | 47.7 (1.88)  | -             | 88 (3.46)  | 110 (4.33) | 150 (5.90) | 18 (0.70)  | 15 (0.58) | 3 (0.12) | 4           |
| DN 40 EN PN 63-100      | -   | -               | 47.7 (1.88)  | -             | 88 (3.46)  | 125 (4.9)  | 170 (6.69) | 22 (0.86)  | 23 (0.90) | 3 (0.12) | 4           |
| DN 50 EN PN 16          | 48 (1.9)  | 60 (2.36)       | 58 (2.28)    | 62 (2.44)     | 102 (4.02) | 125 (4.92) | 165 (6.5)  | 18 (0.71)  | 15 (0.58) | 3 (0.12) | 4           |
| DN 50 EN PN 40          | 48 (1.9)  | 60 (2.36)       | 58 (2.28)    | 62 (2.44)     | 102 (4.02) | 125 (4.92) | 165 (6.5)  | 18 (0.71)  | 18 (0.67) | 3 (0.12) | 4           |
| DN 50 EN PN 63          | 48 (1.9)  | 60 (2.36)       | 58 (2.28)    | 62 (2.44)     | 102 (4.02) | 135 (5.31) | 180 (7.08) | 22 (0.86)  | 23 (0.9)  | 3 (0.12) | 4           |
| DN 50 EN PN 100         | 48 (1.9)  | 60 (2.36)       | 58 (2.28)    | 62 (2.44)     | 102 (4.02) | 145 (5.71) | 195 (7.67) | 26 (1.02)  | 27 (1.06) | 3 (0.12) | 4           |
| DN 80 EN PN 16          | 72 (2.83)   | 89 (3.5)        | 75 (2.95)    | 92 (3.62)     | 138 (5.43) | 160 (6.3)  | 200 (7.87) | 18 (0.71)  | 17 (0.67) | 3 (0.12) | 8           |
| DN 80 EN PN 40          | 72 (2.83)   | 89 (3.5)        | 75 (2.95)    | 92 (3.62)     | 138 (5.43) | 160 (6.3)  | 200 (7.87) | 18 (0.71)  | 21 (0.83) | 3 (0.12) | 8           |
| DN 80 EN PN 63          | 72 (2.83)   | 89 (3.5)        | 75 (2.95)    | 92 (3.62)     | 138 (5.43) | 170 (6.7)  | 215 (8.46) | 22 (0.86)  | 25 (0.98) | 3 (0.12) | 8           |
| DN 80 EN PN 100         | 72 (2.83)   | 89 (3.5)        | 75 (2.95)    | 92 (3.62)     | 138 (5.43) | 180 (7.08) | 230 (9.05) | 26 (1.02)  | 33 (1.3)  | 3 (0.12) | 8           |
| DN 100 EN PN 16         | 94 (3.7)  | 89 (3.5)        | 75 (2.95)    | 92 (3.62)     | 158 (6.22) | 180 (7.08) | 220 (8.66) | 18 (0.71)  | 17 (0.67) | 3 (0.12) | 8           |

| Size/Rating     | Dimensions mm (in) for S26FE Form E |               |            |            |            |           |             |            |   | N° of holes |
|-----------------|-------------------------------------|---------------|------------|------------|------------|-----------|-------------|------------|---|-------------|
|                 | diaphragm A (dia)                   |               | B (dia)    | C (dia)    | D (dia)    | E (dia)   | F (Note 2)  | G          |   |             |
|                 | std. thickness                      | low thickness |            |            |            |           |             |            |   |             |
| DN 50 EN PN 16  | 60 (2.36)                           | 58 (2.28)     | 87 (3.42)  | 125 (4.92) | 165 (6.5)  | 18 (0.71) | 13.5 (0.53) | 4.5 (0.18) | 4 |             |
| DN 50 EN PN 40  | 60 (2.36)                           | 58 (2.28)     | 87 (3.42)  | 125 (4.92) | 165 (6.5)  | 18 (0.71) | 15.5 (0.61) | 4.5 (0.18) | 4 |             |
| DN 50 EN PN 63  | 60 (2.36)                           | 58 (2.28)     | 87 (3.42)  | 135 (5.31) | 180 (7.08) | 22 (0.86) | 21.5 (0.85) | 4.5 (0.18) | 4 |             |
| DN 50 EN PN 100 | 60 (2.36)                           | 58 (2.28)     | 87 (3.42)  | 145 (5.71) | 195 (7.67) | 26 (1.02) | 25.5 (1)    | 4.5 (0.18) | 4 |             |
| DN 80 EN PN 16  | 89 (3.5)                            | 75 (2.95)     | 120 (4.72) | 160 (6.3)  | 200 (7.87) | 18 (0.71) | 15.5 (0.61) | 4.5 (0.18) | 8 |             |
| DN 80 EN PN 40  | 89 (3.5)                            | 75 (2.95)     | 120 (4.72) | 160 (6.3)  | 200 (7.87) | 18 (0.71) | 19.5 (0.77) | 4.5 (0.18) | 8 |             |
| DN 80 EN PN 63  | 89 (3.5)                            | 75 (2.95)     | 120 (4.72) | 170 (6.7)  | 215 (8.46) | 22 (0.86) | 23.5 (0.92) | 4.5 (0.18) | 8 |             |
| DN 80 EN PN 100 | 89 (3.5)                            | 75 (2.95)     | 120 (4.72) | 180 (7.08) | 230 (9.05) | 26 (1.02) | 31.5 (1.24) | 4.5 (0.18) | 8 |             |
| DN 100 EN PN 16 | 89 (3.5)                            | 75 (2.95)     | 149 (5.87) | 180 (7.08) | 220 (8.66) | 18 (0.71) | 15 (0.59)   | 5 (0.20)   | 8 |             |

| Size/Rating     | Dimensions mm (in) for S26FE Form D |               |            |            |            |           |            |            |            |            | N° of holes |
|-----------------|-------------------------------------|---------------|------------|------------|------------|-----------|------------|------------|------------|------------|-------------|
|                 | diaphragm A (dia)                   |               | B (dia)    | C (dia)    | D (dia)    | E (dia)   | F (Note 2) | H (dia)    | I (dia)    | L          |             |
|                 | std. thickness                      | low thickness |            |            |            |           |            |            |            |            |             |
| DN 50 EN PN 16  | 60 (2.36)                           | 58 (2.28)     | 102 (4.02) | 125 (4.92) | 165 (6.5)  | 18 (0.71) | 15 (0.59)  | 72 (2.83)  | 88 (3.46)  | 4 (0.16)   | 4           |
| DN 50 EN PN 40  | 60 (2.36)                           | 58 (2.28)     | 102 (4.02) | 125 (4.92) | 165 (6.5)  | 18 (0.71) | 18 (0.71)  | 72 (2.83)  | 88 (3.46)  | 4 (0.16)   | 4           |
| DN 50 EN PN 63  | 60 (2.36)                           | 58 (2.28)     | 102 (4.02) | 135 (5.31) | 180 (7.08) | 22 (0.86) | 23 (0.91)  | 72 (2.83)  | 88 (3.46)  | 4 (0.16)   | 4           |
| DN 50 EN PN 100 | 60 (2.36)                           | 58 (2.28)     | 102 (4.02) | 145 (5.71) | 195 (7.67) | 26 (1.02) | 27 (1.06)  | 72 (2.83)  | 88 (3.46)  | 4 (0.16)   | 4           |
| DN 80 EN PN 16  | 89 (3.5)                            | 75 (2.95)     | 138 (5.43) | 160 (6.3)  | 200 (7.87) | 18 (0.71) | 17 (0.67)  | 105 (4.13) | 121 (4.76) | 4 (0.16)   | 8           |
| DN 80 EN PN 40  | 89 (3.5)                            | 75 (2.95)     | 138 (5.43) | 160 (6.3)  | 200 (7.87) | 18 (0.71) | 21 (0.83)  | 105 (4.13) | 121 (4.76) | 4 (0.16)   | 8           |
| DN 80 EN PN 63  | 89 (3.5)                            | 75 (2.95)     | 138 (5.43) | 170 (6.7)  | 215 (8.46) | 22 (0.86) | 25 (0.92)  | 105 (4.13) | 121 (4.76) | 4 (0.16)   | 8           |
| DN 80 EN PN 100 | 89 (3.5)                            | 75 (2.95)     | 138 (5.43) | 180 (7.08) | 230 (9.05) | 26 (1.02) | 33 (1.3)   | 105 (4.13) | 121 (4.76) | 4 (0.16)   | 8           |
| DN 100 EN PN 16 | 89 (3.5)                            | 75 (2.95)     | 158 (6.22) | 180 (7.08) | 220 (8.66) | 18 (0.71) | 17 (0.67)  | 128 (5.04) | 149 (5.91) | 4.5 (0.18) | 8           |

Note 1 - Flange thickness tolerance is +3.0 / -0.0 mm (+0.12 / 0.0 in.).

Note 2 - Flange thickness tolerance is +1.0 / -1.3 mm (+0.04 / 0.05 in.) up to 18 mm or ±1.5 mm (±0.06 in.) from 18 to 50 mm from 18 to 50 mm.

For any other detailed information regarding S26RR seal such as pressure limits, vacuum service recommendations, process temperature limits, temperature effects and configuration, please refer to product datasheet.

### Off-line Threaded Connection Seal (S26TT)

The off-line threaded remote seal connects directly to a process pipe via the NPT connection in the lower housing. Connections for 1/4, 1/2, 3/4, 1, and 1-1/2 in. process piping are available. In addition to the process connection, mechanical support for the weight of the seal may be required, especially for the 1/4 and 1/2-inch pipe sizes.

These elements are available with a flushing connection in the lower housing. The connection provides a 1/4 in. NPT port into the cavity around the seal diaphragm to permit flushing to remove trapped solids, when necessary. The flushing connection also provides a means of checking calibration without disconnecting the element. A gate or ball valve installed in the process line near the seal element connection allows the process to be isolated and calibration pressure can then be applied via the flushing connection. Use of a gate or ball type valve avoids restricting the process line during normal operation, not a gasket.

Connect the seal element to the process pipe at the NPT connection in the end of the lower housing.

If the element has a flushing connection, connect a flushing line with appropriate valving to the 1/4 in. NPT connection in the side of the lower housing.

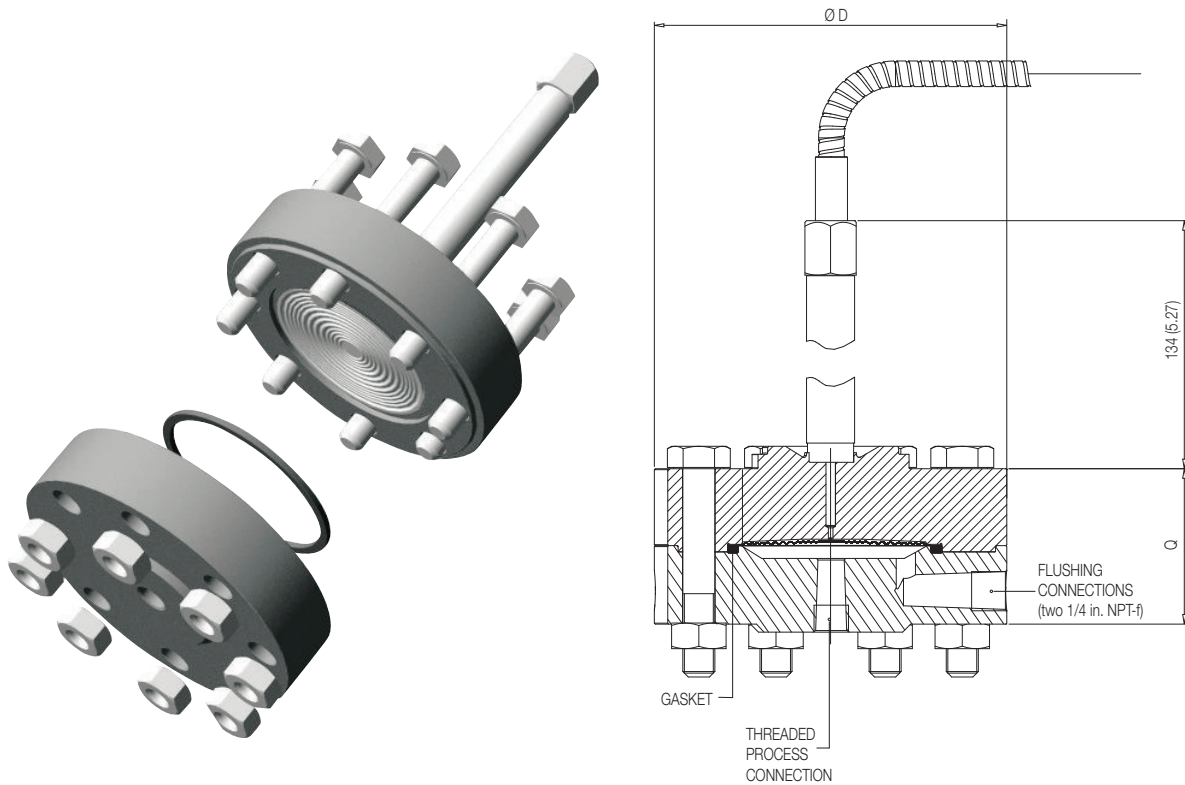

Figure 7: Off-line threaded connection diaphragm seal

| Size (thread) | Dimensions mm (in) for S26T |            |
|---------------|-----------------------------|------------|
|               | D (dia)                     | Q          |
| 1/4 in. NPT   | 109.2 (4.3)                 | 53.3 (2.1) |
| 1/2 in. NPT   | 109.2 (4.3)                 | 53.3 (2.1) |
| 3/4 in. NPT   | 109.2 (4.3)                 | 63.5 (2.5) |
| 1 in. NPT     | 109.2 (4.3)                 | 63.5 (2.5) |
| 1 1/2 in. NPT | 109.2 (4.3)                 | 63.5 (2.5) |

S26TT can be supplied with different kinds of bolts: stainless steel AISI 316, carbon steel or alloy steel (NACE compliant)

For any other detailed information regarding S26TT seals such as pressure limits, vacuum service recommendations, process temperature limits, temperature effects and configuration, please refer to product datasheet.



**Off-Line Flanged Connection Remote Seal (S26MA, S26ME)**

Available with ASME (S26MA) and EN (S26ME) flanged process connection, the Off-line model matches small process connections. Recommended for clean process fluid measurements.

These elements are available with a flushing connection in the lower housing, selectable on request.

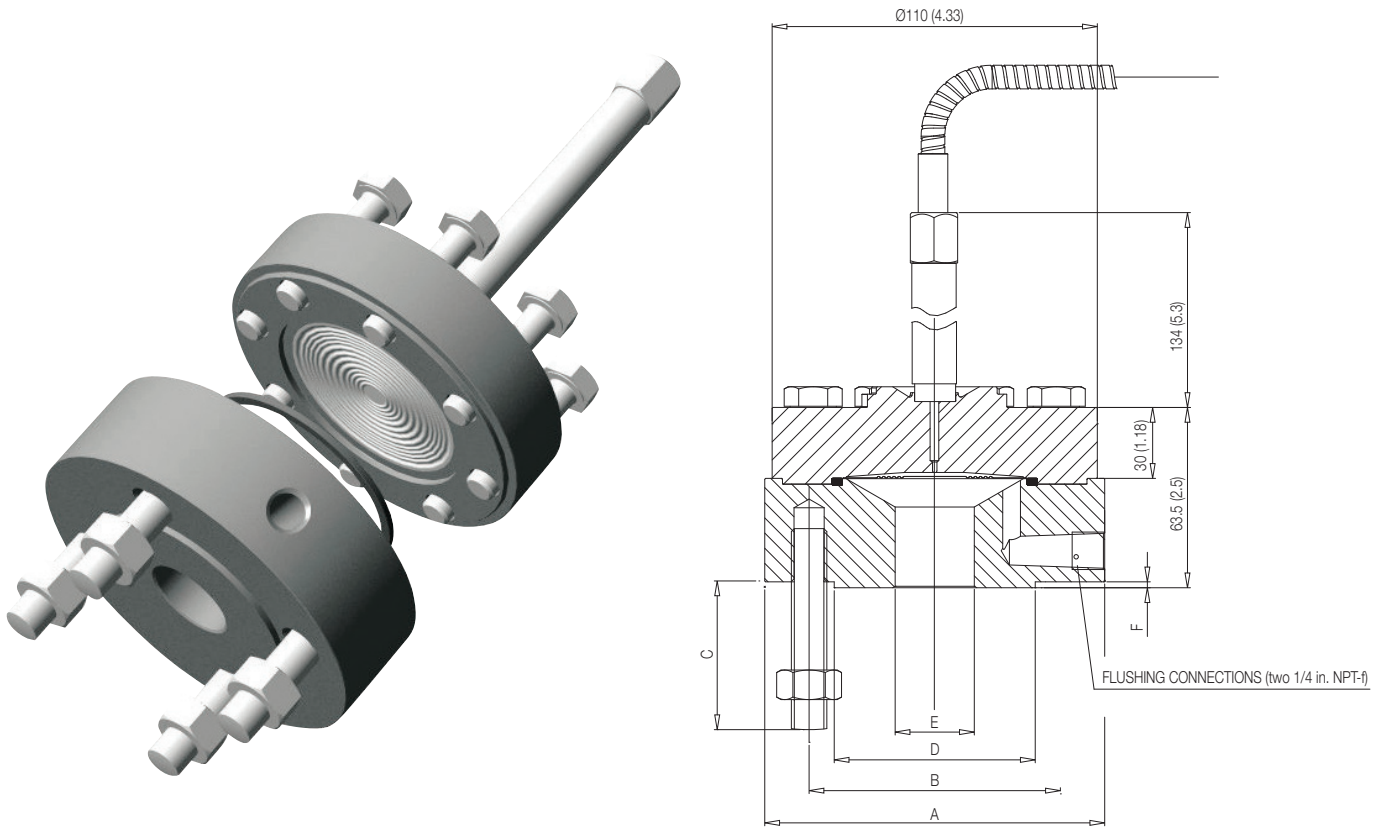

Figure 8: Off-line flanged diaphragm seal

| Size/Rating           | Dimensions mm (in) for S26MA and S26ME |             |             |                |             |             |            |
|-----------------------|--|-------------|-------------|----------------|-------------|-------------|------------|
|                       | A (dia)                                | B (dia)     | C (4 studs) |                | D (dia)     | E (dia)     | F          |
|                       |  |             | Length      | Thread         |             |             |            |
| 1/2 in. ASME CL 150   | 110 (4.33)                             | 60.5 (2.38) | 39 (1.53)   | 1/2in – 13 UNC | 35.1 (1.38) | 15.8 (0.62) | 1.6 (0.06) |
| 1/2 in. ASME CL 300   | 110 (4.33)                             | 66.5 (2.62) | 39 (1.53)   | 1/2in – 13 UNC | 35.1 (1.38) | 15.8 (0.62) | 1.6 (0.06) |
| 1 in. ASME CL 150     | 110 (4.33)                             | 79.4 (3.12) | 39 (1.53)   | 1/2in – 13 UNC | 50.8 (2)    | 26.7 (1.05) | 1.6 (0.06) |
| 1 in. ASME CL 300     | 124 (4.88)                             | 88.9 (3.5)  | 51 (2)      | 5/8in – 11 UNC | 50.8 (2)    | 26.7 (1.05) | 1.6 (0.06) |
| 1 1/2 in. ASME CL 150 | 127 (5)                                | 98.4 (3.87) | 39 (1.53)   | 1/2in – 13 UNC | 73 (2.87)   | 41 (1.61)   | 1.6 (0.06) |
| 1 1/2 in. ASME CL 300 | 155 (6.1)                              | 114.3 (4.5) | 57 (2.24)   | 3/4in – 10 UNC | 73 (2.87)   | 41 (1.61)   | 1.6 (0.06) |
| DN 25 PN 16-40        | 115 (4.52)                             | 85 (3.34)   | 42 (1.65)   | M12            | 68 (2.67)   | 28.5 (1.12) | 2 (0.08)   |
| DN 40 PN 16-40        | 150 (5.9)                              | 110 (4.33)  | 48 (1.89)   | M16            | 88 (3.46)   | 43.1 (1.69) | 3 (0.12)   |

**IMPORTANT**

This diaphragm seal features two flushing connections.

For any other detailed information regarding S26Mx seals such as pressure limits, vacuum service recommendations, process temperature limits, bolts, gasket seat finishing, temperature effects and configuration, please refer to product datasheet.



**Remote Seal for Urea Service (S26PN)**

This specialized remote seal is manufactured from materials which match the aggressively corrosive conditions when Urea is present in the process.

The urea grade wetted materials ensure stable performances even in high temperature / high vacuum conditions.

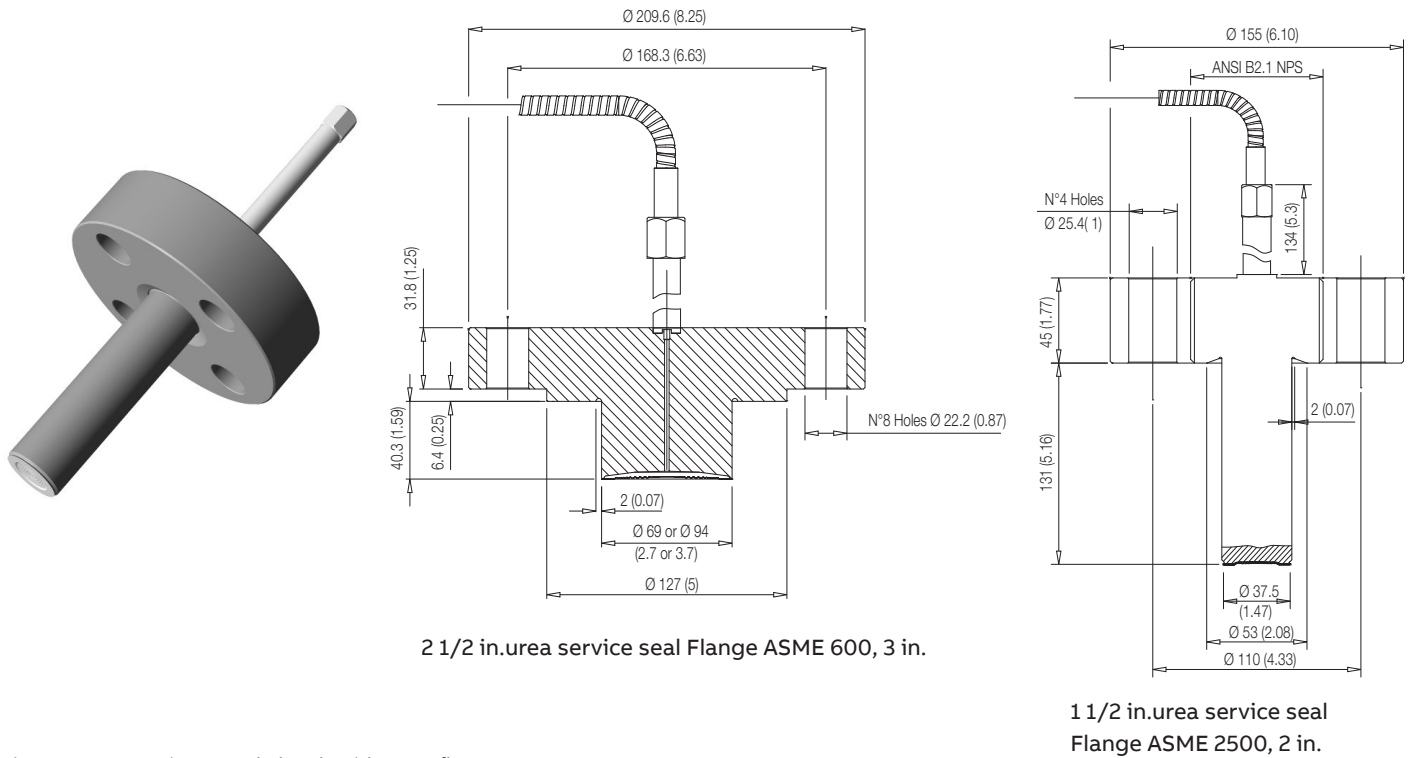

Figure 9: Urea service extended seals with ASME flange

For any other detailed information regarding S26PN seal such as pressure limits, vacuum service recommendations, process temperature limits, bolts, temperature effects and configuration, please refer to product datasheet.

**Button Type remote seal (S26BN)**

This remote seal is designed to connect to a process via the NPT threaded connection or to match pipe fitting with an interface suitable for the provided mating flange. The button seals, thanks to their accurate design, are projected to carry out accurate measurements with medium/high calibrated span (2 MPa - 20 bar - 290 psi approx or greater).

The button type remote seal is to be used only for gauge pressure.

This type of connection is especially suitable for plastic and resins production processes.

For any other detailed information regarding S26BN seals such as pressure limits, vacuum service recommendations, process temperature limits, temperature effects and configuration, please refer to product datasheet.

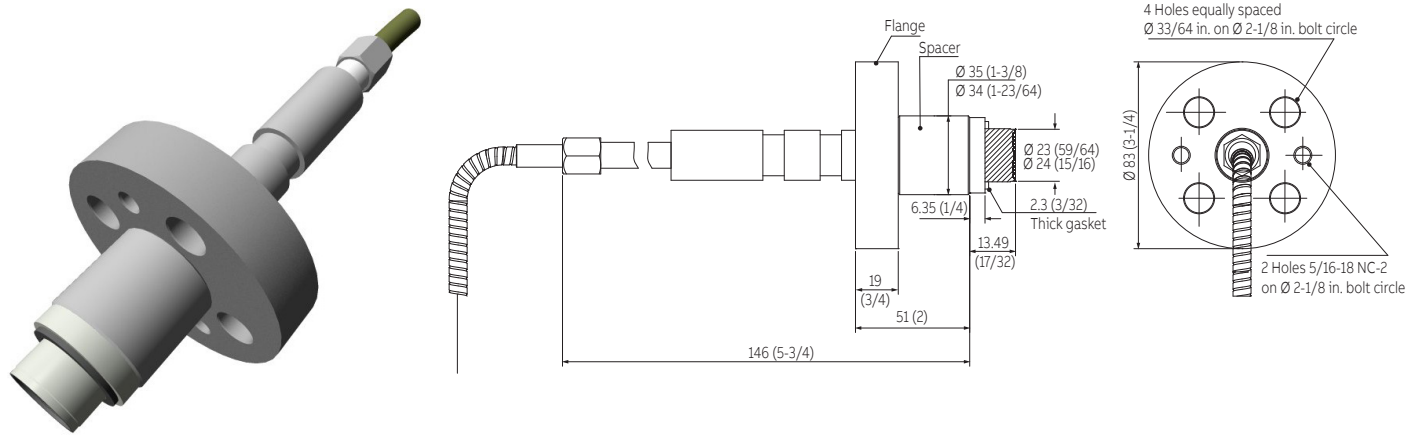

Figure 10: 3-1/4 in. flange extended – type 91

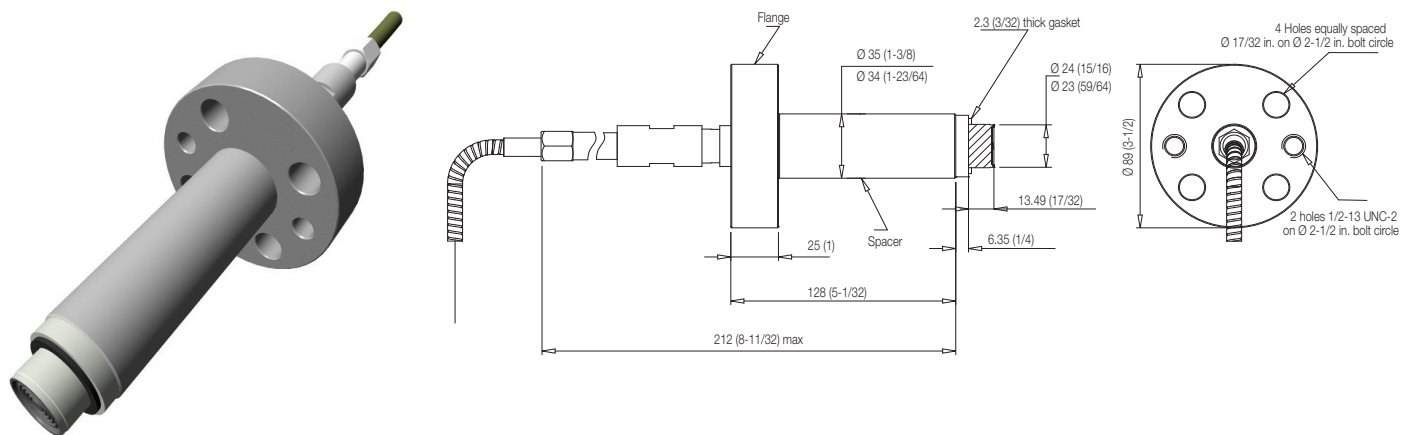

Figure 11: 3-1/4 in. flange extended – type 91 modified

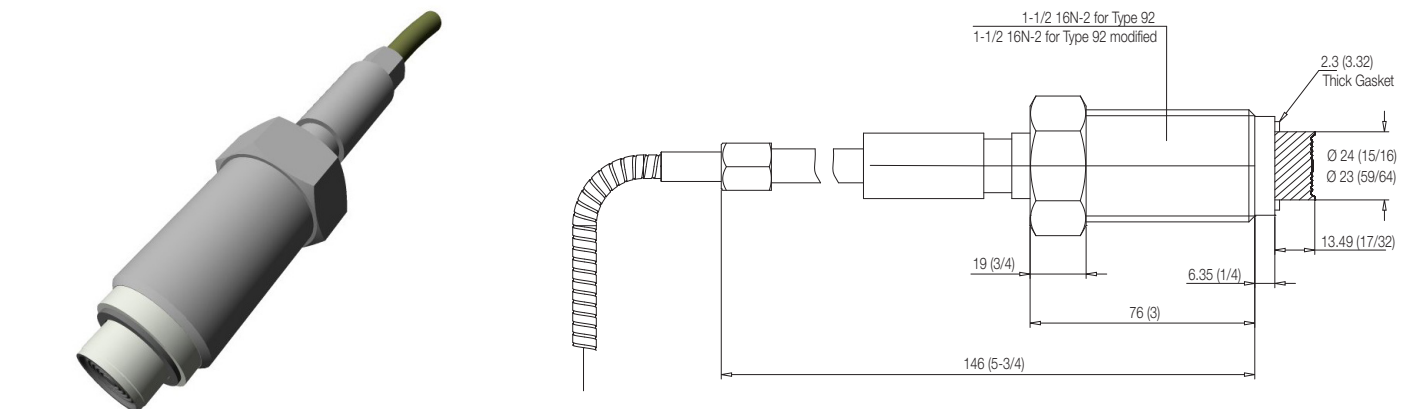

Figure 12: 1-1/2 in. threaded union type 92 or 92 modified

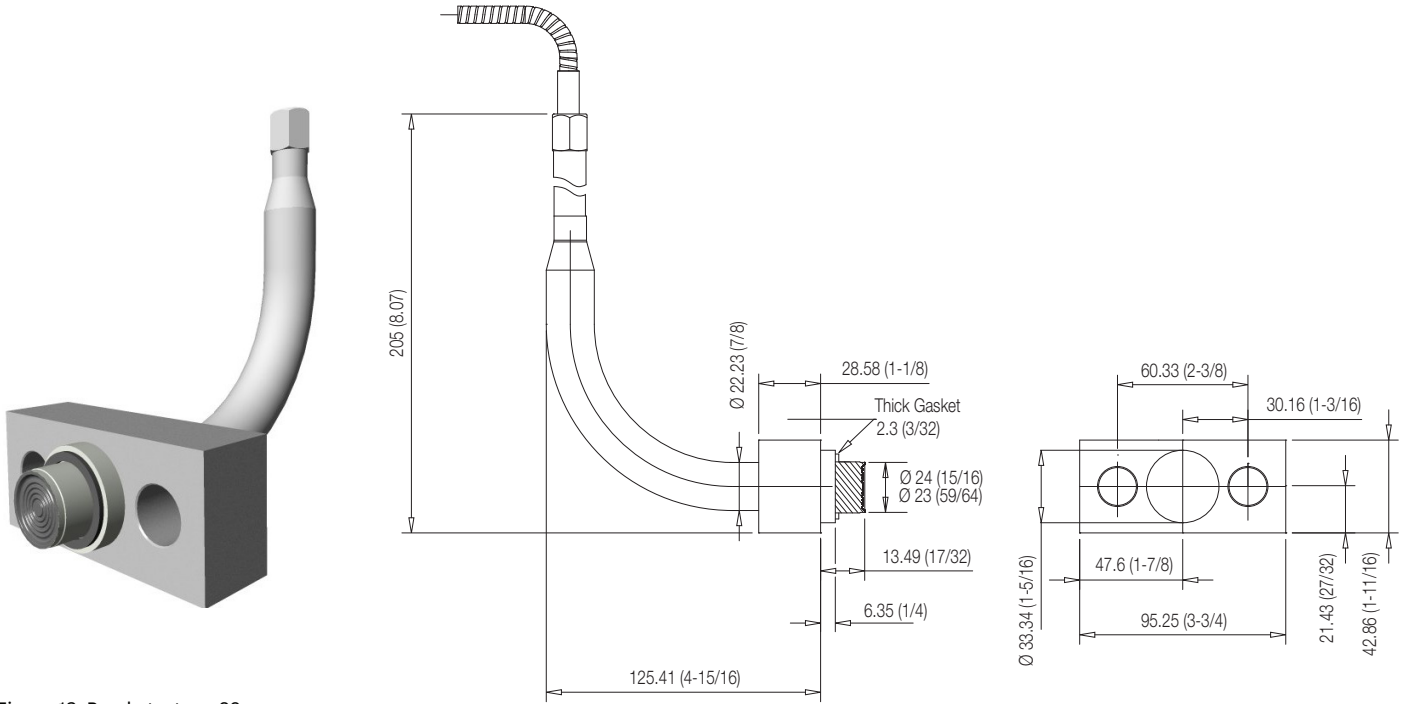

Figure 13: Bracket – type 89

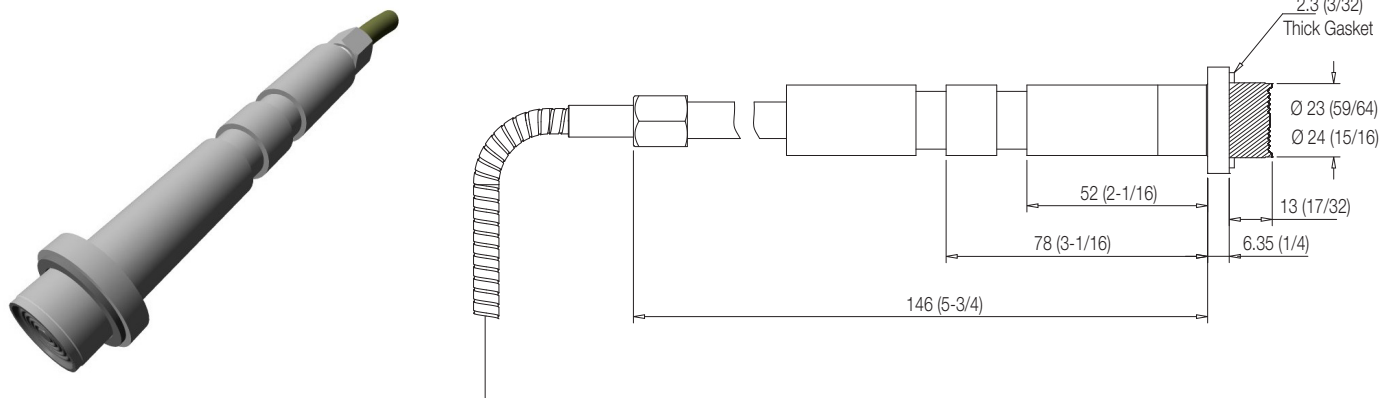

Figure 14: Universal – type 90

### Food and Sanitary seal (S26SS)

Sanitary diaphragm seals have been specifically developed for food, sanitary, chemical and pharmaceutical applications, complying with the stringent 3-A requirements.

Available with different process fittings (Triclamp, Cherry Burrell, Union Nut and Sanitary), this model highlights ABB's commitment to satisfy users needs approaching even the most demanding processes successfully.

#### Cherry Burrell Aseptic

The sanitary aseptic remote seal is designed to connect to a 4in sanitary fitting: either an aseptic tank spud or a 4in Cherry Burrell aseptic ferrule. The tank spud, gaskets and V-band clamp are available option with the seal element.

## NOTICE

The tank spud or ferrule required for connection of this seal element must be welded to the process vessel prior to connecting the element, following recommended welding and pressure testing procedure. Weld the Cherry Burrell ferrule to the process vessel in accordance with manufacturers' recommendations.

Connect the sanitary aseptic seal to the tank spud or ferrule as follows:

1. Remove protective covering from seal.
2. Install two O-rings on the periphery of the seal and an O-ring under each steam connection fitting.
3. Insert the seal into the tank spud or ferrule and place the steam connection cap against the back of the element.
4. Position the clamp ring as shown and tighten to seal the O-rings against the spud.
5. Connect the inlet and outlet steam lines to the  $\frac{1}{8}$ " NPT steam connections in the cap. Steam temperature must not exceed 149°C (300°F); pressure must not exceed 358.5 KPa (52psi).

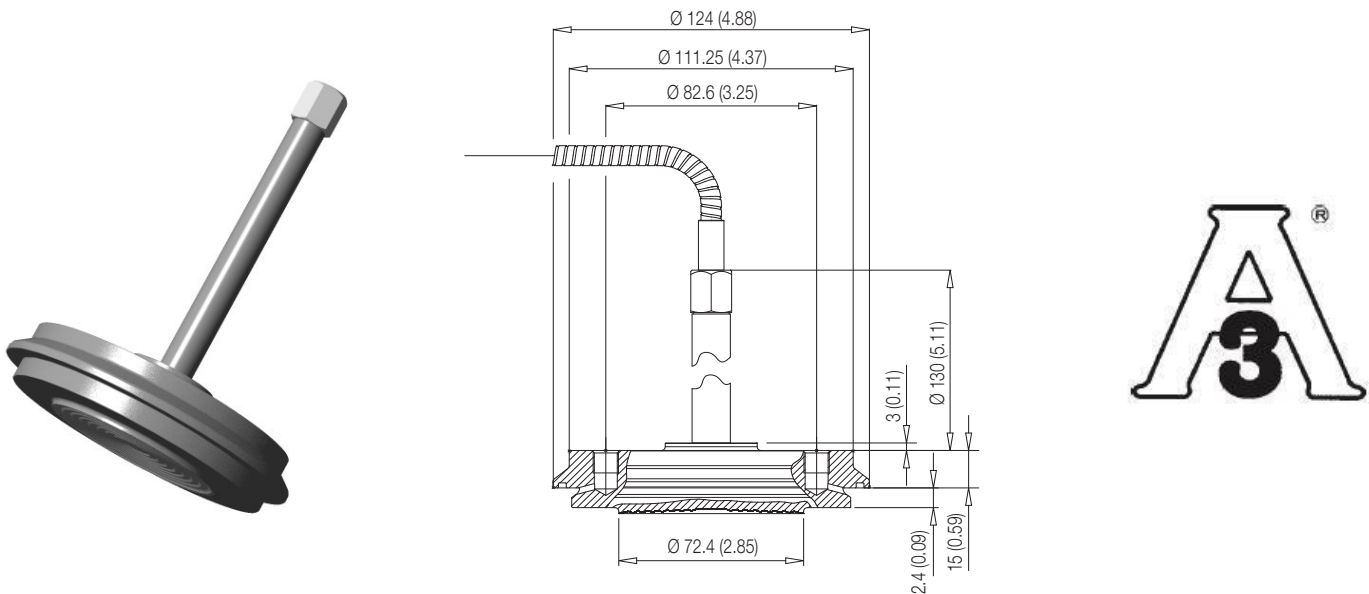

Figure 15: 4 in. Cherry Burrell Aseptic

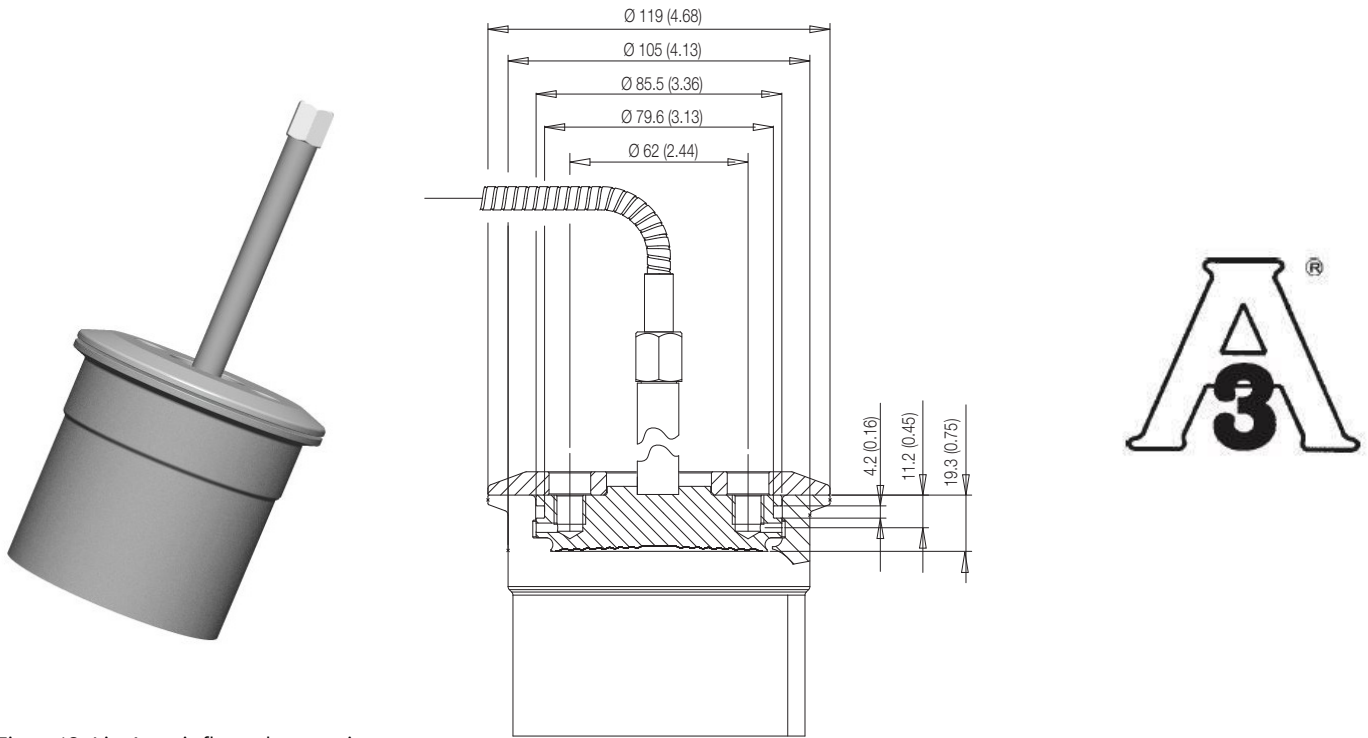

Figure 16: 4 in. Aseptic flanged connection

**Sanitary Seal with flush diaphragm**

The sanitary remote seal with flush diaphragm is designed to connect to a 4-inch sanitary tank spud. The tank spud and process O-ring, made of Buna or Viton, are available with the seal.

Connect the seal as follows:

1. Remove protective covering from seal and install the process O-ring.
2. Insert the seal into the tank spud.
3. Position the clamp ring as shown and tighten to seal the O-ring against the spud.

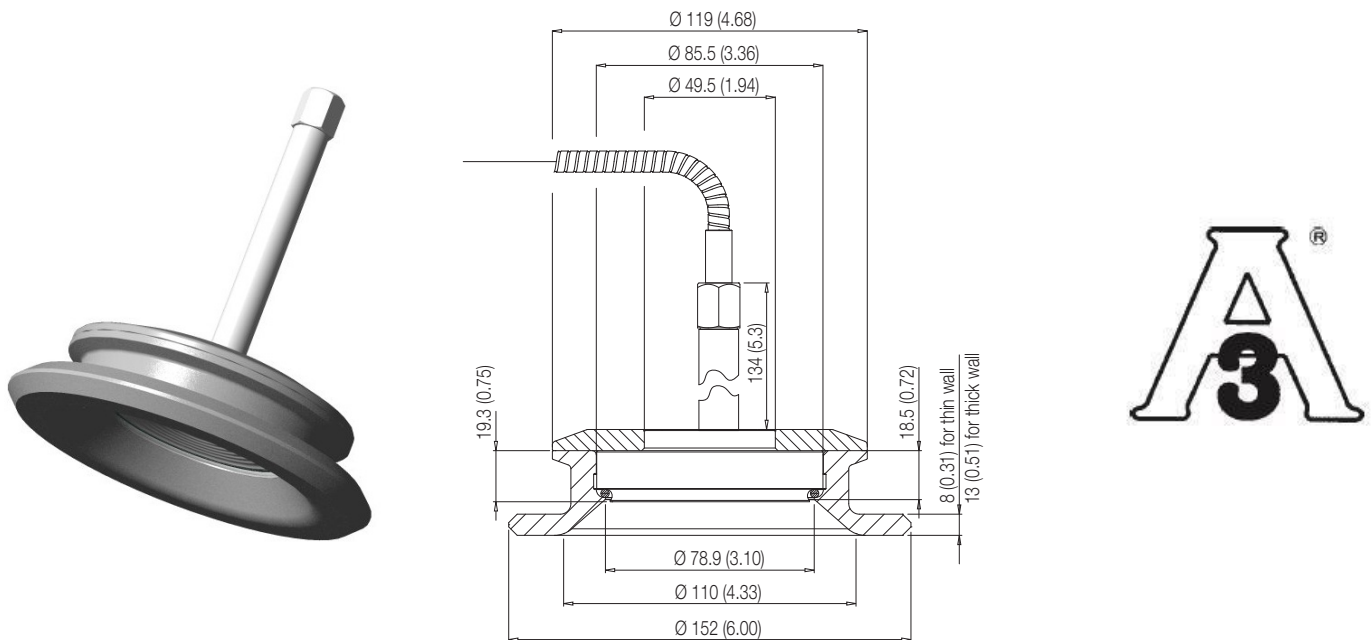

Figure 17: Sanitary seal with flush diaphragm

**Sanitary seal with extended diaphragm**

The sanitary remote seal with extended diaphragm is designed to connect to a 4-inch sanitary tank spud with an extended neck (2, 4 or 6 inches). The tank spud, an Ethylene Propylene process O-ring and V-Band clamp ring are available with the seal.

Connect the seal as follows:

1. Weld the tank spud into the process vessel. Be sure to orient the spud so that the drain hole is at the lowest point.
2. Remove protective covering from seal and install the O-ring.
3. Insert the seal into the tank spud.
4. Position the clamp ring over the joint between the seal and spud and tighten the clamp.

**NOTICE**

The tank spud required for connection of this seal element must be welded to the process vessel prior to connecting the seal, following a recommended welding and pressure testing procedure.

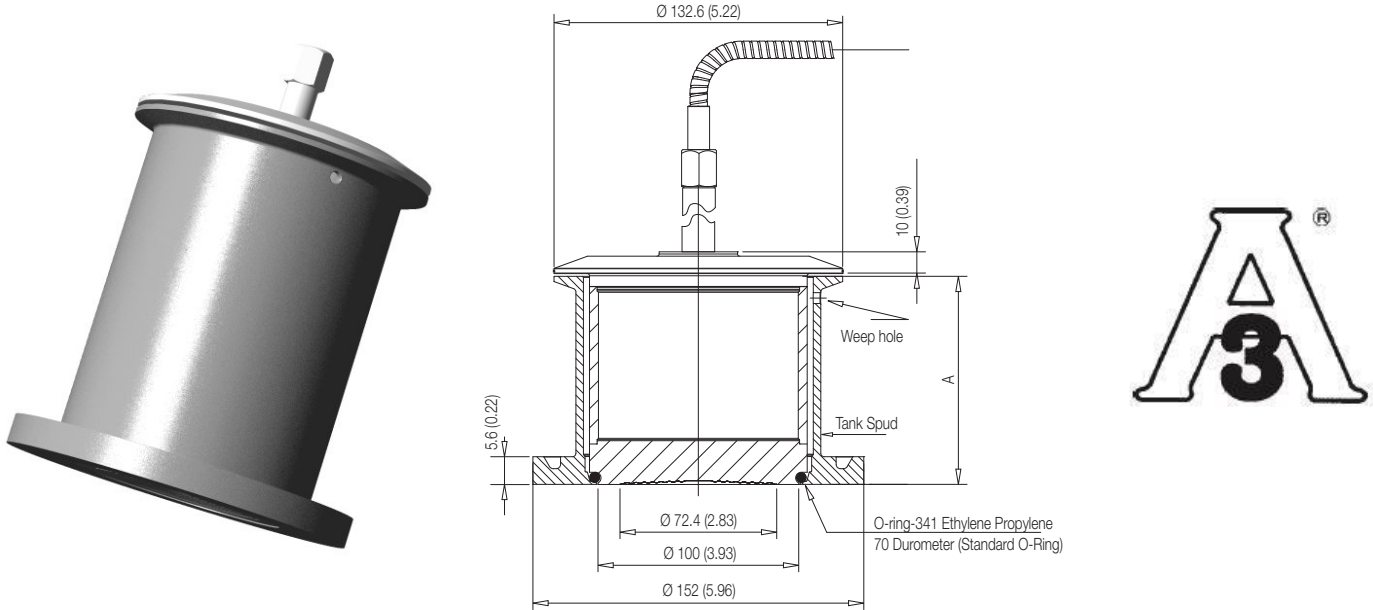

Figure 18: Sanitary seal with extended diaphragm

**Union Nut and Triclamp remote seal**

The Union Nut and Triclamp seals are designed for connection by Union Nut according to DIN 11851 - F50 or F80 and 2in, 3in, 4in Triclamp sanitary fittings. A variety of gaskets and clamp rings for the seals are available.

**NOTICE**

This kind of diaphragm seal does not comply with the stringent 3A standard requirements. Therefore, it is not covered by the relevant certification.

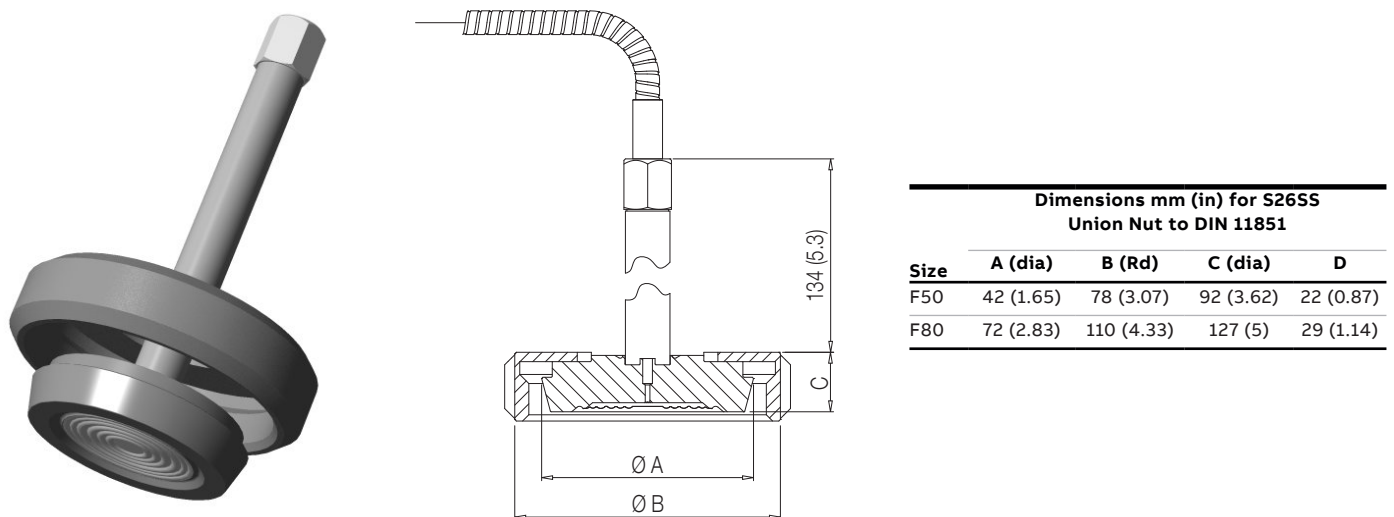

Figure 19: Union Nut sanitary seal

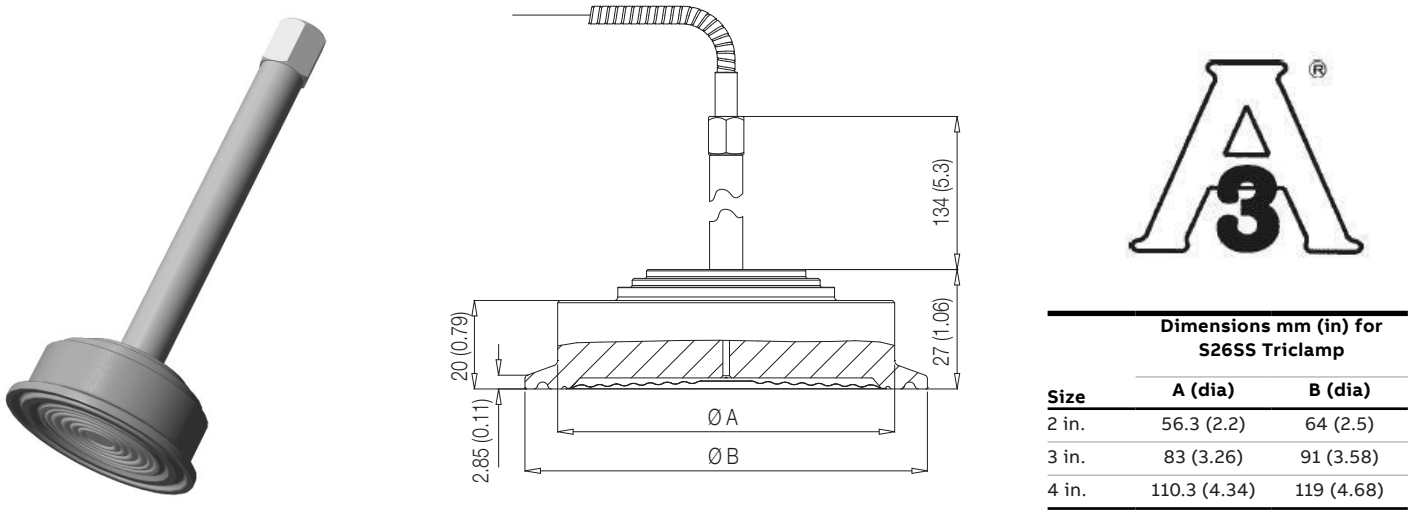

Figure 20: Triclamp sanitary seal

**Cherry Burrell seal**

The Cherry Burrell seals are designed for connection to 2in, 3in or 4in Cherry Burrell I-Line sanitary fittings. A 4in. V-band clamp is optionally available for the 4in. variant.

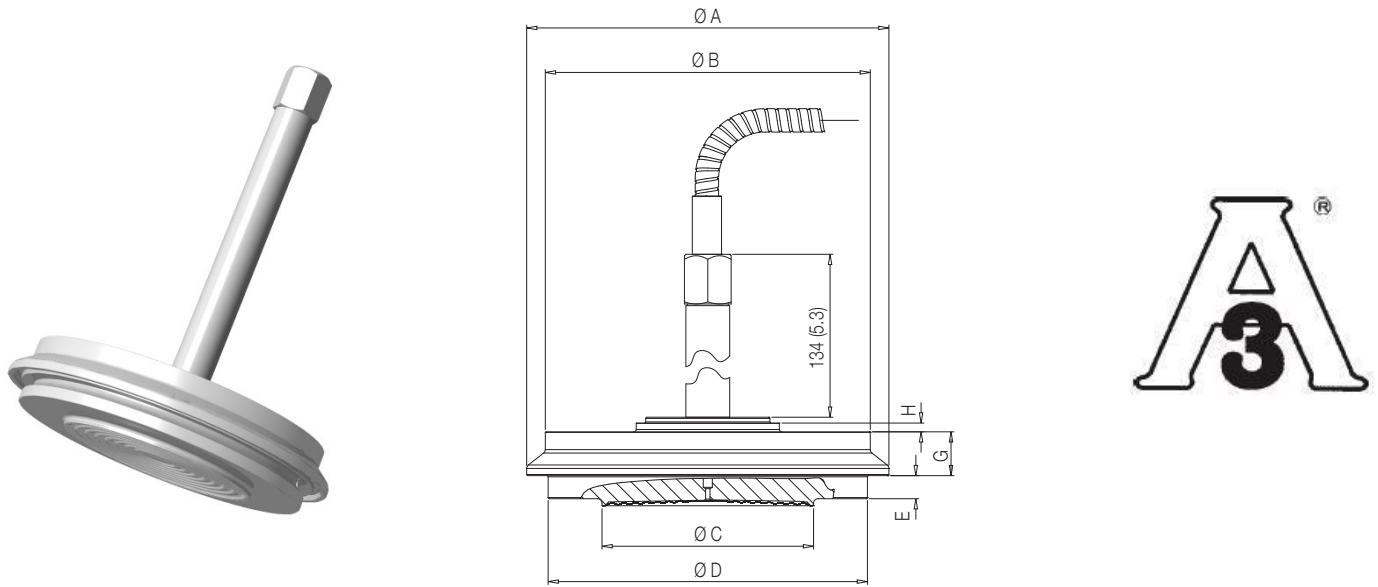

Figure 21: Cherry Burrell sanitary seal

| Size  | A (dia)     | B (dia)       | C (dia)      | D (dia)     | E          | F          | G           | H        |
|-------|-------------|---------------|--------------|-------------|------------|------------|-------------|----------|
| 2 in. | 67 (2.64)   | 56 (2.2)      | 42 (1.65)    | 57 (2.24)   | 3.2 (0.13) | 6.5 (0.26) | 12.5 (0.49) | 3 (0.12) |
| 3 in. | 98.4 (3.87) | 81 (3.19)     | 72.42 (2.85) | 83.8 (3.3)  | 2.4 (0.09) | 7.9 (0.31) | 15 (0.59)   | 3 (0.12) |
| 4 in. | 124 (4.88)  | 111.25 (4.38) | 72.42 (2.85) | 109.3 (4.3) | 2.4 (0.09) | 7.9 (0.31) | 15 (0.59)   | 3 (0.12) |

### Beverage bolted seal

This seal has been designed to be suited for specific applications in beverage processes. The sanitary bolted seal is available only for gauge and absolute transmitters with direct-mount seal construction. Spud process fitting is available on request.

## NOTICE

This kind of diaphragm seal does not comply with the stringent 3A standard requirements. Therefore, it is not covered by the relevant certification.

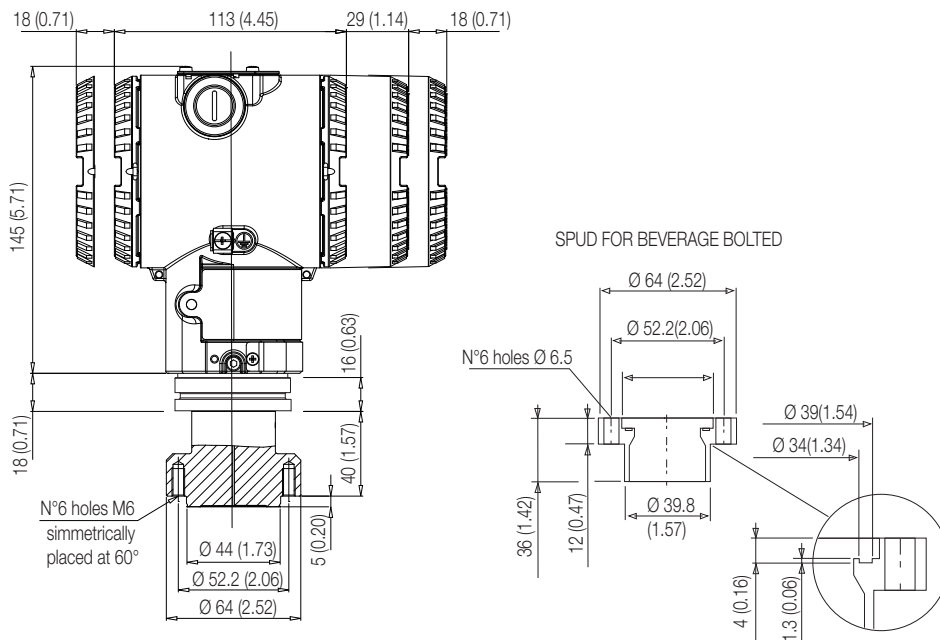

Figure 22: Beverage bolted seal on 266HRH and 266NRH

### 3-A requirements

All sanitary S26SS remote diaphragm seals and other associated direct mount sanitary diaphragm seals must be mounted in such a way as to allow for drainage of all process fluids. Tank spud fittings must be mounted with the leak detection hole located at the bottom for proper drainage by gravity. Sanitary applications must be performed so that all welding surface are smooth with roughness lower than 0,8  $\mu\text{m}$ , in order to prevent dirt from lodging inside surface irregularities.

3-A seals are equipped with a specific label (see below) indicating the temperature range and gasket characteristics.

#### 3-A Sanitary Seal Gasket Temperature Range

EPDM:3-A 18-03 Class II, -40 to 121°C (-40 to 250°F)

Figure 23: Adhesive label for 3-A certified S26SS seals

For any other detailed information regarding S26SS seals such as pressure limits, vacuum service recommendations, process temperature limits, temperature effects and configuration, please refer to product datasheet section of this document.



**Pulp and Paper diaphragm seals (S26KN)**

Models 266HRH, 266NRH, 266GRH and 266ARH integrate a direct mount seal on the positive side, having the negative side reference at atmospheric or vacuum pressure, respectively for gauge or absolute measurements.

The integral seal is available in 1in and 1-1/2 in diaphragm sizes specifically designed for pulp & paper industry applications, providing a flush diaphragm to the process; this solution ensures the measure reliability avoiding all problems of crystallization/ polymerization, typical of pulps having viscosity as in the paper mill.

**IMPORTANT**

Use of proper procedures and fixtures avoid the risks of personal injury or plant damage. The recommended minimum radius of curvature of the tank is 0.91 m (3 feet). Allowed fill fluids are Silicone Oil DC200TM and mineral oil Marcol 82TM.

**1 in. and 1-1/2 in. size with 1 in. and 1-1/2 in. NPT threaded connection**

This particular process connection can withstand a maximum working pressure of 345bar (5000psi). The wetted parts are available in AISI 316L, Hastelloy C276™ and Diaflex (anti-abrasion diaphragm treatment).

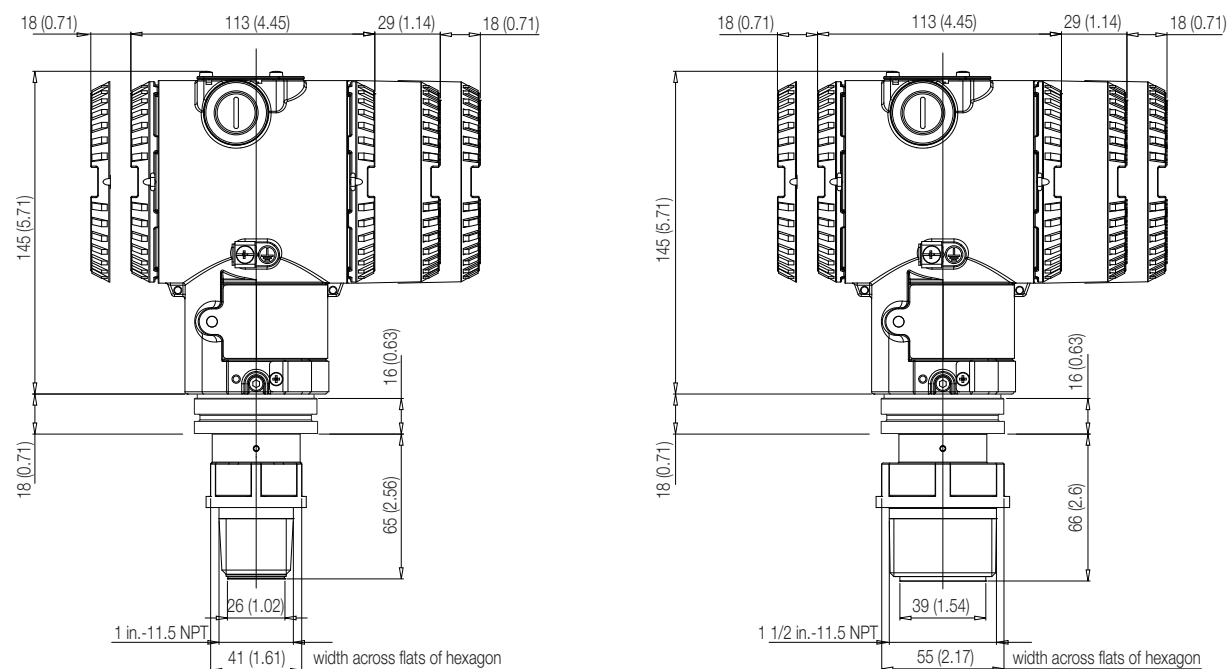

Figure 24: S26KN with NPT threaded connectionI

**1 in. and 1-1/2 in. size with G 1 in. A and G 1-1/2 in. A threaded connection**

This particular process connection can withstand a maximum working pressure of 600bar (8700psi). The wetted parts are available in AISI 316L, Hastelloy C276™ and Diaflex (anti-abrasion diaphragm treatment).

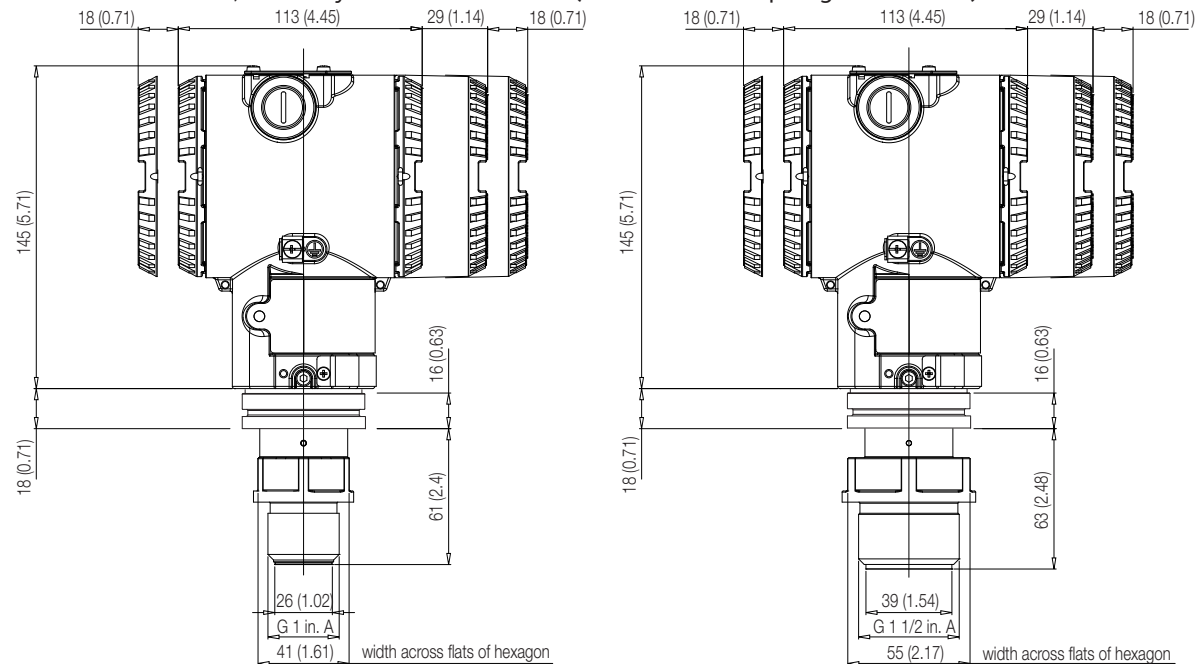

Figure 25: S26KN with GAS threaded connection

**1 in and 1-1/2 in size to spud with 1 or 2 screw(s) fixing**

Consider that this kind of pulp and paper sealing with gasket seal can withstand a maximum working pressure of:

- 30bar (435psi) in case of 1 screw fixing
- 50bar (725psi) in case of 2 screws fixing

The wetted parts are available in AISI 316L, Hastelloy C276™ and Diaflex (anti-abrasion diaphragm treatment).

While installing, please use the appropriate Viton™ gasket.

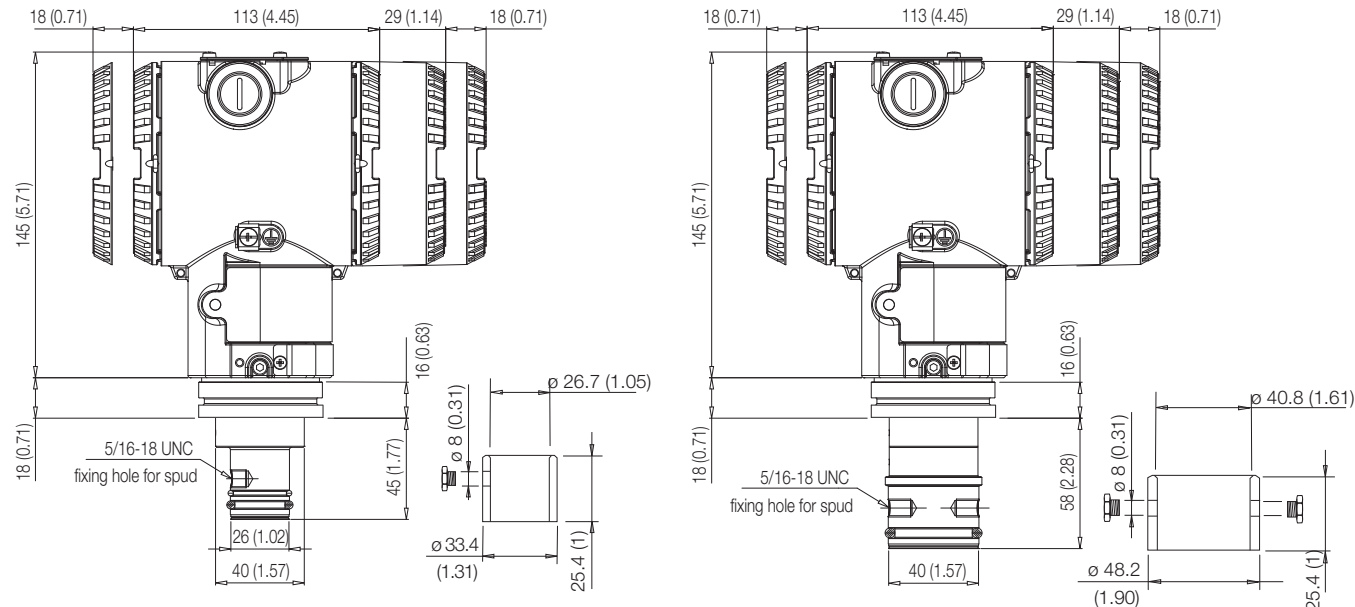

Figure 26: S26KN with spuds and fixing screws

**1 in. G with ball valve connection**

This special connection allows easy instrument mounting on ball valves which are easy to install and repair. They offer user the opportunity of avoiding complete plant shutdown. This process connection can withstand a maximum working pressure of 40bar (580psi). The wetted parts are available only in Hastelloy C276™.

**1-1/2 in. sealing connection to threaded spud (M44 x1.5)**

Consider that this particular process connection can withstand a maximum working pressure of 50bar (725psi). While installing, please use the appropriate PTFE gasket. The wetted parts are available in AISI 316L, Hastelloy C276™ and Diaflex (anti-abrasion diaphragm treatment).

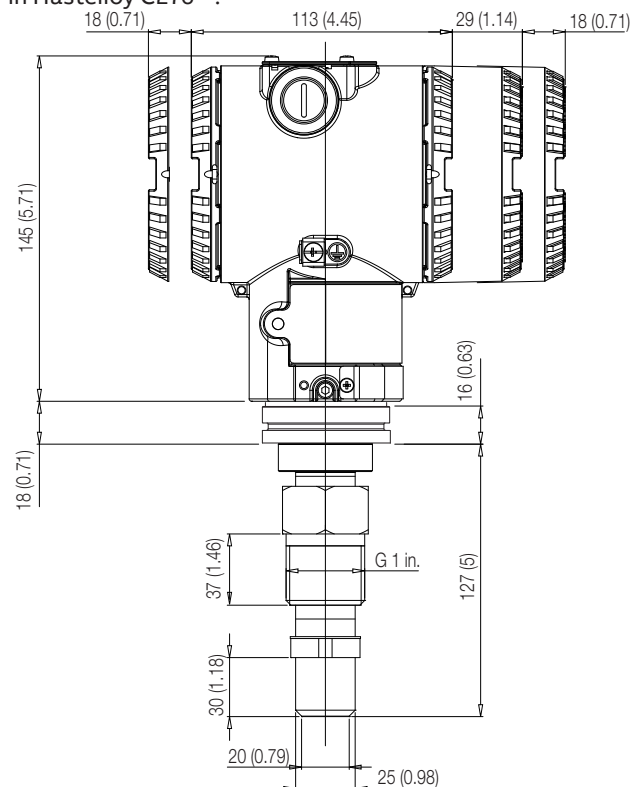

Figure 27: S26KN with ball valve connection

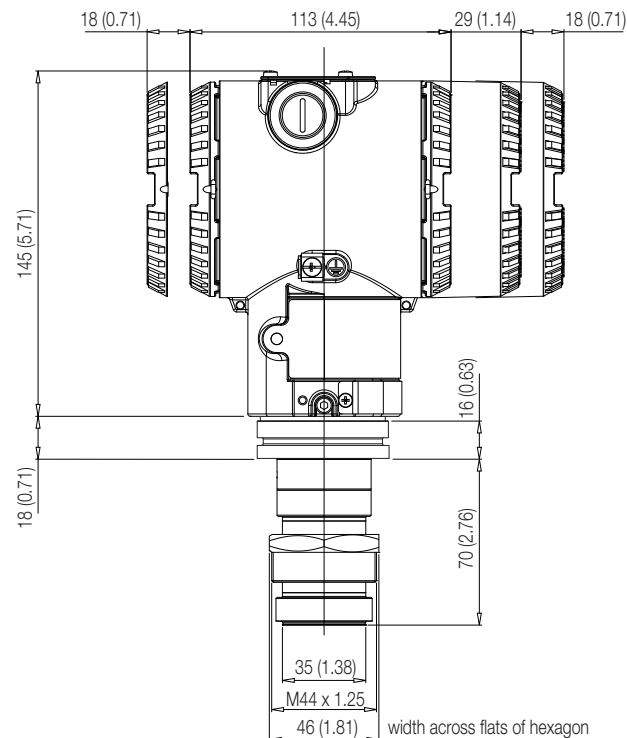

Figure 28: S26KN with M44 x 1.5 threaded spud connection

### Welding procedure for sanitary and Pulp&Paper spuds

1. Using appropriate size hole saw, cut a hole in the process vessel to accept the spud. The hole should couple with the spud perfectly.
2. Remove the weld spud from the transmitter and secondly the PTFE gasket from the weld spud (if any).
3. Position the weld spud in the vessel hole and start welding. For this important phase, please look at and follow the welding sequence (see figure below).
4. Cool each section properly before proceeding to the next section.
5. Use between 100 and 150 amps. and adjust the amperage, if needed, for spud penetration.
6. After the weld spud has cooled, install the PTFE gasket into the weld spud. Ensure the gasket is properly positioned within the weld spud; improper placement can cause a process leak.
7. Position the transmitter into the spud and engage the threads. Rotate the transmitter and thread it completely.
8. Tighten the transmitter or, if in case of pulp and paper cylindrical spud, install the needed bolt(s).

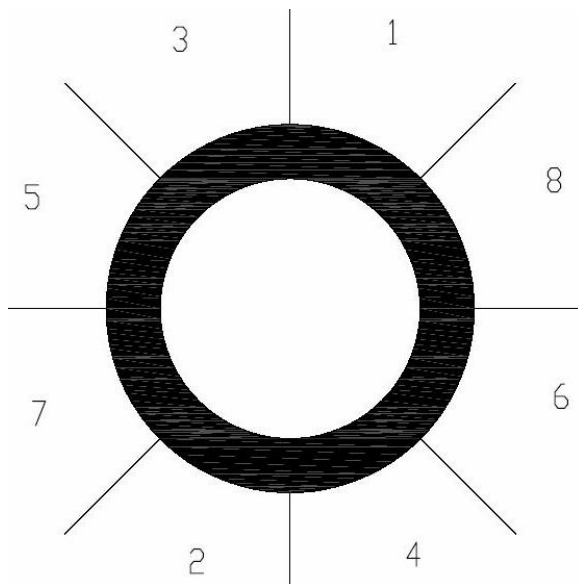

Figure 29: Welding sequence for spuds

### Sanitary spuds (3-A recommendations)

Use of proper procedures and fixtures permits the flanges to be welded to the maximum wall thickness.

The recommended minimum radius of curvature of the tank is 0.91 m (3 feet).

The spud has to be welded so that the welding surface remains smooth and without irregularities where dirt can lodge. The spud leak detection hole has to be positioned at the bottom of the spud.

For sanitary spud welding procedure, please refer to the following figure.

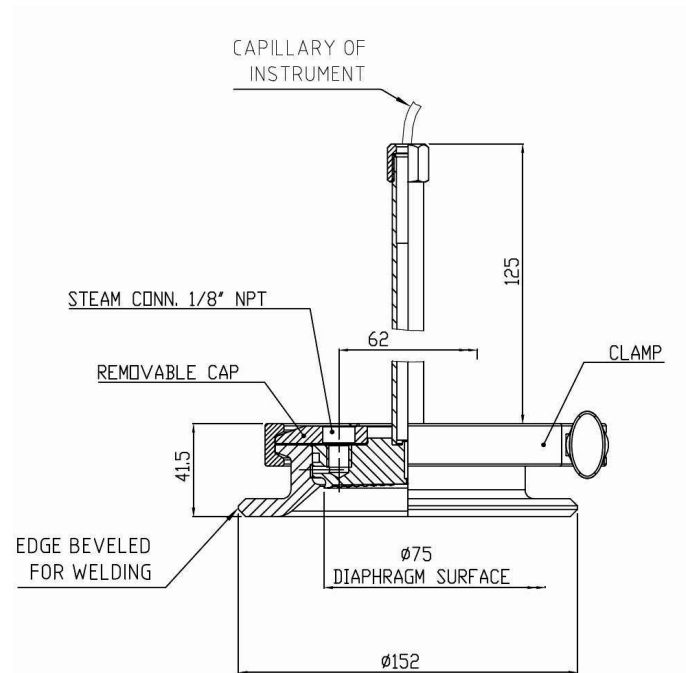

Figure 30: Sanitary spud and welding point

## IMPORTANT

Users should install spuds carefully. Please follow the notes below:

- Position inside gasket (if any) perfectly in order to avoid process leaks.
- Improper installation may result in spud distortion.
- Excessive heat will distort the spud.
- Allow adequate cooling between welding and the following operations.
- Weld the spud properly on tank or vessel walls in order to avoid personal injury or plant damage.

## Ordering Information

### Basic ordering information for model S26RA Rotating flange diaphragm seals (flush and extended) to ASME B16.5

Select one character or set of characters from each category and specify complete catalog number.

| BASE MODEL - 1st to 5th characters  | S | 2 | 6 | R | A               | X        | XX   | X | X | XX | X | X | X | X | X  |
|---|---|---|---|---|-----------------|----------|------|---|---|----|---|---|---|---|----|
| Rotating flange diaphragm seal (Raised face flush and extended) to ASME B16.5 |   |   |   |   |                 |          |      |   |   |    |   |   |   |   |    |
| Transmitter Side of Connection - 6th character                                |   |   |   |   |                 |          |      |   |   |    |   |   |   |   |    |
| High pressure side  |   |   |   |   |                 | H        |      |   |   |    |   |   |   |   |    |
| Low pressure side   |   |   |   |   |                 | L        |      |   |   |    |   |   |   |   |    |
| Mounting Flange Rating / Size - 7th and 8th characters                        |   |   |   |   |                 |          |      |   |   |    |   |   |   |   |    |
| ASME CL 150 / 2 in.   |   |   |   |   |                 |          | E1   |   |   |    |   |   |   |   |    |
| ASME CL 300 / 2 in.   |   |   |   |   |                 |          | E2   |   |   |    |   |   |   |   |    |
| ASME CL 600 / 2 in.   |   |   |   |   |                 |          | E3   |   |   |    |   |   |   |   |    |
| ASME CL 900-1500 / 2 in.  |   |   |   |   |                 |          | E5   |   |   |    |   |   |   |   |    |
| ASME CL 150 / 3 in.   |   |   |   |   |                 |          | G1   |   |   |    |   |   |   |   |    |
| ASME CL 300 / 3 in.   |   |   |   |   |                 |          | G2   |   |   |    |   |   |   |   |    |
| ASME CL 600 / 3 in.   |   |   |   |   |                 |          | G3   |   |   |    |   |   |   |   |    |
| ASME CL 900 / 3 in.   |   |   |   |   |                 |          | G4   |   |   |    |   |   |   |   |    |
| ASME CL 1500 / 3 in.  |   |   |   |   |                 |          | G5   |   |   |    |   |   |   |   |    |
| ASME CL 150 / 4 in.   |   |   |   |   |                 |          | H1   |   |   |    |   |   |   |   |    |
| ASME CL 300 / 4 in.   |   |   |   |   |                 |          | H2   |   |   |    |   |   |   |   |    |
| Mounting Flange Material - 9th character                                      |   |   |   |   |                 |          |      |   |   |    |   |   |   |   |    |
| Carbon steel  |   |   |   |   |                 |          |      |   |   |    |   |   |   |   | C  |
| Dual Grade AISI 316 ss  |   |   |   |   |                 |          |      |   |   |    |   |   |   |   | S  |
| Extensions Length and Material - 10th character                               |   |   |   |   |                 |          |      |   |   |    |   |   |   |   |    |
| Flush   |   |   |   |   |                 |          |      |   |   |    |   |   |   |   | F  |
| 50 mm (2 in.)   |   |   |   |   | AISI 316 L ss   | (Note 1) |      |   |   |    |   |   |   |   | 1  |
| 50 mm (2 in.)   |   |   |   |   | Hastelloy C-276 | (Note 1) |      |   |   |    |   |   |   |   | 2  |
| 100 mm (4 in.)  |   |   |   |   | AISI 316 L ss   | (Note 1) |      |   |   |    |   |   |   |   | 3  |
| 100 mm (4 in.)  |   |   |   |   | Hastelloy C-276 | (Note 1) |      |   |   |    |   |   |   |   | 4  |
| 150 mm (6 in.)  |   |   |   |   | AISI 316 L ss   | (Note 1) |      |   |   |    |   |   |   |   | 5  |
| 150 mm (6 in.)  |   |   |   |   | Hastelloy C-276 | (Note 1) |      |   |   |    |   |   |   |   | 6  |
| Diaphragm Material - 11th and 12th characters                                 |   |   |   |   |                 |          |      |   |   |    |   |   |   |   |    |
| AISI 316 L ss   |   |   |   |   | (Note 2)        |          | NACE |   |   |    |   |   |   |   | SM |
| AISI 316 L ss - Low thickness (not for extended diaphragm)                    |   |   |   |   | (Note 3)        |          | NACE |   |   |    |   |   |   |   | SL |
| Hastelloy C-276   |   |   |   |   |                 |          | NACE |   |   |    |   |   |   |   | HM |
| Hastelloy C-276 - Low thickness (not for extended diaphragm)                  |   |   |   |   | (Note 3)        |          | NACE |   |   |    |   |   |   |   | HL |
| Hastelloy C-2000 (not for extended diaphragm)                                 |   |   |   |   | (Note 3)        |          | NACE |   |   |    |   |   |   |   | MM |
| Hastelloy C-2000 diaphragm and body (not for extended diaphragm)              |   |   |   |   | (Note 3)        |          | NACE |   |   |    |   |   |   |   | ZM |
| Inconel 625 (not for extended diaphragm)                                      |   |   |   |   | (Note 3)        |          | NACE |   |   |    |   |   |   |   | LM |
| Tantalum (not for extended diaphragm)   |   |   |   |   | (Note 3)        |          |      |   |   |    |   |   |   |   | TM |
| AISI 316 L ss gold plated (not for extended diaphragm)                        |   |   |   |   | (Note 3)        |          | NACE |   |   |    |   |   |   |   | NM |
| AISI 316 L ss with PFA anti-stick coating                                     |   |   |   |   | (Note 2)        |          | NACE |   |   |    |   |   |   |   | KM |
| Hastelloy C-276 with PFA anti-stick coating                                   |   |   |   |   |                 |          | NACE |   |   |    |   |   |   |   | YM |
| AISI 316 L ss with PFA coating anti-corrosion and anti-stick                  |   |   |   |   | (Note 2)        |          | NACE |   |   |    |   |   |   |   | WM |
| Diaflex (AISI with anti-abrasion treatment)                                   |   |   |   |   | (Note 2)        |          | NACE |   |   |    |   |   |   |   | FM |
| Superduplex ss (UNS S32750 to ASTM SA479) (not for extended diaphragm)        |   |   |   |   | (Note 3)        |          | NACE |   |   |    |   |   |   |   | EM |
| Monel (not for extended diaphragm)  |   |   |   |   | (Note 3)        |          | NACE |   |   |    |   |   |   |   | GM |

continued  
see next page

|  |                                  | S 2 6 R A X X X X X X X X | X | X | X | X | X | X | X |
|--|----------------------------------|---------------------------|---|---|---|---|---|---|---|
| Seal Surface Finish - 13th character           |                                  |                           |   |   |   |   |   |   |   |
| Serrated                                       | (Note 4)                         | 1                         |   |   |   |   |   |   |   |
| Smooth   | (Note 15)                        | 2                         |   |   |   |   |   |   |   |
| Capillary Protection - 14th character          |                                  |                           |   |   |   |   |   |   |   |
| AISI 316 L ss armour                           |                                  |                           |   |   | A |   |   |   |   |
| AISI 316 L ss armour with PVC protective cover |                                  |                           |   |   | B |   |   |   |   |
| Extension tube for direct mount seal           | (Note 5)                         |                           |   |   | N |   |   |   |   |
| Capillary Length m (Feet) - 15th character     |                                  |                           |   |   |   |   |   |   |   |
| Direct-mount construction                      | (Note 6)                         |                           |   |   |   | 1 |   |   |   |
| 1 (3)  | (Note 7)                         |                           |   |   |   | A |   |   |   |
| 1.5 (5)  | (Note 7)                         |                           |   |   |   | B |   |   |   |
| 2 (7)  | (Note 7)                         |                           |   |   |   | C |   |   |   |
| 2.5 (8)  | (Note 7)                         |                           |   |   |   | D |   |   |   |
| 3 (10)   | (Note 7)                         |                           |   |   |   | E |   |   |   |
| 3.5 (12)                                       | (Note 7)                         |                           |   |   |   | F |   |   |   |
| 4 (13)   | (Note 7)                         |                           |   |   |   | G |   |   |   |
| 4.5 (15)                                       | (Note 7)                         |                           |   |   |   | H |   |   |   |
| 5 (17)   | (Note 7)                         |                           |   |   |   | J |   |   |   |
| 5.5 (18)                                       | (Note 7)                         |                           |   |   |   | K |   |   |   |
| 6 (20)   | (Note 7)                         |                           |   |   |   | L |   |   |   |
| 6.5 (22)                                       | (Note 7)                         |                           |   |   |   | M |   |   |   |
| 7 (23.5)                                       | (Note 7)                         |                           |   |   |   | N |   |   |   |
| 7.5 (25)                                       | (Note 7)                         |                           |   |   |   | P |   |   |   |
| 8 (27)   | (Note 7)                         |                           |   |   |   | Q |   |   |   |
| 9 (30)   | (Note 7)                         |                           |   |   |   | R |   |   |   |
| 10 (33)  | (Note 7)                         |                           |   |   |   | S |   |   |   |
| 12 (40)  | (Note 7)                         |                           |   |   |   | T |   |   |   |
| 14 (47)  | (Note 7)                         |                           |   |   |   | U |   |   |   |
| 16 (53)  | (Note 7)                         |                           |   |   |   | V |   |   |   |
| Fill Fluid - 16th character                    |                                  |                           |   |   |   |   |   |   |   |
| Silicone oil PMX 200 10 cSt                    | (-40 to 250 °C; -40 to 480 °F)   |                           |   |   |   |   | S |   |   |
| Silicone oil Baysilone PD5 5 cSt               | (-85 to 250 °C; -121 to 480 °F)  |                           |   |   |   |   | P |   |   |
| Inert oil - Galden G5                          | (Oxygen service)                 | (Note 8)                  |   |   |   |   | N |   |   |
| Silicone oil for high temperature              | (-10 to 375 °C; 14 to 707 °F)    |                           |   |   |   |   | G |   |   |
| Silicone polymer Syltherm XLT                  | (-100 to 100 °C; -148 to 212 °F) |                           |   |   |   |   | C |   |   |
| Mineral oil Esso Marcol 152                    | (FDA approved)                   | (Note 9)                  |   |   |   |   | W |   |   |
| Vegetable oil Neobee M-20                      | (FDA approved)                   | (Note 9)                  |   |   |   |   | A |   |   |
| Glycerin-water 70%                             | (FDA approved)                   | (Note 9)                  |   |   |   |   | B |   |   |

continued  
see next page

## ...Ordering Information

### ...Basic ordering information for model S26RA Rotating flange diaphragm seals (flush and extended) to ASME B16.5

...Select one character or set of characters from each category and specify complete catalog number.

| S 2 6 R A X X X X X X X X X X                   |                |      | X | X | X |
|---|----------------|------|---|---|---|
| Flushing Ring: Hole and Thread - 17th character |                |      |   |   |   |
| None (TO BE SELECTED FOR EXTENDED VERSIONS)     |                |      | N |   |   |
| 1 hole - 1/2 in. NPT                            | (Note 3)       |      | 2 |   |   |
| 2 holes - 1/2 in. NPT                           | (Note 3)       |      | 3 |   |   |
| 1 hole - 1/4 in. NPT                            | (Note 3)       |      | 4 |   |   |
| 2 holes - 1/4 in. NPT                           | (Note 3)       |      | 5 |   |   |
| Flushing Ring Material - 18th character         |                |      |   |   |   |
| None  | (Note 10)      |      |   | N |   |
| Dual Grade AISI 316 ss                          | (Note 11)      | NACE |   | A |   |
| Hastelloy C-276                                 | (Notes 11, 12) | NACE |   | H |   |
| Flushing Ring: Plug and Gasket - 19th character |                |      |   |   |   |
| No plug - No gasket                             |                |      |   |   | N |
| No plug - garlock                               | (Note 11)      |      |   |   | A |
| No plug - PTFE                                  | (Note 11)      |      |   |   | B |
| No plug - graphite                              | (Note 11)      |      |   |   | C |
| AISI 316 L ss - no gasket                       | (Notes 11, 13) | NACE |   |   | D |
| AISI 316 L ss - garlock                         | (Notes 11, 13) | NACE |   |   | E |
| AISI 316 L ss - PTFE                            | (Notes 11, 13) | NACE |   |   | F |
| AISI 316 L ss - graphite                        | (Notes 11, 13) | NACE |   |   | G |
| Hastelloy C-276 - no gasket                     | (Notes 11, 14) | NACE |   |   | H |
| Hastelloy C-276 - garlock                       | (Notes 11, 14) | NACE |   |   | L |
| Hastelloy C-276 - PTFE                          | (Notes 11, 14) | NACE |   |   | M |
| Hastelloy C-276 - graphite                      | (Notes 11, 14) | NACE |   |   | P |

- Note 1: Not available with mounting flange rating code E3, E5, G3, G4, G5
- Note 2: Not available with extensions length and material code 2, 4, 6
- Note 3: Not available with extensions length and material code 1, 2, 3, 4, 5, 6
- Note 4: Not available with diaphragm material code MM, LM, TM, NM, KM, YM, WM
- Note 5: Not available with transmitter side of connection code L
- Note 6: Not available with capillary protection code A, B
- Note 7: Not available with capillary protection code N
- Note 8: Suitable for oxygen service
- Note 9: Suitable for food application
- Note 10: Not available with Flushing ring: hole and thread code 2, 3, 4, 5
- Note 11: Not available with Flushing ring: hole and thread code N
- Note 12: Not available with Seal surface finish code 1
- Note 13: Not available with Hastelloy C-276 flushing ring material code H
- Note 14: Not available with AISI 316 L flushing ring material code A
- Note 15: Not available with diaphragm material code ZM

**Basic ordering information for model S26RE Rotating flange diaphragm seals (flush and extended) to EN 1092-1**

Select one character or set of characters from each category and specify complete catalog number.

| BASE MODEL - 1st to 5th characters                                     | S 2 6 R E |  |                 |          |  | X | XX   | X | X | XX | X | X | X | X | X  |
|--|-----------|--|-----------------|----------|--|---|------|---|---|----|---|---|---|---|----|
| Rotating flange diaphragm seal (flush and extended) to EN 1092-1       |           |  |                 |          |  |   |      |   |   |    |   |   |   |   |    |
| Transmitter Side of Connection - 6th character                         |           |  |                 |          |  |   |      |   |   |    |   |   |   |   |    |
| High pressure side   |           |  |                 |          |  | H |      |   |   |    |   |   |   |   |    |
| Low pressure side  |           |  |                 |          |  | L |      |   |   |    |   |   |   |   |    |
| Mounting Flange Rating / Size - 7th and 8th characters                 |           |  |                 |          |  |   |      |   |   |    |   |   |   |   |    |
| PN 16 - 40 / DN 50   |           |  |                 |          |  |   | N2   |   |   |    |   |   |   |   |    |
| PN 63 / DN 50  |           |  |                 |          |  |   | N3   |   |   |    |   |   |   |   |    |
| PN 100 / DN 50   |           |  |                 |          |  |   | N4   |   |   |    |   |   |   |   |    |
| PN 16 / DN 80  |           |  |                 |          |  |   | P1   |   |   |    |   |   |   |   |    |
| PN 40 / DN 80  |           |  |                 |          |  |   | P2   |   |   |    |   |   |   |   |    |
| PN 63 / DN 80  |           |  |                 |          |  |   | P3   |   |   |    |   |   |   |   |    |
| PN 100 / DN 80   |           |  |                 |          |  |   | P4   |   |   |    |   |   |   |   |    |
| PN 16 / DN 100   |           |  |                 |          |  |   | Q1   |   |   |    |   |   |   |   |    |
| PN 40 / DN 100   |           |  |                 |          |  |   | Q2   |   |   |    |   |   |   |   |    |
| Mounting Flange Material - 9th character                               |           |  |                 |          |  |   |      |   |   |    |   |   |   |   |    |
| Carbon steel   |           |  |                 |          |  |   |      |   |   |    |   |   |   |   | C  |
| AISI 316 ss  |           |  |                 |          |  |   |      |   |   |    |   |   |   |   | S  |
| Extensions Length and Material - 10th character                        |           |  |                 |          |  |   |      |   |   |    |   |   |   |   |    |
| Flush  |           |  |                 |          |  |   |      |   |   |    |   |   |   |   | F  |
| 50 mm. (2 in.)   |           |  | AISI 316 L ss   | (Note 1) |  |   |      |   |   |    |   |   |   |   | 1  |
| 50 mm. (2 in.)   |           |  | Hastelloy C-276 | (Note 1) |  |   |      |   |   |    |   |   |   |   | 2  |
| 100 mm. (4 in.)  |           |  | AISI 316 L ss   | (Note 1) |  |   |      |   |   |    |   |   |   |   | 3  |
| 100 mm. (4 in.)  |           |  | Hastelloy C-276 | (Note 1) |  |   |      |   |   |    |   |   |   |   | 4  |
| 150 mm. (6 in.)  |           |  | AISI 316 L ss   | (Note 1) |  |   |      |   |   |    |   |   |   |   | 5  |
| 150 mm. (6 in.)  |           |  | Hastelloy C-276 | (Note 1) |  |   |      |   |   |    |   |   |   |   | 6  |
| Diaphragm Material - 11th and 12th characters                          |           |  |                 |          |  |   |      |   |   |    |   |   |   |   |    |
| AISI 316 L ss  |           |  | (Note 2)        |          |  |   | NACE |   |   |    |   |   |   |   | SM |
| AISI 316 L ss - Low thickness (not for extended diaphragm)             |           |  | (Note 3)        |          |  |   | NACE |   |   |    |   |   |   |   | SL |
| Hastelloy C-276  |           |  |                 |          |  |   | NACE |   |   |    |   |   |   |   | HM |
| Hastelloy C-276 - Low thickness (not for extended diaphragm)           |           |  | (Note 3)        |          |  |   | NACE |   |   |    |   |   |   |   | HL |
| Hastelloy C-2000 (not for extended diaphragm)                          |           |  | (Note 3)        |          |  |   | NACE |   |   |    |   |   |   |   | MM |
| Inconel 625 (not for extended diaphragm)                               |           |  | (Note 3)        |          |  |   | NACE |   |   |    |   |   |   |   | LM |
| Tantalum (not for extended diaphragm)                                  |           |  | (Note 3)        |          |  |   |      |   |   |    |   |   |   |   | TM |
| AISI 316 L ss gold plated (not for extended diaphragm)                 |           |  | (Note 3)        |          |  |   | NACE |   |   |    |   |   |   |   | NM |
| AISI 316 L ss with PFA anti-stick coating                              |           |  | (Note 2)        |          |  |   | NACE |   |   |    |   |   |   |   | KM |
| Hastelloy C-276 with PFA anti-stick coating                            |           |  |                 |          |  |   | NACE |   |   |    |   |   |   |   | YM |
| AISI 316 L ss with PFA coating anti-corrosion and anti-stick           |           |  | (Note 2)        |          |  |   | NACE |   |   |    |   |   |   |   | WM |
| Diaflex (AISI with anti-abrasion treatment)                            |           |  | (Note 2)        |          |  |   | NACE |   |   |    |   |   |   |   | FM |
| Superduplex ss (UNS S32750 to ASTM SA479) (not for extended diaphragm) |           |  | (Note 3)        |          |  |   | NACE |   |   |    |   |   |   |   | EM |
| Monel  |           |  | (Note 3)        |          |  |   | NACE |   |   |    |   |   |   |   | GM |

continued  
see next page

## ...Ordering Information

### ...Basic ordering information for model S26RE Rotating flange diaphragm seals (flush and extended) to EN 1092-1

...Select one character or set of characters from each category and specify complete catalog number.

|  |                                  | S | 2 | R | E | X | X | X | X | X | X | X             |
|--|----------------------------------|---|---|---|---|---|---|---|---|---|---|---------------|
| Seal Surface Finish - 13th character           |                                  |   |   |   |   |   |   |   |   |   |   |               |
| Serrated                                       | (Note 4)                         |   |   |   |   |   |   |   |   |   |   |               |
| Smooth   |                                  |   |   |   |   |   |   |   |   |   |   |               |
| Capillary Protection - 14th character          |                                  |   |   |   |   |   |   |   |   |   |   |               |
| AISI 316 L ss armour                           |                                  |   |   |   |   |   |   |   |   |   |   |               |
| AISI 316 L ss armour with PVC protective cover |                                  |   |   |   |   |   |   |   |   |   |   |               |
| Extension tube for direct mount seal           | (Note 5)                         |   |   |   |   |   |   |   |   |   |   |               |
| Capillary Length m (Feet) - 15th character     |                                  |   |   |   |   |   |   |   |   |   |   |               |
| Direct-mount construction                      | (Note 6)                         |   |   |   |   |   |   |   |   |   |   |               |
| 1 (3)  | (Note 7)                         |   |   |   |   |   |   |   |   |   |   |               |
| 1.5 (5)  | (Note 7)                         |   |   |   |   |   |   |   |   |   |   |               |
| 2 (7)  | (Note 7)                         |   |   |   |   |   |   |   |   |   |   |               |
| 2.5 (8)  | (Note 7)                         |   |   |   |   |   |   |   |   |   |   |               |
| 3 (10)   | (Note 7)                         |   |   |   |   |   |   |   |   |   |   |               |
| 3.5 (12)                                       | (Note 7)                         |   |   |   |   |   |   |   |   |   |   |               |
| 4 (13)   | (Note 7)                         |   |   |   |   |   |   |   |   |   |   |               |
| 4.5 (15)                                       | (Note 7)                         |   |   |   |   |   |   |   |   |   |   |               |
| 5 (17)   | (Note 7)                         |   |   |   |   |   |   |   |   |   |   |               |
| 5.5 (18)                                       | (Note 7)                         |   |   |   |   |   |   |   |   |   |   |               |
| 6 (20)   | (Note 7)                         |   |   |   |   |   |   |   |   |   |   |               |
| 6.5 (22)                                       | (Note 7)                         |   |   |   |   |   |   |   |   |   |   |               |
| 7 (23.5)                                       | (Note 7)                         |   |   |   |   |   |   |   |   |   |   |               |
| 7.5 (25)                                       | (Note 7)                         |   |   |   |   |   |   |   |   |   |   |               |
| 8 (27)   | (Note 7)                         |   |   |   |   |   |   |   |   |   |   |               |
| 9 (30)   | (Note 7)                         |   |   |   |   |   |   |   |   |   |   |               |
| 10 (33)  | (Note 7)                         |   |   |   |   |   |   |   |   |   |   |               |
| 12 (40)  | (Note 7)                         |   |   |   |   |   |   |   |   |   |   |               |
| 14 (47)  | (Note 7)                         |   |   |   |   |   |   |   |   |   |   |               |
| 16 (53)  | (Note 7)                         |   |   |   |   |   |   |   |   |   |   |               |
| Fill Fluid - 16th character                    |                                  |   |   |   |   |   |   |   |   |   |   |               |
| Silicone oil PMX 200 10 cSt                    | (-40 to 250 °C; -40 to 480 °F)   |   |   |   |   |   |   |   |   |   |   | S             |
| Silicone oil Baysilone PD5 5 cSt               | (-85 to 250 °C; -121 to 480 °F)  |   |   |   |   |   |   |   |   |   |   | P             |
| Inert oil - Galden G5                          | (Oxygen service)                 |   |   |   |   |   |   |   |   |   |   | (Note 8)<br>N |
| Silicone oil for high temperature              | (-10 to 375 °C; 14 to 707 °F)    |   |   |   |   |   |   |   |   |   |   | G             |
| Silicone polymer Syltherm XLT                  | (-100 to 100 °C; -148 to 212 °F) |   |   |   |   |   |   |   |   |   |   | C             |
| Mineral oil Esso Marcol 152                    | (FDA approved)                   |   |   |   |   |   |   |   |   |   |   | (Note 9)<br>W |
| Vegetable oil Neobee M-20                      | (FDA approved)                   |   |   |   |   |   |   |   |   |   |   | (Note 9)<br>A |
| Glycerin-water 70%                             | (FDA approved)                   |   |   |   |   |   |   |   |   |   |   | (Note 9)<br>B |

continued  
see next page



| S 2 6 R E X X X X X X X X X X                   |                |      | X | X | X |
|---|----------------|------|---|---|---|
| Flushing Ring: Hole and Thread - 17th character |                |      |   |   |   |
| None (TO BE SELECTED FOR EXTENDED VERSIONS)     |                |      | N |   |   |
| 1 hole - 1/2 in. NPT                            | (Note 3)       |      | 2 |   |   |
| 2 holes - 1/2 in. NPT                           | (Note 3)       |      | 3 |   |   |
| 1 hole - 1/4 in. NPT                            | (Note 3)       |      | 4 |   |   |
| 2 holes - 1/4 in. NPT                           | (Note 3)       |      | 5 |   |   |
| Flushing Ring Material - 18th character         |                |      |   |   |   |
| None  | (Note 10)      |      |   | N |   |
| AISI 316 L ss                                   | (Note 11)      | NACE |   | A |   |
| Hastelloy C-276                                 | (Notes 11, 12) | NACE |   | H |   |
| Flushing Ring: Plug and Gasket - 19th character |                |      |   |   |   |
| No plug - No gasket                             |                |      |   |   | N |
| No plug - garlock                               | (Note 11)      |      |   |   | A |
| No plug - PTFE                                  | (Note 11)      |      |   |   | B |
| No plug - graphite                              | (Note 11)      |      |   |   | C |
| AISI 316 L ss - no gasket                       | (Notes 11, 13) | NACE |   |   | D |
| AISI 316 L ss - garlock                         | (Notes 11, 13) | NACE |   |   | E |
| AISI 316 L ss - PTFE                            | (Notes 11, 13) | NACE |   |   | F |
| AISI 316 L ss - graphite                        | (Notes 11, 13) | NACE |   |   | G |
| Hastelloy C-276 - no gasket                     | (Notes 11, 14) | NACE |   |   | H |
| Hastelloy C-276 - garlock                       | (Notes 11, 14) | NACE |   |   | L |
| Hastelloy C-276 - PTFE                          | (Notes 11, 14) | NACE |   |   | M |
| Hastelloy C-276 - graphite                      | (Notes 11, 14) | NACE |   |   | P |

- Note 1: Not available with mounting flange rating code N3, N4, P3, P4
- Note 2: Not available with extensions length and material code 2, 4, 6
- Note 3: Not available with extensions length and material code 1, 2, 3, 4, 5, 6
- Note 4: Not available with diaphragm material code MM, LM, TM, NM, KM, YM, WM
- Note 5: Not available with transmitter side of connection code L
- Note 6: Not available with capillary protection code A, B
- Note 7: Not available with capillary protection code N
- Note 8: Suitable for oxygen service
- Note 9: Suitable for food application
- Note 10: Not available with Flushing ring: hole and thread code 2, 3, 4, 5
- Note 11: Not available with Flushing ring: hole and thread code N
- Note 12: Not available with Seal surface finish code 1
- Note 13: Not available with Hastelloy C-276 flushing ring material code H
- Note 14: Not available with AISI 316 L flushing ring material code A

## Ordering Information

### Basic ordering information for model S26RJ Rotating flange diaphragm seals (flush) to JIS

Select one character or set of characters from each category and specify complete catalog number.

| BASE MODEL - 1st to 5th characters                           | S | 2 | 6 | R | J | X | XX   | X | X | XX | X | X | X | X | X | X | X        |   |
|--|---|---|---|---|---|---|------|---|---|----|---|---|---|---|---|---|----------|---|
| <b>Rotating flange diaphragm seal (flush) to JIS</b>         |   |   |   |   |   |   |      |   |   |    |   |   |   |   |   |   |          |   |
| continued<br>see next page                                   |   |   |   |   |   |   |      |   |   |    |   |   |   |   |   |   |          |   |
| Transmitter Side of Connection - 6th character               |   |   |   |   |   |   |      |   |   |    |   |   |   |   |   |   |          |   |
| High pressure side   |   |   |   |   |   | H |      |   |   |    |   |   |   |   |   |   |          |   |
| Low pressure side  |   |   |   |   |   | L |      |   |   |    |   |   |   |   |   |   |          |   |
| Mounting Flange Rating / Size - 7th and 8th characters       |   |   |   |   |   |   |      |   |   |    |   |   |   |   |   |   |          |   |
| 10K / A50  |   |   |   |   |   |   | B2   |   |   |    |   |   |   |   |   |   |          |   |
| 20K / A50  |   |   |   |   |   |   | B4   |   |   |    |   |   |   |   |   |   |          |   |
| 40K / A50  |   |   |   |   |   |   | B6   |   |   |    |   |   |   |   |   |   |          |   |
| 10K / A80  |   |   |   |   |   |   | C2   |   |   |    |   |   |   |   |   |   |          |   |
| 20K / A80  |   |   |   |   |   |   | C4   |   |   |    |   |   |   |   |   |   |          |   |
| 40K / A80  |   |   |   |   |   |   | C6   |   |   |    |   |   |   |   |   |   |          |   |
| 10K / A100   |   |   |   |   |   |   | D2   |   |   |    |   |   |   |   |   |   |          |   |
| 20K / A100   |   |   |   |   |   |   | D4   |   |   |    |   |   |   |   |   |   |          |   |
| Mounting Flange Material - 9th character                     |   |   |   |   |   |   |      |   |   |    |   |   |   |   |   |   |          |   |
| Carbon steel   |   |   |   |   |   |   |      |   |   |    |   |   |   |   |   |   | C        |   |
| AISI 316 ss  |   |   |   |   |   |   |      |   |   |    |   |   |   |   |   |   | S        |   |
| Extensions Length - 10th character                           |   |   |   |   |   |   |      |   |   |    |   |   |   |   |   |   |          |   |
| Flush  |   |   |   |   |   |   |      |   |   |    |   |   |   |   |   |   | F        |   |
| Diaphragm Material - 11th and 12th characters                |   |   |   |   |   |   |      |   |   |    |   |   |   |   |   |   |          |   |
| AISI 316 L ss  |   |   |   |   |   |   | NACE |   |   |    |   |   |   |   |   |   | SM       |   |
| Hastelloy C-276  |   |   |   |   |   |   | NACE |   |   |    |   |   |   |   |   |   | HM       |   |
| Hastelloy C-2000   |   |   |   |   |   |   | NACE |   |   |    |   |   |   |   |   |   | MM       |   |
| Inconel 625  |   |   |   |   |   |   | NACE |   |   |    |   |   |   |   |   |   | LM       |   |
| Tantalum   |   |   |   |   |   |   |      |   |   |    |   |   |   |   |   |   | TM       |   |
| AISI 316 L ss gold plated                                    |   |   |   |   |   |   | NACE |   |   |    |   |   |   |   |   |   | NM       |   |
| AISI 316 L ss with PFA anti-stick coating                    |   |   |   |   |   |   | NACE |   |   |    |   |   |   |   |   |   | KM       |   |
| Hastelloy C-276 with PFA anti-stick coating                  |   |   |   |   |   |   | NACE |   |   |    |   |   |   |   |   |   | YM       |   |
| AISI 316 L ss with PFA coating anti-corrosion and anti-stick |   |   |   |   |   |   | NACE |   |   |    |   |   |   |   |   |   | WM       |   |
| Superduplex ss (UNS S32750 to ASTM SA479)                    |   |   |   |   |   |   | NACE |   |   |    |   |   |   |   |   |   | EM       |   |
| Seal Surface Finish - 13th character                         |   |   |   |   |   |   |      |   |   |    |   |   |   |   |   |   |          |   |
| Serrated   |   |   |   |   |   |   |      |   |   |    |   |   |   |   |   |   | (Note 1) | 1 |
| Smooth   |   |   |   |   |   |   |      |   |   |    |   |   |   |   |   |   |          | 2 |
| Capillary Protection - 14th character                        |   |   |   |   |   |   |      |   |   |    |   |   |   |   |   |   |          |   |
| AISI 316 L ss armour   |   |   |   |   |   |   |      |   |   |    |   |   |   |   |   |   |          | A |
| AISI 316 L ss armour with PVC protective cover               |   |   |   |   |   |   |      |   |   |    |   |   |   |   |   |   |          | B |
| Extension tube for direct mount seal                         |   |   |   |   |   |   |      |   |   |    |   |   |   |   |   |   | (Note 2) | N |

|  |                                  | S 2 6 R J X X X X X X X X | X | X | X | X | X |
|--|----------------------------------|---------------------------|---|---|---|---|---|
| <b>Capillary Length m (Feet) - 15th character</b>      |                                  |                           |   |   |   |   |   |
| Direct-mount construction                              | (Note 3)                         |                           | 1 |   |   |   |   |
| 1 (3)  | (Note 4)                         |                           | A |   |   |   |   |
| 1.5 (5)  | (Note 4)                         |                           | B |   |   |   |   |
| 2 (7)  | (Note 4)                         |                           | C |   |   |   |   |
| 2.5 (8)  | (Note 4)                         |                           | D |   |   |   |   |
| 3 (10)   | (Note 4)                         |                           | E |   |   |   |   |
| 3.5 (12)   | (Note 4)                         |                           | F |   |   |   |   |
| 4 (13)   | (Note 4)                         |                           | G |   |   |   |   |
| 4.5 (15)   | (Note 4)                         |                           | H |   |   |   |   |
| 5 (17)   | (Note 4)                         |                           | J |   |   |   |   |
| 5.5 (18)   | (Note 4)                         |                           | K |   |   |   |   |
| 6 (20)   | (Note 4)                         |                           | L |   |   |   |   |
| 6.5 (22)   | (Note 4)                         |                           | M |   |   |   |   |
| 7 (23.5)   | (Note 4)                         |                           | N |   |   |   |   |
| 7.5 (25)   | (Note 4)                         |                           | P |   |   |   |   |
| 8 (27)   | (Note 4)                         |                           | Q |   |   |   |   |
| 9 (30)   | (Note 4)                         |                           | R |   |   |   |   |
| 10 (33)  | (Note 4)                         |                           | S |   |   |   |   |
| 12 (40)  | (Note 4)                         |                           | T |   |   |   |   |
| 14 (47)  | (Note 4)                         |                           | U |   |   |   |   |
| 16 (53)  | (Note 4)                         |                           | V |   |   |   |   |
| <b>Fill Fluid - 16th character</b>                     |                                  |                           |   |   |   |   |   |
| Silicone oil PMX 200 10 cSt                            | (-40 to 250 °C; -40 to 480 °F)   |                           |   | S |   |   |   |
| Silicone oil Baysilone PD5 5 cSt                       | (-85 to 250 °C; -121 to 480 °F)  |                           |   | P |   |   |   |
| Inert oil - Galden G5                                  | (Oxygen service)                 | (Note 5)                  |   | N |   |   |   |
| Silicone oil for high temperature                      | (-10 to 375 °C; 14 to 707 °F)    |                           |   | G |   |   |   |
| Silicone polymer Syltherm XLT                          | (-100 to 100 °C; -148 to 212 °F) |                           |   | C |   |   |   |
| Mineral oil Esso Marcol 152                            | (FDA approved)                   | (Note 6)                  |   | W |   |   |   |
| Vegetable oil Neobee M-20                              | (FDA approved)                   | (Note 6)                  |   | A |   |   |   |
| Glycerin-water 70%                                     | (FDA approved)                   | (Note 6)                  |   | B |   |   |   |
| <b>Flushing Ring: Hole and Thread - 17th character</b> |                                  |                           |   |   |   |   |   |
| None   |                                  |                           |   |   |   | N |   |
| <b>Flushing Ring Material - 18th character</b>         |                                  |                           |   |   |   |   |   |
| None   |                                  |                           |   |   |   |   | N |
| <b>Flushing Ring: Plug and Gasket - 19th character</b> |                                  |                           |   |   |   |   |   |
| None   |                                  |                           |   |   |   |   | N |

Note 1: Not available with diaphragm material code HM, MM, LM, TN, NM, KM, YM, WM  
 Note 2: Not available with transmitter side of connection code L  
 Note 3: Not available with capillary protection code A, B  
 Note 4: Not available with capillary protection code N  
 Note 5: Suitable for oxygen service  
 Note 6: Suitable for food application



|   |                                  | S 2 6 R R X X X X X X X X X X | X | X | X | X | X |
|---|----------------------------------|-------------------------------|---|---|---|---|---|
| Capillary Length m (Feet) - 15th character      |                                  |                               |   |   |   |   |   |
| Direct-mount construction                       | (Note 2)                         |                               | 1 |   |   |   |   |
| 1 (3)   | (Note 3)                         |                               | A |   |   |   |   |
| 1.5 (5)   | (Note 3)                         |                               | B |   |   |   |   |
| 2 (7)   | (Note 3)                         |                               | C |   |   |   |   |
| 2.5 (8)   | (Note 3)                         |                               | D |   |   |   |   |
| 3 (10)  | (Note 3)                         |                               | E |   |   |   |   |
| 3.5 (12)  | (Note 3)                         |                               | F |   |   |   |   |
| 4 (13)  | (Note 3)                         |                               | G |   |   |   |   |
| 4.5 (15)  | (Note 3)                         |                               | H |   |   |   |   |
| 5 (17)  | (Note 3)                         |                               | J |   |   |   |   |
| 5.5 (18)  | (Note 3)                         |                               | K |   |   |   |   |
| 6 (20)  | (Note 3)                         |                               | L |   |   |   |   |
| 6.5 (22)  | (Note 3)                         |                               | M |   |   |   |   |
| 7 (23.5)  | (Note 3)                         |                               | N |   |   |   |   |
| 7.5 (25)  | (Note 3)                         |                               | P |   |   |   |   |
| 8 (27)  | (Note 3)                         |                               | Q |   |   |   |   |
| 9 (30)  | (Note 3)                         |                               | R |   |   |   |   |
| 10 (33)   | (Note 3)                         |                               | S |   |   |   |   |
| 12 (40)   | (Note 3)                         |                               | T |   |   |   |   |
| 14 (47)   | (Note 3)                         |                               | U |   |   |   |   |
| 16 (53)   | (Note 3)                         |                               | V |   |   |   |   |
| Fill Fluid - 16th character                     |                                  |                               |   |   |   |   |   |
| Silicone oil PMX 200 10 cSt                     | (-40 to 250 °C; -40 to 480 °F)   |                               |   | S |   |   |   |
| Silicone oil Baysilone PD5 5 cSt                | (-85 to 250 °C; -121 to 480 °F)  |                               |   | P |   |   |   |
| Inert oil - Galden G5                           | (Oxygen service)                 | (Note 4)                      |   | N |   |   |   |
| Silicone oil for high temperature               | (-10 to 375 °C; 14 to 707 °F)    |                               |   | G |   |   |   |
| Silicone polymer Syltherm XLT                   | (-100 to 100 °C; -148 to 212 °F) |                               |   | C |   |   |   |
| Mineral oil Esso Marcol 152                     | (FDA approved)                   | (Note 5)                      |   | W |   |   |   |
| Vegetable oil Neobee M-20                       | (FDA approved)                   | (Note 5)                      |   | A |   |   |   |
| Glycerin-water 70%                              | (FDA approved)                   | (Note 5)                      |   | B |   |   |   |
| Flushing Ring: Hole and Thread - 17th character |                                  |                               |   |   |   |   |   |
| None  |                                  |                               |   |   | N |   |   |
| Flushing Ring Material - 18th character         |                                  |                               |   |   |   |   |   |
| None  |                                  |                               |   |   |   | N |   |
| Flushing Ring: Plug and Gasket - 19th character |                                  |                               |   |   |   |   |   |
| None  |                                  |                               |   |   |   |   | N |

Note 1: Not available with transmitter side of connection code L  
 Note 2: Not available with capillary protection code A, B  
 Note 3: Not available with capillary protection code N  
 Note 4: Suitable for oxygen service  
 Note 5: Suitable for food application

## ...Ordering Information

### Basic ordering information for model S26RH Rotating flange diaphragm seals (flush) to ISO 10423 (API standards)

Select one character or set of characters from each category and specify complete catalog number.

|  |                  |   |      |   |   |    |   |   |   |   |   |   |   |   |
|--|------------------|---|------|---|---|----|---|---|---|---|---|---|---|---|
| <b>BASE MODEL - 1st to 5th characters</b>                  | <b>S 2 6 R H</b> | X | XX   | X | X | XX | X | X | X | X | X | X | X | X |
| <b>Rotating flange diaphragm seal (flush) to ISO 10423</b> |                  |   |      |   |   |    |   |   |   |   |   |   |   |   |
| Transmitter Side of Connection - 6th character             |                  |   |      |   |   |    |   |   |   |   |   |   |   |   |
| High pressure side   |                  | H |      |   |   |    |   |   |   |   |   |   |   |   |
| Low pressure side  |                  | L |      |   |   |    |   |   |   |   |   |   |   |   |
| Size / Rating - 7th and 8th characters                     |                  |   |      |   |   |    |   |   |   |   |   |   |   |   |
| ISO 10423 1 13/16 in. / API 10000 (69 MPa)                 |                  |   | R1   |   |   |    |   |   |   |   |   |   |   |   |
| ISO 10423 1 13/16 in. / API 15000 (103.5 MPa)              |                  |   | R2   |   |   |    |   |   |   |   |   |   |   |   |
| ISO 10423 2 1/16 in. / API 10000 (69 MPa)                  |                  |   | S1   |   |   |    |   |   |   |   |   |   |   |   |
| ISO 10423 2 1/16 in. / API 15000 (103.5 MPa)               |                  |   | S2   |   |   |    |   |   |   |   |   |   |   |   |
| Mounting Flange Material - 9th character                   |                  |   |      |   |   |    |   |   |   |   |   |   |   |   |
| AISI 316 ss  |                  |   |      | S |   |    |   |   |   |   |   |   |   |   |
| Extensions Length - 10th character                         |                  |   |      |   |   |    |   |   |   |   |   |   |   |   |
| Flush  |                  |   |      |   | F |    |   |   |   |   |   |   |   |   |
| Diaphragm Material - 11th and 12th characters              |                  |   |      |   |   |    |   |   |   |   |   |   |   |   |
| AISI 316 L ss  |                  |   | NACE |   |   | SM |   |   |   |   |   |   |   |   |
| Hastelloy C-276  |                  |   | NACE |   |   | HM |   |   |   |   |   |   |   |   |
| Inconel 625  |                  |   | NACE |   |   | LM |   |   |   |   |   |   |   |   |
| Seal Surface Finish - 13th character                       |                  |   |      |   |   |    |   |   |   |   |   |   |   |   |
| According to ISO 10423                                     |                  |   |      |   |   |    | H |   |   |   |   |   |   |   |
| Capillary Protection - 14th character                      |                  |   |      |   |   |    |   |   |   |   |   |   |   |   |
| AISI 316 L ss armour                                       |                  |   |      |   |   |    |   |   |   |   |   |   | A |   |
| AISI 316 L ss armour with PVC protective cover             |                  |   |      |   |   |    |   |   |   |   |   |   |   | B |
| Extension tube for direct mount seal                       | (Note 1)         |   |      |   |   |    |   |   |   |   |   |   |   | N |

continued  
see next page

|   |   |          | S | 2 | 6 | R | H | X | X | X | X | X | X | X |
|---|---|----------|---|---|---|---|---|---|---|---|---|---|---|---|
| Capillary Length m (Feet) - 15th character      |   |          | X | X | X | X | X | X | X | X | X | X | X | X |
| Direct-mount construction                       | (Note 2)  |          | 1 |   |   |   |   |   |   |   |   |   |   |   |
| 1 (3)   | (Note 3)  |          | A |   |   |   |   |   |   |   |   |   |   |   |
| 1.5 (5)   | (Note 3)  |          | B |   |   |   |   |   |   |   |   |   |   |   |
| 2 (7)   | (Note 3)  |          | C |   |   |   |   |   |   |   |   |   |   |   |
| 2.5 (8)   | (Note 3)  |          | D |   |   |   |   |   |   |   |   |   |   |   |
| 3 (10)  | (Note 3)  |          | E |   |   |   |   |   |   |   |   |   |   |   |
| 3.5 (12)  | (Note 3)  |          | F |   |   |   |   |   |   |   |   |   |   |   |
| 4 (13)  | (Note 3)  |          | G |   |   |   |   |   |   |   |   |   |   |   |
| 4.5 (15)  | (Note 3)  |          | H |   |   |   |   |   |   |   |   |   |   |   |
| 5 (17)  | (Note 3)  |          | J |   |   |   |   |   |   |   |   |   |   |   |
| 5.5 (18)  | ONLY AVAILABLE FOR SIZE 2 1/16 in (code S1, S2) | (Note 3) | K |   |   |   |   |   |   |   |   |   |   |   |
| 6 (20)  | ONLY AVAILABLE FOR SIZE 2 1/16 in (code S1, S2) | (Note 3) | L |   |   |   |   |   |   |   |   |   |   |   |
| 6.5 (22)  | ONLY AVAILABLE FOR SIZE 2 1/16 in (code S1, S2) | (Note 3) | M |   |   |   |   |   |   |   |   |   |   |   |
| 7 (23.5)  | ONLY AVAILABLE FOR SIZE 2 1/16 in (code S1, S2) | (Note 3) | N |   |   |   |   |   |   |   |   |   |   |   |
| 7.5 (25)  | ONLY AVAILABLE FOR SIZE 2 1/16 in (code S1, S2) | (Note 3) | P |   |   |   |   |   |   |   |   |   |   |   |
| 8 (27)  | ONLY AVAILABLE FOR SIZE 2 1/16 in (code S1, S2) | (Note 3) | Q |   |   |   |   |   |   |   |   |   |   |   |
| Fill Fluid - 16th character                     |   |          |   |   |   |   |   |   |   |   |   |   |   |   |
| Silicone oil PMX 200 10 cSt                     | (-40 to 250 °C; -40 to 480 °F)                  |          |   |   |   |   |   |   |   | S |   |   |   |   |
| Silicone oil Baysilone PD5 5 cSt                | (-85 to 250 °C; -121 to 480 °F)                 |          |   |   |   |   |   |   |   | P |   |   |   |   |
| Inert oil - Galden G5                           | (Oxygen service)                                | (Note 4) |   |   |   |   |   |   |   | N |   |   |   |   |
| Silicone oil for high temperature               | (-10 to 375 °C; 14 to 707 °F)                   |          |   |   |   |   |   |   |   | G |   |   |   |   |
| Silicone polymer Syltherm XLT                   | (-100 to 100 °C; -148 to 212 °F)                |          |   |   |   |   |   |   |   | C |   |   |   |   |
| Flushing Ring: Hole and Thread - 17th character |   |          |   |   |   |   |   |   |   |   |   |   |   |   |
| None  |   |          |   |   |   |   |   |   |   |   |   |   | N |   |
| Flushing Ring Material - 18th character         |   |          |   |   |   |   |   |   |   |   |   |   |   |   |
| None  |   |          |   |   |   |   |   |   |   |   |   |   |   | N |
| Flushing Ring: Plug and Gasket - 19th character |   |          |   |   |   |   |   |   |   |   |   |   |   |   |
| None  |   |          |   |   |   |   |   |   |   |   |   |   |   | N |

Note 1: Not available with transmitter side of connection code L  
 Note 2: Not available with capillary protection code A, B  
 Note 3: Not available with capillary protection code N  
 Note 4: Suitable for oxygen service

## ...Ordering Information

### Basic ordering information for model S26FA Fixed flange diaphragm seals (flush and extended) to ASME B16.5

Select one character or set of characters from each category and specify complete catalog number.

| BASE MODEL - 1st to 5th characters                       | S | 2 | 6 | F | A | X             | XX | X         | X | XX | X | X                          | X | X  | X |
|--|---|---|---|---|---|---------------|----|-----------|---|----|---|----------------------------|---|----|---|
| <b>Fixed flange diaphragm seal (flush) to ASME B16.5</b> | S | 2 | 6 | F | A | X             | XX | X         | X | XX | X | X                          | X | X  | X |
| Transmitter Side of Connection - 6th character           |   |   |   |   |   |               |    |           |   |    |   | continued<br>see next page |   |    |   |
| High pressure side                                       |   |   |   |   |   | H             |    |           |   |    |   |                            |   |    |   |
| Low pressure side  |   |   |   |   |   | L             |    |           |   |    |   |                            |   |    |   |
| Mounting Flange Rating / Size - 7th and 8th characters   |   |   |   |   |   |               |    |           |   |    |   |                            |   |    |   |
| ANSI 150 / 1 in.   |   |   |   |   |   |               |    |           |   |    |   | C1                         |   |    |   |
| ANSI 300 / 1 in.   |   |   |   |   |   |               |    |           |   |    |   | C2                         |   |    |   |
| ANSI 600 / 1 in.   |   |   |   |   |   |               |    |           |   |    |   | C3                         |   |    |   |
| ANSI 150 / 1 1/2 in.                                     |   |   |   |   |   |               |    |           |   |    |   | D1                         |   |    |   |
| ANSI 300 / 1 1/2 in.                                     |   |   |   |   |   |               |    |           |   |    |   | D2                         |   |    |   |
| ANSI 600 / 1 1/2 in.                                     |   |   |   |   |   |               |    |           |   |    |   | D3                         |   |    |   |
| ASME CL 150 / 2 in.                                      |   |   |   |   |   |               |    |           |   |    |   | E1                         |   |    |   |
| ASME CL 300 / 2 in.                                      |   |   |   |   |   |               |    |           |   |    |   | E2                         |   |    |   |
| ASME CL 600 / 2 in.                                      |   |   |   |   |   |               |    |           |   |    |   | E3                         |   |    |   |
| ASME CL 150 / 3 in.                                      |   |   |   |   |   |               |    |           |   |    |   | G1                         |   |    |   |
| ASME CL 300 / 3 in.                                      |   |   |   |   |   |               |    |           |   |    |   | G2                         |   |    |   |
| ASME CL 600 / 3 in.                                      |   |   |   |   |   |               |    |           |   |    |   | G3                         |   |    |   |
| ASME CL 150 / 4 in.                                      |   |   |   |   |   |               |    |           |   |    |   | H1                         |   |    |   |
| Mounting Flange Material - 9th character                 |   |   |   |   |   |               |    |           |   |    |   |                            |   |    |   |
| Dual Grade AISI 316 ss                                   |   |   |   |   |   |               |    |           |   |    |   | S                          |   |    |   |
| Extensions Length and Material - 10th character          |   |   |   |   |   |               |    |           |   |    |   |                            |   |    |   |
| Flush  |   |   |   |   |   |               |    |           |   |    |   | F                          |   |    |   |
| 50 mm. (2 in.)   |   |   |   |   |   | AISI 316 L ss |    | (Note 13) |   |    |   |                            |   | 1  |   |
| 100 mm. (4 in.)  |   |   |   |   |   | AISI 316 L ss |    | (Note 13) |   |    |   |                            |   | 3  |   |
| 150 mm. (6 in.)  |   |   |   |   |   | AISI 316 L ss |    | (Note 13) |   |    |   |                            |   | 5  |   |
| Diaphragm Material - 11th and 12th characters            |   |   |   |   |   |               |    |           |   |    |   |                            |   |    |   |
| AISI 316 L ss  |   |   |   |   |   | (Note 13)     |    | NACE      |   |    |   |                            |   | SM |   |
| AISI 316 L ss - Low thickness                            |   |   |   |   |   | (Note 1)      |    | NACE      |   |    |   |                            |   | SL |   |
| Hastelloy C-276  |   |   |   |   |   | (Note 13)     |    | NACE      |   |    |   |                            |   | HM |   |
| Hastelloy C-276 - Low thickness                          |   |   |   |   |   | (Note 1)      |    | NACE      |   |    |   |                            |   | HL |   |
| Hastelloy C-2000   |   |   |   |   |   | (Note 1, 13)  |    | NACE      |   |    |   |                            |   | MM |   |
| Inconel 625  |   |   |   |   |   | (Note 1, 13)  |    | NACE      |   |    |   |                            |   | LM |   |



|  |                                  | S 2 6 F A X X X X X X X | X | X | X | X | X | X | X                          |
|--|----------------------------------|-------------------------|---|---|---|---|---|---|----------------------------|
| Seal Surface Finish - 13th character           |                                  |                         |   |   |   |   |   |   |                            |
| Serrated                                       | (Note 2)                         | 1                       |   |   |   |   |   |   | continued<br>see next page |
| Smooth   |                                  | 2                       |   |   |   |   |   |   |                            |
| Capillary Protection - 14th character          |                                  |                         |   |   |   |   |   |   |                            |
| AISI 316 L ss armour                           |                                  |                         |   |   | A |   |   |   |                            |
| AISI 316 L ss armour with PVC protective cover |                                  |                         |   |   | B |   |   |   |                            |
| Extension tube for direct mount seal           | (Note 3)                         |                         |   |   | N |   |   |   |                            |
| Capillary Length m (Feet) - 15th character     |                                  |                         |   |   |   |   |   |   |                            |
| Direct-mount construction                      | (Note 4)                         |                         |   |   |   | 1 |   |   |                            |
| 1 (3)  | (Note 5)                         |                         |   |   |   | A |   |   |                            |
| 1.5 (5)  | (Note 5)                         |                         |   |   |   | B |   |   |                            |
| 2 (7)  | (Note 5)                         |                         |   |   |   | C |   |   |                            |
| 2.5 (8)  | (Note 5)                         |                         |   |   |   | D |   |   |                            |
| 3 (10)   | (Note 5)                         |                         |   |   |   | E |   |   |                            |
| 3.5 (12)                                       | (Note 5)                         |                         |   |   |   | F |   |   |                            |
| 4 (13)   | (Note 5)                         |                         |   |   |   | G |   |   |                            |
| 4.5 (15)                                       | (Note 5)                         |                         |   |   |   | H |   |   |                            |
| 5 (17)   | (Note 5)                         |                         |   |   |   | J |   |   |                            |
| 5.5 (18)                                       | (Note 5)                         |                         |   |   |   | K |   |   |                            |
| 6 (20)   | (Note 5)                         |                         |   |   |   | L |   |   |                            |
| 6.5 (22)                                       | (Note 5)                         |                         |   |   |   | M |   |   |                            |
| 7 (23.5)                                       | (Note 5)                         |                         |   |   |   | N |   |   |                            |
| 7.5 (25)                                       | (Note 5)                         |                         |   |   |   | P |   |   |                            |
| 8 (27)   | (Note 5)                         |                         |   |   |   | Q |   |   |                            |
| 9 (30)   | (Note 5)                         |                         |   |   |   | R |   |   |                            |
| 10 (33)  | (Note 5)                         |                         |   |   |   | S |   |   |                            |
| 12 (40)  | (Note 5)                         |                         |   |   |   | T |   |   |                            |
| 14 (47)  | (Notes 1, 5)                     |                         |   |   |   | U |   |   |                            |
| 16 (53)  | (Notes 1, 5)                     |                         |   |   |   | V |   |   |                            |
| Fill Fluid - 16th character                    |                                  |                         |   |   |   |   |   |   |                            |
| Silicone oil PMX 200 10 cSt                    | (-40 to 250 °C; -40 to 480 °F)   |                         |   |   |   |   | S |   |                            |
| Silicone oil Baysilone PD5 5 cSt               | (-85 to 250 °C; -121 to 480 °F)  |                         |   |   |   |   | P |   |                            |
| Inert oil - Galden G5                          | (Oxygen service)                 | (Note 6)                |   |   |   |   | N |   |                            |
| Silicone oil for high temperature              | (-10 to 375 °C; 14 to 707 °F)    |                         |   |   |   |   | G |   |                            |
| Silicone polymer Syltherm XLT                  | (-100 to 100 °C; -148 to 212 °F) |                         |   |   |   |   | C |   |                            |
| Mineral oil Esso Marcol 152                    | (FDA approved)                   | (Note 7)                |   |   |   |   | W |   |                            |
| Vegetable oil Neobee M-20                      | (FDA approved)                   | (Note 7)                |   |   |   |   | A |   |                            |
| Glycerin-water 70%                             | (FDA approved)                   | (Note 7)                |   |   |   |   | B |   |                            |

## ...Ordering Information

### ...Basic ordering information for model S26FA Fixed flange diaphragm seals (flush and extended) to ASME B16.5

| S 2 6 F A X X X X X X X X X X                   |               |      | X | X | X |
|---|---------------|------|---|---|---|
| Flushing Ring: Hole and Thread - 17th character |               |      |   |   |   |
| None  |               |      | N |   |   |
| 1 hole - 1/2 in. NPT                            | (Note 1)      |      | 2 |   |   |
| 2 holes - 1/2 in. NPT                           | (Note 1)      |      | 3 |   |   |
| 1 hole - 1/4 in. NPT                            | (Note 1)      |      | 4 |   |   |
| 2 holes - 1/4 in. NPT                           | (Note 1)      |      | 5 |   |   |
| Flushing Ring Material - 18th character         |               |      |   |   |   |
| None  | (Note 8)      |      |   | N |   |
| Dual Grade AISI 316 ss                          | (Note 9)      | NACE |   | A |   |
| Hastelloy C-276                                 | (Notes 9, 10) | NACE |   | H |   |
| Flushing Ring: Plug and Gasket - 19th character |               |      |   |   |   |
| No plug - No gasket                             |               |      |   |   | N |
| No plug - garlock                               | (Note 9)      |      |   |   | A |
| No plug - PTFE                                  | (Note 9)      |      |   |   | B |
| No plug - graphite                              | (Note 9)      |      |   |   | C |
| AISI 316 L ss - no gasket                       | (Notes 9, 11) | NACE |   |   | D |
| AISI 316 L ss - garlock                         | (Notes 9, 11) | NACE |   |   | E |
| AISI 316 L ss - PTFE                            | (Notes 9, 11) | NACE |   |   | F |
| AISI 316 L ss - graphite                        | (Notes 9, 11) | NACE |   |   | G |
| Hastelloy C-276 - no gasket                     | (Notes 9, 12) | NACE |   |   | H |
| Hastelloy C-276 - garlock                       | (Notes 9, 12) | NACE |   |   | L |
| Hastelloy C-276 - PTFE                          | (Notes 9, 12) | NACE |   |   | M |
| Hastelloy C-276 - graphite                      | (Notes 9, 12) | NACE |   |   | P |

- Note 1: Not available with extensions length and material code 1, 3, 5
- Note 2: Not available with diaphragm material code MM, LM
- Note 3: Not available with transmitter side of connection code L
- Note 4: Not available with capillary protection code A, B
- Note 5: Not available with capillary protection code N
- Note 6: Suitable for oxygen service
- Note 7: Suitable for food application
- Note 8: Not available with Flushing ring: hole and thread code 2, 3, 4, 5
- Note 9: Not available with Flushing ring: hole and thread code N
- Note 10: Not available with Seal surface finish code 1
- Note 11: Not available with Hastelloy C-276 flushing ring material code H
- Note 12: Not available with AISI 316 L flushing ring material code A
- Note 13: Not available with Mounting Flange Rating / Size code C1, C2, C3, D1, D2, D3



## ...Ordering Information

### ...Basic ordering information for model S26FE Fixed flange diaphragm seals (flush and extended) to EN 1092-1

...Select one character or set of characters from each category and specify complete catalog number.

|   |                                  | S | 2 | 6 | F | E | X | X | X | X | X | X | X |
|---|----------------------------------|---|---|---|---|---|---|---|---|---|---|---|---|
| <b>Seal Surface Finish - 13th character</b>       |                                  |   |   |   |   |   |   |   |   |   |   |   |   |
| Serrated  | (Note 2, 20)                     |   |   |   |   |   | 1 |   |   |   |   |   |   |
| Smooth  | (Note 20, 21)                    |   |   |   |   |   | 2 |   |   |   |   |   |   |
| Form E - Spigot type                              | (Notes 1, 3, 16, 22)             |   |   |   |   |   | 4 |   |   |   |   |   |   |
| EN 1092 - B2                                      | (Notes 2, 21, 28)                |   |   |   |   |   | 5 |   |   |   |   |   |   |
| Form D - Groove type                              | (Notes 1, 3, 4, 16)              |   |   |   |   |   | 6 |   |   |   |   |   |   |
| <b>Capillary Protection - 14th character</b>      |                                  |   |   |   |   |   |   |   |   |   |   |   |   |
| AISI 316 L ss armour                              | (Note 22, 24)                    |   |   |   |   |   |   |   |   |   |   |   |   |
| AISI 316 L ss armour with PVC protective cover    | (Note 22, 24)                    |   |   |   |   |   |   |   |   |   |   |   |   |
| Extension tube for direct mount seal              | (Note 5)                         |   |   |   |   |   |   |   |   |   |   |   |   |
| <b>Capillary Length m (Feet) - 15th character</b> |                                  |   |   |   |   |   |   |   |   |   |   |   |   |
| Direct-mount construction                         | (Note 6)                         |   |   |   |   |   |   |   |   |   |   |   |   |
| 1 (3)   | (Note 7, 22)                     |   |   |   |   |   |   |   |   |   |   |   |   |
| 1.5 (5)   | (Note 7, 22)                     |   |   |   |   |   |   |   |   |   |   |   |   |
| 2 (7)   | (Note 7, 22)                     |   |   |   |   |   |   |   |   |   |   |   |   |
| 2.5 (8)   | (Note 7, 22)                     |   |   |   |   |   |   |   |   |   |   |   |   |
| 3 (10)  | (Note 7, 22)                     |   |   |   |   |   |   |   |   |   |   |   |   |
| 3.5 (12)  | (Note 7, 22, 25)                 |   |   |   |   |   |   |   |   |   |   |   |   |
| 4 (13)  | (Note 7, 22, 25)                 |   |   |   |   |   |   |   |   |   |   |   |   |
| 4.5 (15)  | (Note 7, 22, 25)                 |   |   |   |   |   |   |   |   |   |   |   |   |
| 5 (17)  | (Note 7, 22, 25)                 |   |   |   |   |   |   |   |   |   |   |   |   |
| 5.5 (18)  | (Note 7, 22, 25)                 |   |   |   |   |   |   |   |   |   |   |   |   |
| 6 (20)  | (Note 7, 22, 25)                 |   |   |   |   |   |   |   |   |   |   |   |   |
| 6.5 (22)  | (Note 7, 22, 26)                 |   |   |   |   |   |   |   |   |   |   |   |   |
| 7 (23.5)  | (Note 7, 22, 26)                 |   |   |   |   |   |   |   |   |   |   |   |   |
| 7.5 (25)  | (Note 7, 22, 26)                 |   |   |   |   |   |   |   |   |   |   |   |   |
| 8 (27)  | (Note 7, 22, 26)                 |   |   |   |   |   |   |   |   |   |   |   |   |
| 9 (30)  | (Note 7, 22, 26)                 |   |   |   |   |   |   |   |   |   |   |   |   |
| 10 (33)   | (Note 7, 22, 26)                 |   |   |   |   |   |   |   |   |   |   |   |   |
| 12 (40)   | (Note 7, 22, 26)                 |   |   |   |   |   |   |   |   |   |   |   |   |
| 14 (47)   | (Notes 1, 7, 22, 26)             |   |   |   |   |   |   |   |   |   |   |   |   |
| 16 (53)   | (Notes 1, 7, 22, 26)             |   |   |   |   |   |   |   |   |   |   |   |   |
| <b>Fill Fluid - 16th character</b>                |                                  |   |   |   |   |   |   |   |   |   |   |   |   |
| Silicone oil PMX 200 10 cSt                       | (-40 to 250 °C; -40 to 480 °F)   |   |   |   |   |   |   |   |   |   |   |   | S |
| Silicone oil Baysilone PD5 5 cSt                  | (-85 to 250 °C; -121 to 480 °F)  |   |   |   |   |   |   |   |   |   |   |   | P |
| Inert oil - Galden G5                             | (Oxygen service)                 |   |   |   |   |   |   |   |   |   |   |   | N |
| Silicone oil for high temperature                 | (-10 to 375 °C; 14 to 707 °F)    |   |   |   |   |   |   |   |   |   |   |   | G |
| Silicone polymer Syltherm XLT                     | (-100 to 100 °C; -148 to 212 °F) |   |   |   |   |   |   |   |   |   |   |   | C |
| Mineral oil Esso Marcol 152                       | (FDA approved)                   |   |   |   |   |   |   |   |   |   |   |   | W |
| Vegetable oil Neobee M-20                         | (FDA approved)                   |   |   |   |   |   |   |   |   |   |   |   | A |
| Glycerin-water 70%                                | (FDA approved)                   |   |   |   |   |   |   |   |   |   |   |   | B |

continued  
see next page

| S 2 6 F E X X X X X X X X X X                   |                        |      | X | X | X |
|---|------------------------|------|---|---|---|
| Flushing Ring: Hole and Thread - 17th character |                        |      |   |   |   |
| None  |                        |      | N |   |   |
| 1 hole - 1/2 in. NPT                            | (Notes 1, 10, 21, 27)  |      | 2 |   |   |
| 2 holes - 1/2 in. NPT                           | (Notes 1, 10, 21, 27)  |      | 3 |   |   |
| 1 hole - 1/4 in. NPT                            | (Notes 1, 10, 21, 27)  |      | 4 |   |   |
| 2 holes - 1/4 in. NPT                           | (Notes 1, 10, 21, 27)  |      | 5 |   |   |
| Flushing Ring Material - 18th character         |                        |      |   |   |   |
| None  | (Note 11)              |      |   | N |   |
| AISI 316 L ss                                   | (Notes 12, 21, 27)     | NACE |   | A |   |
| Hastelloy C-276                                 | (Notes 12, 13, 21, 27) | NACE |   | H |   |
| Flushing Ring: Plug and Gasket - 19th character |                        |      |   |   |   |
| No plug - No gasket                             |                        |      |   |   | N |
| No plug - garlock                               | (Note 12, 21, 27)      |      |   |   | A |
| No plug - PTFE                                  | (Note 12, 21, 27)      |      |   |   | B |
| No plug - graphite                              | (Note 12, 21, 27)      |      |   |   | C |
| AISI 316 L ss - no gasket                       | (Notes 12, 14, 21, 27) | NACE |   |   | D |
| AISI 316 L ss - garlock                         | (Notes 12, 14, 21, 27) | NACE |   |   | E |
| AISI 316 L ss - PTFE                            | (Notes 12, 14, 21, 27) | NACE |   |   | F |
| AISI 316 L ss - graphite                        | (Notes 12, 14, 21, 27) | NACE |   |   | G |
| Hastelloy C-276 - no gasket                     | (Notes 12, 15, 21, 27) | NACE |   |   | H |
| Hastelloy C-276 - garlock                       | (Notes 12, 15, 21, 27) | NACE |   |   | L |
| Hastelloy C-276 - PTFE                          | (Notes 12, 15, 21, 27) | NACE |   |   | M |
| Hastelloy C-276 - graphite                      | (Notes 12, 15, 21, 27) | NACE |   |   | P |

- Note 1: Not available with extensions length and material code 1, 3, 5
- Note 2: Not available with diaphragm material code MM, LM, TM
- Note 3: Not available with DN 100 size code Q1
- Note 4: Not available with diaphragm material code HM, HL, MM, LM, TM
- Note 5: Not available with transmitter side of connection code L
- Note 6: Not available with capillary protection code A, B
- Note 7: Not available with capillary protection code N
- Note 8: Suitable for oxygen service
- Note 9: Suitable for food application
- Note 10: Not available with Seal surface finish code 4, 5, 6
- Note 11: Not available with Flushing ring: hole and thread code 2, 3, 4, 5
- Note 12: Not available with Flushing ring: hole and thread code N
- Note 13: Not available with Seal surface finish code 1
- Note 14: Not available with Hastelloy C-276 flushing ring material code H
- Note 15: Not available with AISI 316 L flushing ring material code A
- Note 16: Not available with Mounting Flange Rating / Size code L2, L4, M2, M4
- Note 17: Only available with Mounting Flange Rating / Size code L2
- Note 18: Not available with extensions length and material code R
- Note 19: Only available with Mounting Flange Rating / Size code P2, L2
- Note 20: When Mounting Flange Rating / Size code is L2, it is only available with diaphragm material code HL
- Note 21: When Mounting Flange Rating / Size code is P2, L2, it is not available with extensions length and material code R
- Note 22: Not available with diaphragm material code TM
- Note 23: When Mounting Flange Rating / Size code is L2, it is not available with extensions length and material code F
- Note 24: When Seal Surface Finish code is 5, it is only available with Mounting Flange Rating / Size code L2, combined with extensions length and material code R
- Note 25: Only available with Mounting Flange Rating / Size code L4
- Note 26: Only available with Mounting Flange Rating / Size code L2, L4
- Note 27: When Seal Surface Finish code is 5, it is not available with Mounting Flange Rating / Size code L2
- Note 28: Not available with diaphragm material code MM, LM



| S 2 6 M A X X X X X X X                           |                                  |          | X | X | X | X |
|---|----------------------------------|----------|---|---|---|---|
| <b>Capillary Length m (Feet) - 13th character</b> |                                  |          |   |   |   |   |
| Direct-mount construction                         | (Note 2)                         |          | 1 |   |   |   |
| 1 (3)   | (Note 3)                         |          | A |   |   |   |
| 1.5 (5)   | (Note 3)                         |          | B |   |   |   |
| 2 (7)   | (Note 3)                         |          | C |   |   |   |
| 2.5 (8)   | (Note 3)                         |          | D |   |   |   |
| 3 (10)  | (Note 3)                         |          | E |   |   |   |
| 3.5 (12)  | (Note 3)                         |          | F |   |   |   |
| 4 (13)  | (Note 3)                         |          | G |   |   |   |
| 4.5 (15)  | (Note 3)                         |          | H |   |   |   |
| 5 (17)  | (Note 3)                         |          | J |   |   |   |
| 5.5 (18)  | (Note 3)                         |          | K |   |   |   |
| 6 (20)  | (Note 3)                         |          | L |   |   |   |
| 6.5 (22)  | (Note 3)                         |          | M |   |   |   |
| 7 (23.5)  | (Note 3)                         |          | N |   |   |   |
| 7.5 (25)  | (Note 3)                         |          | P |   |   |   |
| 8 (27)  | (Note 3)                         |          | Q |   |   |   |
| 9 (30)  | (Note 3)                         |          | R |   |   |   |
| 10 (33)   | (Note 3)                         |          | S |   |   |   |
| 12 (40)   | (Note 3)                         |          | T |   |   |   |
| <b>Fill Fluid - 14th character</b>                |                                  |          |   |   |   |   |
| Silicone oil PMX 200 10 cSt                       | (-40 to 250 °C; -40 to 480 °F)   |          |   |   | S |   |
| Silicone oil Baysilone PD5 5 cSt                  | (-85 to 250 °C; -121 to 480 °F)  |          |   |   | P |   |
| Inert oil - Galden G5                             | (Oxygen service)                 | (Note 4) |   |   | N |   |
| Silicone oil for high temperature                 | (-10 to 375 °C; 14 to 707 °F)    |          |   |   | G |   |
| Silicone polymer Syltherm XLT                     | (-100 to 100 °C; -148 to 212 °F) |          |   |   | C |   |
| Mineral oil Esso Marcol 152                       | (FDA approved)                   | (Note 5) |   |   | W |   |
| Vegetable oil Neobee M-20                         | (FDA approved)                   | (Note 5) |   |   | A |   |
| Glycerin-water 70%                                | (FDA approved)                   | (Note 5) |   |   | B |   |
| <b>Flushing Connections - 15th character</b>      |                                  |          |   |   |   |   |
| Not required                                      |                                  |          |   |   |   | 1 |
| Provided (with 2 plugs supplied)                  |                                  |          |   |   |   | Q |
| <b>Gasket - 16th character</b>                    |                                  |          |   |   |   |   |
| PTFE  |                                  |          |   |   |   | 2 |
| Viton®  | (Note 6)                         |          |   |   |   | 3 |
| Graphite  | (Note 6)                         |          |   |   |   | 7 |

Note 1: Not available with transmitter side of connection code L

Note 2: Not available with capillary protection code A, B

Note 3: Not available with capillary protection code N

Note 4: Suitable for oxygen service

Note 5: Suitable for food application

Note 6: Not available with diaphragm material code ZM

Note 7: Not available with diaphragm material code SM, HM, MM, LM, TM, NM

## ...Ordering Information

### Basic ordering information for model S26ME Off-line flange diaphragm seal to EN 1092-1

Select one character or set of characters from each category and specify complete catalog number.

| BASE MODEL - 1st to 5th characters                     | S | 2 | 6 | M | E    | X | XX | X | XX | X  | X | X | X | X |
|--|---|---|---|---|------|---|----|---|----|----|---|---|---|---|
| <b>Off-line flange diaphragm seal to EN 1092-1</b>     |   |   |   |   |      |   |    |   |    |    |   |   |   |   |
| Transmitter Side of Connection - 6th character         |   |   |   |   |      |   |    |   |    |    |   |   |   |   |
| High pressure side                                     |   |   |   |   |      | H |    |   |    |    |   |   |   |   |
| Low pressure side                                      |   |   |   |   |      | L |    |   |    |    |   |   |   |   |
| Mounting Flange Rating / Size - 7th and 8th characters |   |   |   |   |      |   |    |   |    |    |   |   |   |   |
| PN 16 - 40 / DN 25                                     |   |   |   |   |      |   | L2 |   |    |    |   |   |   |   |
| PN 16 - 40 / DN 40                                     |   |   |   |   |      |   | M2 |   |    |    |   |   |   |   |
| Mounting Flange Material / Seat Form - 9th character   |   |   |   |   |      |   |    |   |    |    |   |   |   |   |
| AISI 316 L ss / Form B1 - serrated finish              |   |   |   |   | NACE |   |    |   | S  |    |   |   |   |   |
| Hastelloy C-276 / Form B1 - serrated finish            |   |   |   |   | NACE |   |    |   | H  |    |   |   |   |   |
| Diaphragm Material - 10th and 11th characters          |   |   |   |   |      |   |    |   |    |    |   |   |   |   |
| AISI 316 L ss  |   |   |   |   | NACE |   |    |   |    | SM |   |   |   |   |
| Hastelloy C-276  |   |   |   |   | NACE |   |    |   |    | HM |   |   |   |   |
| Hastelloy C-2000                                       |   |   |   |   | NACE |   |    |   |    | MM |   |   |   |   |
| Inconel 625  |   |   |   |   | NACE |   |    |   |    | LM |   |   |   |   |
| Tantalum   |   |   |   |   |      |   |    |   |    | TM |   |   |   |   |
| AISI 316 L ss gold plated                              |   |   |   |   | NACE |   |    |   |    | NM |   |   |   |   |
| Capillary Protection - 12th character                  |   |   |   |   |      |   |    |   |    |    |   |   |   |   |
| AISI 316 L ss armour                                   |   |   |   |   |      |   |    |   |    |    |   |   |   | A |
| AISI 316 L ss armour with PVC protective cover         |   |   |   |   |      |   |    |   |    |    |   |   |   | B |
| Extension tube for direct mount seal                   |   |   |   |   |      |   |    |   |    |    |   |   |   | N |

continued  
see next page



| S 2 6 M E X X X X X X                      |                                  |          | X | X | X | X |
|--|----------------------------------|----------|---|---|---|---|
| Capillary Length m (Feet) - 13th character |                                  |          |   |   |   |   |
| Direct-mount construction                  | (Note 2)                         |          | 1 |   |   |   |
| 1 (3)                                      | (Note 3)                         |          | A |   |   |   |
| 1.5 (5)                                    | (Note 3)                         |          | B |   |   |   |
| 2 (7)                                      | (Note 3)                         |          | C |   |   |   |
| 2.5 (8)                                    | (Note 3)                         |          | D |   |   |   |
| 3 (10)                                     | (Note 3)                         |          | E |   |   |   |
| 3.5 (12)                                   | (Note 3)                         |          | F |   |   |   |
| 4 (13)                                     | (Note 3)                         |          | G |   |   |   |
| 4.5 (15)                                   | (Note 3)                         |          | H |   |   |   |
| 5 (17)                                     | (Note 3)                         |          | J |   |   |   |
| 5.5 (18)                                   | (Note 3)                         |          | K |   |   |   |
| 6 (20)                                     | (Note 3)                         |          | L |   |   |   |
| 6.5 (22)                                   | (Note 3)                         |          | M |   |   |   |
| 7 (23.5)                                   | (Note 3)                         |          | N |   |   |   |
| 7.5 (25)                                   | (Note 3)                         |          | P |   |   |   |
| 8 (27)                                     | (Note 3)                         |          | Q |   |   |   |
| 9 (30)                                     | (Note 3)                         |          | R |   |   |   |
| 10 (33)                                    | (Note 3)                         |          | S |   |   |   |
| 12 (40)                                    | (Note 3)                         |          | T |   |   |   |
| Fill Fluid - 14th character                |                                  |          |   |   |   |   |
| Silicone oil PMX 200 10 cSt                | (-40 to 250 °C; -40 to 480 °F)   |          |   |   | S |   |
| Silicone oil Baysilone PD5 5 cSt           | (-85 to 250 °C; -121 to 480 °F)  |          |   |   | P |   |
| Inert oil - Galden G5                      | (Oxygen service)                 | (Note 4) |   |   | N |   |
| Silicone oil for high temperature          | (-10 to 375 °C; 14 to 707 °F)    |          |   |   | G |   |
| Silicone polymer Syltherm XLT              | (-100 to 100 °C; -148 to 212 °F) |          |   |   | C |   |
| Mineral oil Esso Marcol 152                | (FDA approved)                   | (Note 5) |   |   | W |   |
| Vegetable oil Neobee M-20                  | (FDA approved)                   | (Note 5) |   |   | A |   |
| Glycerin-water 70%                         | (FDA approved)                   | (Note 5) |   |   | B |   |
| Flushing Connections - 15th character      |                                  |          |   |   |   |   |
| Not required                               |                                  |          |   |   |   | 1 |
| Provided (with 2 plugs supplied)           |                                  |          |   |   |   | Q |
| Gasket - 16th character                    |                                  |          |   |   |   |   |
| PTFE                                       |                                  |          |   |   |   | 2 |
| Viton®                                     |                                  |          |   |   |   | 3 |
| Graphite                                   |                                  |          |   |   |   | 7 |

Note 1: Not available with transmitter side of connection code L

Note 2: Not available with capillary protection code A, B

Note 3: Not available with capillary protection code N

Note 4: Suitable for oxygen service

Note 5: Suitable for food application



|  |                                  | S        | 2 | T | T | X | X | X | X |
|--|----------------------------------|----------|---|---|---|---|---|---|---|
| Capillary Length m (Feet) - 13th character |                                  |          |   |   |   |   | X | X | X |
| Direct-mount construction                  | (Note 2)                         |          |   |   |   |   | 1 |   |   |
| 1 (3)                                      | (Note 3)                         |          |   |   |   |   | A |   |   |
| 1.5 (5)                                    | (Note 3)                         |          |   |   |   |   | B |   |   |
| 2 (7)                                      | (Note 3)                         |          |   |   |   |   | C |   |   |
| 2.5 (8)                                    | (Note 3)                         |          |   |   |   |   | D |   |   |
| 3 (10)                                     | (Note 3)                         |          |   |   |   |   | E |   |   |
| 3.5 (12)                                   | (Note 3)                         |          |   |   |   |   | F |   |   |
| 4 (13)                                     | (Note 3)                         |          |   |   |   |   | G |   |   |
| 4.5 (15)                                   | (Note 3)                         |          |   |   |   |   | H |   |   |
| 5 (17)                                     | (Note 3)                         |          |   |   |   |   | J |   |   |
| 5.5 (18)                                   | (Note 3)                         |          |   |   |   |   | K |   |   |
| 6 (20)                                     | (Note 3)                         |          |   |   |   |   | L |   |   |
| 6.5 (22)                                   | (Note 3)                         |          |   |   |   |   | M |   |   |
| 7 (23.5)                                   | (Note 3)                         |          |   |   |   |   | N |   |   |
| 7.5 (25)                                   | (Note 3)                         |          |   |   |   |   | P |   |   |
| 8 (27)                                     | (Note 3)                         |          |   |   |   |   | Q |   |   |
| 9 (30)                                     | (Note 3)                         |          |   |   |   |   | R |   |   |
| 10 (33)                                    | (Note 3)                         |          |   |   |   |   | S |   |   |
| 12 (40)                                    | (Note 3)                         |          |   |   |   |   | T |   |   |
| Fill Fluid - 14th character                |                                  |          |   |   |   |   |   |   |   |
| Silicone oil PMX 200 10 cSt                | (-40 to 250 °C; -40 to 480 °F)   |          |   |   |   |   |   | S |   |
| Silicone oil Baysilone PD5 5 cSt           | (-85 to 250 °C; -121 to 480 °F)  |          |   |   |   |   |   | P |   |
| Inert oil - Galden G5                      | (Oxygen service)                 | (Note 4) |   |   |   |   |   | N |   |
| Silicone oil for high temperature          | (-10 to 375 °C; 14 to 707 °F)    |          |   |   |   |   |   | G |   |
| Silicone polymer Syltherm XLT              | (-100 to 100 °C; -148 to 212 °F) |          |   |   |   |   |   | C |   |
| Mineral oil Esso Marcol 152                | (FDA approved)                   | (Note 5) |   |   |   |   |   | W |   |
| Vegetable oil Neobee M-20                  | (FDA approved)                   | (Note 5) |   |   |   |   |   | A |   |
| Glycerin-water 70%                         | (FDA approved)                   | (Note 5) |   |   |   |   |   | B |   |
| Flushing Connections - 15th character      |                                  |          |   |   |   |   |   |   |   |
| Not required                               |                                  |          |   |   |   |   |   |   | 1 |
| Provided (with 2 plugs supplied)           | (Note 6)                         |          |   |   |   |   |   |   | Q |
| Gasket - 16th character                    |                                  |          |   |   |   |   |   |   |   |
| PTFE                                       |                                  |          |   |   |   |   |   |   | 2 |
| Viton®                                     |                                  |          |   |   |   |   |   |   | 3 |
| Graphite                                   |                                  |          |   |   |   |   |   |   | 7 |

Note 1: Not available with transmitter side of connection code L  
 Note 2: Not available with capillary protection code A, B  
 Note 3: Not available with capillary protection code N  
 Note 4: Suitable for oxygen service  
 Note 5: Suitable for food application  
 Note 6: Not available with size code 5



| S 2 6 S S X X X X X X   |                                  |          | X | X | X |
|---|----------------------------------|----------|---|---|---|
| <b>Fill Fluid - 12th character</b>  |                                  |          |   |   |   |
| Silicone oil PMX 200 10 cSt   | (-40 to 250 °C; -40 to 480 °F)   |          | S |   |   |
| Silicone polymer Syltherm XLT   | (-100 to 100 °C; -148 to 212 °F) |          | C |   |   |
| Mineral oil Esso Marcol 152   | (FDA approved)                   | (Note 6) | W |   |   |
| Vegetable oil Neobee M-20   | (FDA approved)                   | (Note 6) | A |   |   |
| Glycerin-water 70%  | (FDA approved)                   | (Note 6) | B |   |   |
| <b>Clamp/Fittings - 13th character</b>  |                                  |          |   |   |   |
| None  |                                  |          |   |   | 1 |
| 2 in. V-band Clamp (for 2 in. Triclamp)   |                                  |          |   |   | A |
| 3 in. V-band Clamp (for 3 in. Triclamp)   |                                  |          |   |   | B |
| 4 in. V-band Clamp (for 4 in. Triclamp, 4 in. Cherry Burrell, 4 in. Sanitary flush and 4 in. aseptic flanged) |                                  |          |   |   | C |
| 4 in. Tank spud, tank wall up to 4.7mm (0.18) and 4 in. V-band Clamp (for 4 in. Sanitary flush seal)          |                                  |          |   |   | D |
| 4 in. Tank spud, tank wall up to 9.5mm (0.37) and 4 in. V-band Clamp (for 4 in. Sanitary flush seal)          |                                  |          |   |   | E |
| 4 in. schedule 5 V-band clamp (for 4 in. Sanitary extended seal)  |                                  |          |   |   | F |
| Tank spud for 2 in. extension and 4 in. schedule 5 V-band clamp (for 4 in. Sanitary extended 2 in. seal)      |                                  |          |   |   | G |
| Tank spud for 4 in. extension and 4 in. schedule 5 V-band clamp (for 4 in. Sanitary extended 4 in. seal)      |                                  |          |   |   | H |
| Tank spud for 6 in. extension and 4 in. schedule 5 V-band clamp (for 4 in. Sanitary extended 6 in. seal)      |                                  |          |   |   | J |
| Aseptic tank spud (for 4 in. aseptic flanged seal)  |                                  |          |   |   | P |
| <b>Gasket - 14th character</b>  |                                  |          |   |   |   |
| None  |                                  |          |   |   | 1 |
| Ethylene propylene gasket DN100 (for 4 in. Sanitary extended seal) - (EPDM 3-A 18-03 Class II)                |                                  |          |   |   | A |
| Ethylene propylene gasket DN50 (for F50 Union nut seal)   |                                  |          |   |   | C |
| Ethylene propylene gasket DN80 (for F80 Union nut seal)   |                                  |          |   |   | D |
| Ethylene propylene gasket (for 4 in. Sanitary flush and 4 in. aseptic) - (EPDM 3-A 18-03 Class II)            |                                  |          |   |   | G |

- Note 1: Not used
- Note 2: Not available with transmitter side of connection code L
- Note 3: Not available with capillary protection code A, B
- Note 4: Not available with capillary protection code N
- Note 5: Suitable for oxygen service
- Note 6: Suitable for food application



|  |  |                                  | S 2 6 W A X X X X X X X X | X | X | X | X | X                          |
|--|--|----------------------------------|---------------------------|---|---|---|---|----------------------------|
| Capillary Length m (Feet) - 14th character |  |                                  |                           |   |   |   |   |                            |
| 1 (3)                                      |  |                                  |                           | A |   |   |   | continued<br>see next page |
| 1.5 (5)                                    |  |                                  |                           | B |   |   |   |                            |
| 2 (7)                                      |  |                                  |                           | C |   |   |   |                            |
| 2.5 (8)                                    |  |                                  |                           | D |   |   |   |                            |
| 3 (10)                                     |  |                                  |                           | E |   |   |   |                            |
| 3.5 (12)                                   |  |                                  |                           | F |   |   |   |                            |
| 4 (13)                                     |  |                                  |                           | G |   |   |   |                            |
| 4.5 (15)                                   |  |                                  |                           | H |   |   |   |                            |
| 5 (17)                                     |  |                                  |                           | J |   |   |   |                            |
| 5.5 (18)                                   |  |                                  |                           | K |   |   |   |                            |
| 6 (20)                                     |  |                                  |                           | L |   |   |   |                            |
| 6.5 (22)                                   |  |                                  |                           | M |   |   |   |                            |
| 7 (23.5)                                   |  |                                  |                           | N |   |   |   |                            |
| 7.5 (25)                                   |  |                                  |                           | P |   |   |   |                            |
| 8 (27)                                     |  |                                  |                           | Q |   |   |   |                            |
| 9 (30)                                     |  |                                  |                           | R |   |   |   |                            |
| 10 (33)                                    |  |                                  |                           | S |   |   |   |                            |
| 12 (40)                                    |  |                                  |                           | T |   |   |   |                            |
| 14 (47)                                    |  |                                  |                           | U |   |   |   |                            |
| 16 (53)                                    |  |                                  |                           | V |   |   |   |                            |
| Fill Fluid - 15th character                |  |                                  |                           |   |   |   |   |                            |
| Silicone oil PMX 200 10 cSt                |  | (-40 to 250 °C; -40 to 480 °F)   |                           |   | S |   |   |                            |
| Silicone oil Baysilone PD5 5 cSt           |  | (-85 to 250 °C; -121 to 480 °F)  |                           |   | P |   |   |                            |
| Inert oil - Galden G5                      |  | (Oxygen service)                 | (Note 2)                  |   | N |   |   |                            |
| Silicone oil for high temperature          |  | (-10 to 375 °C; 14 to 707 °F)    |                           |   | G |   |   |                            |
| Silicone polymer Syltherm XLT              |  | (-100 to 100 °C; -148 to 212 °F) |                           |   | C |   |   |                            |
| Mineral oil Esso Marcol 152                |  | (FDA approved)                   | (Note 3)                  |   | W |   |   |                            |
| Vegetable oil Neobee M-20                  |  | (FDA approved)                   | (Note 3)                  |   | A |   |   |                            |
| Glycerin-water 70%                         |  | (FDA approved)                   | (Note 3)                  |   | B |   |   |                            |

## ...Ordering Information

### ...Basic ordering information for model S26WA Wafer diaphragm seal to ASME B16.5

...Select one character or set of characters from each category and specify complete catalog number.

| S 2 6 W A X X X X X X X X X X                   |              | X    | X | X |
|---|--------------|------|---|---|
| Flushing Ring: Hole and Thread - 16th character |              |      |   |   |
| None  |              | N    |   |   |
| 1 hole - 1/2 in. NPT                            |              | 2    |   |   |
| 2 holes - 1/2 in. NPT                           |              | 3    |   |   |
| 1 hole - 1/4 in. NPT                            |              | 4    |   |   |
| 2 holes - 1/4 in. NPT                           |              | 5    |   |   |
| Flushing Ring Material - 17th character         |              |      |   |   |
| None  | (Note 4)     |      |   | N |
| AISI 316 L ss                                   | (Note 5)     | NACE |   | A |
| Hastelloy C-276                                 | (Notes 5, 6) | NACE |   | H |
| Flushing Ring: Plug and Gasket - 18th character |              |      |   |   |
| No plug - No gasket                             |              |      |   | N |
| No plug - garlock                               | (Note 5)     |      |   | A |
| No plug - PTFE                                  | (Note 5)     |      |   | B |
| No plug - graphite                              | (Note 5)     |      |   | C |
| AISI 316 L ss - no gasket                       | (Notes 5, 7) | NACE |   | D |
| AISI 316 L ss - garlock                         | (Notes 5, 7) | NACE |   | E |
| AISI 316 L ss - PTFE                            | (Notes 5, 7) | NACE |   | F |
| AISI 316 L ss - graphite                        | (Notes 5, 7) | NACE |   | G |
| Hastelloy C-276 - no gasket                     | (Notes 5, 8) | NACE |   | H |
| Hastelloy C-276 - garlock                       | (Notes 5, 8) | NACE |   | L |
| Hastelloy C-276 - PTFE                          | (Notes 5, 8) | NACE |   | M |
| Hastelloy C-276 - graphite                      | (Notes 5, 8) | NACE |   | P |

Note 1: Not available with diaphragm material code MM, LM, TM, NM, KM, YM, WM

Note 2: Suitable for oxygen service

Note 3: Suitable for food application

Note 4: Not available with Flushing ring: hole and thread code 2, 3, 4, 5

Note 5: Not available with Flushing ring: hole and thread code N

Note 6: Not available with Seal surface finish code 1

Note 7: Not available with Hastelloy C-276 flushing ring material code H

Note 8: Not available with AISI 316 L flushing ring material code A



**Basic ordering information for model S26WE Wafer diaphragm seal to EN 1092-1**

Select one character or set of characters from each category and specify complete catalog number.

| BASE MODEL - 1st to 5th characters                           | S 2 6 W E |  |  |  |  | X | XX | X | XX | X | X | X | X | X |
|--|-----------|--|--|--|--|---|----|---|----|---|---|---|---|---|
| <b>Wafer diaphragm seal to EN 1092-1</b>                     |           |  |  |  |  |   |    |   |    |   |   |   |   |   |
| Transmitter Side of Connection - 6th character               |           |  |  |  |  |   |    |   |    |   |   |   |   |   |
| High pressure side   |           |  |  |  |  | H |    |   |    |   |   |   |   |   |
| Low pressure side  |           |  |  |  |  | L |    |   |    |   |   |   |   |   |
| Mounting Flange Rating / Size - 7th and 8th characters       |           |  |  |  |  |   |    |   |    |   |   |   |   |   |
| EN 1092-1 DN 40  |           |  |  |  |  |   | M5 |   |    |   |   |   |   |   |
| EN 1092-1 DN 50  |           |  |  |  |  |   | N5 |   |    |   |   |   |   |   |
| EN 1092-1 DN 80  |           |  |  |  |  |   | P5 |   |    |   |   |   |   |   |
| Extensions Length and Material - 9th character               |           |  |  |  |  |   |    |   |    |   |   |   |   |   |
| Flush  |           |  |  |  |  |   |    | F |    |   |   |   |   |   |
| Diaphragm Material - 10th and 11th characters                |           |  |  |  |  |   |    |   |    |   |   |   |   |   |
| AISI 316 L ss  | NACE      |  |  |  |  |   |    |   | SM |   |   |   |   |   |
| AISI 316 L ss - Low thickness                                | NACE      |  |  |  |  |   |    |   | SL |   |   |   |   |   |
| Hastelloy C-276  | NACE      |  |  |  |  |   |    |   | HM |   |   |   |   |   |
| Hastelloy C-276 - Low thickness                              | NACE      |  |  |  |  |   |    |   | HL |   |   |   |   |   |
| Hastelloy C-2000   | NACE      |  |  |  |  |   |    |   | MM |   |   |   |   |   |
| Inconel 625  | NACE      |  |  |  |  |   |    |   | LM |   |   |   |   |   |
| Tantalum   |           |  |  |  |  |   |    |   | TM |   |   |   |   |   |
| AISI 316 L ss gold plated                                    | NACE      |  |  |  |  |   |    |   | NM |   |   |   |   |   |
| AISI 316 L ss with PFA anti-stick coating                    | NACE      |  |  |  |  |   |    |   | KM |   |   |   |   |   |
| Hastelloy C-276 with PFA anti-stick coating                  | NACE      |  |  |  |  |   |    |   | YM |   |   |   |   |   |
| AISI 316 L ss with PFA coating anti-corrosion and anti-stick | NACE      |  |  |  |  |   |    |   | WM |   |   |   |   |   |
| Diaflex (AISI with anti-abrasion treatment)                  | NACE      |  |  |  |  |   |    |   | FM |   |   |   |   |   |
| Superduplex ss (UNS S32750 to ASTM SA479)                    | NACE      |  |  |  |  |   |    |   | EM |   |   |   |   |   |
| Monel  | NACE      |  |  |  |  |   |    |   | GM |   |   |   |   |   |
| Seal Surface Finish - 12th character                         |           |  |  |  |  |   |    |   |    |   |   |   |   |   |
| Serrated   | (Note 1)  |  |  |  |  |   |    |   |    |   |   |   |   | 1 |
| Smooth   |           |  |  |  |  |   |    |   |    |   |   |   |   | 2 |
| Form E - Spigot type   | (Note 2)  |  |  |  |  |   |    |   |    |   |   |   |   | 4 |
| Form D - Groove type   | (Note 3)  |  |  |  |  |   |    |   |    |   |   |   |   | 6 |
| Capillary Protection - 13th character                        |           |  |  |  |  |   |    |   |    |   |   |   |   |   |
| AISI 316 L ss armour   |           |  |  |  |  |   |    |   |    |   |   |   |   | A |
| AISI 316 L ss armour with PVC protective cover               |           |  |  |  |  |   |    |   |    |   |   |   |   | B |

continued  
see next page

## ...Ordering Information

### ...Basic ordering information for model S26WE Wafer diaphragm seal to EN 1092-1

Select one character or set of characters from each category and specify complete catalog number.

|  |                                  | S | 2 | 6 | W | E | X | X | X | X | X | X | X | X |
|--|----------------------------------|---|---|---|---|---|---|---|---|---|---|---|---|---|
| Capillary Length m (Feet) - 14th character |                                  |   |   |   |   |   |   |   |   |   |   |   |   |   |
| 1 (3)                                      |                                  |   |   |   |   |   |   |   |   |   |   |   |   |   |
| 1.5 (5)                                    |                                  |   |   |   |   |   |   |   |   |   |   |   |   |   |
| 2 (7)                                      |                                  |   |   |   |   |   |   |   |   |   |   |   |   |   |
| 2.5 (8)                                    |                                  |   |   |   |   |   |   |   |   |   |   |   |   |   |
| 3 (10)                                     |                                  |   |   |   |   |   |   |   |   |   |   |   |   |   |
| 3.5 (12)                                   |                                  |   |   |   |   |   |   |   |   |   |   |   |   |   |
| 4 (13)                                     |                                  |   |   |   |   |   |   |   |   |   |   |   |   |   |
| 4.5 (15)                                   |                                  |   |   |   |   |   |   |   |   |   |   |   |   |   |
| 5 (17)                                     |                                  |   |   |   |   |   |   |   |   |   |   |   |   |   |
| 5.5 (18)                                   |                                  |   |   |   |   |   |   |   |   |   |   |   |   |   |
| 6 (20)                                     |                                  |   |   |   |   |   |   |   |   |   |   |   |   |   |
| 6.5 (22)                                   |                                  |   |   |   |   |   |   |   |   |   |   |   |   |   |
| 7 (23.5)                                   |                                  |   |   |   |   |   |   |   |   |   |   |   |   |   |
| 7.5 (25)                                   |                                  |   |   |   |   |   |   |   |   |   |   |   |   |   |
| 8 (27)                                     |                                  |   |   |   |   |   |   |   |   |   |   |   |   |   |
| 9 (30)                                     |                                  |   |   |   |   |   |   |   |   |   |   |   |   |   |
| 10 (33)                                    |                                  |   |   |   |   |   |   |   |   |   |   |   |   |   |
| 12 (40)                                    |                                  |   |   |   |   |   |   |   |   |   |   |   |   |   |
| 14 (47)                                    |                                  |   |   |   |   |   |   |   |   |   |   |   |   |   |
| 16 (53)                                    |                                  |   |   |   |   |   |   |   |   |   |   |   |   |   |
| Fill Fluid - 15th character                |                                  |   |   |   |   |   |   |   |   |   |   |   |   |   |
| Silicone oil PMX 200 10 cSt                | (-40 to 250 °C; -40 to 480 °F)   |   |   |   |   |   |   |   |   |   |   |   |   | S |
| Silicone oil Baysilone PD5 5 cSt           | (-85 to 250 °C; -121 to 480 °F)  |   |   |   |   |   |   |   |   |   |   |   |   | P |
| Inert oil - Galden G5                      | (Oxygen service)                 |   |   |   |   |   |   |   |   |   |   |   |   | N |
| Silicone oil for high temperature          | (-10 to 375 °C; 14 to 707 °F)    |   |   |   |   |   |   |   |   |   |   |   |   | G |
| Silicone polymer Syltherm XLT              | (-100 to 100 °C; -148 to 212 °F) |   |   |   |   |   |   |   |   |   |   |   |   | C |
| Mineral oil Esso Marcol 152                | (FDA approved)                   |   |   |   |   |   |   |   |   |   |   |   |   | W |
| Vegetable oil Neobee M-20                  | (FDA approved)                   |   |   |   |   |   |   |   |   |   |   |   |   | A |
| Glycerin-water 70%                         | (FDA approved)                   |   |   |   |   |   |   |   |   |   |   |   |   | B |

continued  
see next page

| S 2 6 W E X X X X X X X X X X                   |               |      | X | X | X |
|---|---------------|------|---|---|---|
| Flushing Ring: Hole and Thread - 16th character |               |      |   |   |   |
| None  |               |      | N |   |   |
| 1 hole - 1/2 in. NPT                            | (Note 6)      |      | 2 |   |   |
| 2 holes - 1/2 in. NPT                           | (Note 6)      |      | 3 |   |   |
| 1 hole - 1/4 in. NPT                            | (Note 6)      |      | 4 |   |   |
| 2 holes - 1/4 in. NPT                           | (Note 6)      |      | 5 |   |   |
| Flushing Ring Material - 17th character         |               |      |   |   |   |
| None  | (Note 7)      |      |   | N |   |
| AISI 316 L ss                                   | (Note 8)      | NACE |   | A |   |
| Hastelloy C-276                                 | (Notes 8, 9)  | NACE |   | H |   |
| Flushing Ring: Plug and Gasket - 18th character |               |      |   |   |   |
| No plug - No gasket                             |               |      |   |   | N |
| No plug - garlock                               | (Note 8)      |      |   |   | A |
| No plug - PTFE                                  | (Note 8)      |      |   |   | B |
| No plug - graphite                              | (Note 8)      |      |   |   | C |
| AISI 316 L ss - no gasket                       | (Notes 8, 10) | NACE |   |   | D |
| AISI 316 L ss - garlock                         | (Notes 8, 10) | NACE |   |   | E |
| AISI 316 L ss - PTFE                            | (Notes 8, 10) | NACE |   |   | F |
| AISI 316 L ss - graphite                        | (Notes 8, 10) | NACE |   |   | G |
| Hastelloy C-276 - no gasket                     | (Notes 8, 11) | NACE |   |   | H |
| Hastelloy C-276 - garlock                       | (Notes 8, 11) | NACE |   |   | L |
| Hastelloy C-276 - PTFE                          | (Notes 8, 11) | NACE |   |   | M |
| Hastelloy C-276 - graphite                      | (Notes 8, 11) | NACE |   |   | P |

- Note 1: Not available with diaphragm material code MM, LM, TM, NM, KM, YM, WM
- Note 2: Not available with diaphragm material code SM, HM, MM, LM, TM, NM, KM, YM, WM, FM, EM
- Note 3: Not available with diaphragm material code SM, HM, HL, MM, LM, TM, NM, KM, YM, WM, FM, EM
- Note 4: Suitable for oxygen service
- Note 5: Suitable for food application
- Note 6: Not available with Seal surface finish code 4, 6
- Note 7: Not available with Flushing ring: hole and thread code 2, 3, 4, 5
- Note 8: Not available with Flushing ring: hole and thread code N
- Note 9: Not available with Seal surface finish code 1
- Note 10: Not available with Hastelloy C-276 flushing ring material code H
- Note 11: Not available with AISI 316 L flushing ring material code A

## ...Ordering Information

### Basic ordering information for model S26BN Button type remote diaphragm seal

Select one character or set of characters from each category and specify complete catalog number.

|   |                  |          |          |          |           |          |          |          |          |          |      |    |
|---|------------------|----------|----------|----------|-----------|----------|----------|----------|----------|----------|------|----|
| <b>BASE MODEL - 1st to 5th characters</b>                               | <b>S 2 6 B N</b> | <b>X</b> | <b>X</b> | <b>X</b> | <b>XX</b> | <b>X</b> | <b>X</b> | <b>X</b> | <b>X</b> | <b>X</b> |      |    |
| <b>Button type remote diaphragm seal</b>                                |                  |          |          |          |           |          |          |          |          |          |      |    |
| Transmitter Side of Connection - 6th character                          |                  |          |          |          |           |          |          |          |          |          |      |    |
| High pressure side  |                  |          |          |          |           |          |          |          |          |          | H    |    |
| Size - 7th character  |                  |          |          |          |           |          |          |          |          |          |      |    |
| 1 in.   |                  |          |          |          |           |          |          |          |          |          | M    |    |
| Mounting connection type - 8th character                                |                  |          |          |          |           |          |          |          |          |          |      |    |
| 3 1/4 in. flange extended – type 91                                     |                  |          |          |          |           |          |          |          |          |          | A    |    |
| 3 1/2 in. flange extended – type 91 modified                            |                  |          |          |          |           |          |          |          |          |          | B    |    |
| 1 1/2 in. 16N-2 threaded union – type 92                                |                  |          |          |          |           |          |          |          |          |          | C    |    |
| Bracket – type 89   |                  |          |          |          |           |          |          |          |          |          | D    |    |
| Universal – type 90   |                  |          |          |          |           |          |          |          |          |          | E    |    |
| 1 1/2 in. 12NF threaded union – type 92 modified                        |                  |          |          |          |           |          |          |          |          |          | F    |    |
| Diaphragm Material - 9th and 10th characters                            |                  |          |          |          |           |          |          |          |          |          |      |    |
| Hastelloy C-276   |                  |          |          |          |           |          |          |          |          |          | NACE | HL |
| Capillary Protection - 11th character                                   |                  |          |          |          |           |          |          |          |          |          |      |    |
| AISI 316 L ss armour  |                  |          |          |          |           |          |          |          |          |          | A    |    |
| AISI 316 L ss armour with PVC protective cover                          |                  |          |          |          |           |          |          |          |          |          | B    |    |
| Capillary Length m (Feet) - 12th character                              |                  |          |          |          |           |          |          |          |          |          |      |    |
| 1 (3)   |                  |          |          |          |           |          |          |          |          |          | A    |    |
| 1.5 (5)   |                  |          |          |          |           |          |          |          |          |          | B    |    |
| 2 (7)   |                  |          |          |          |           |          |          |          |          |          | C    |    |
| 2.5 (8)   |                  |          |          |          |           |          |          |          |          |          | D    |    |
| 3 (10)  |                  |          |          |          |           |          |          |          |          |          | E    |    |
| Fill Fluid - 13th character   |                  |          |          |          |           |          |          |          |          |          |      |    |
| Silicone oil PMX 200 10 cSt (-40 to 250 °C; -40 to 480 °F)              |                  |          |          |          |           |          |          |          |          |          | S    |    |
| Silicone oil for high temperature (-10 to 375 °C; 14 to 707 °F)         |                  |          |          |          |           |          |          |          |          |          | G    |    |
| Mineral oil Esso Marcol 152 (FDA approved) (Note 1)                     |                  |          |          |          |           |          |          |          |          |          | W    |    |
| Option - 14th character   |                  |          |          |          |           |          |          |          |          |          |      |    |
| None  |                  |          |          |          |           |          |          |          |          |          | 1    |    |
| Jack out collar for seal removal for process (not for type 89) (Note 2) |                  |          |          |          |           |          |          |          |          |          | 2    |    |
| Gasket - 15th character   |                  |          |          |          |           |          |          |          |          |          |      |    |
| None  |                  |          |          |          |           |          |          |          |          |          | 1    |    |
| Aluminium   |                  |          |          |          |           |          |          |          |          |          | E    |    |
| AISI 316 ss   |                  |          |          |          |           |          |          |          |          |          | F    |    |

Note 1: Suitable for food application

Note 2: Not available with mounting connection types code D

**Basic ordering information for model S26PN Urea service remote diaphragm seal**

Select one character or set of characters from each category and specify complete catalog number.

| BASE MODEL - 1st to 5th characters                              | S | 2 | 6 | P        | N | X | X | X | XX | X | X | X | X |
|---|---|---|---|----------|---|---|---|---|----|---|---|---|---|
| <b>Urea service remote diaphragm seal</b>                       |   |   |   |          |   |   |   |   |    |   |   |   |   |
| Transmitter Side of Connection - 6th character                  |   |   |   |          |   |   |   |   |    |   |   |   |   |
| High pressure side  |   |   |   |          |   | H |   |   |    |   |   |   |   |
| Low pressure side   |   |   |   |          |   | L |   |   |    |   |   |   |   |
| Size / Mounting Flange Rating / Material - 7th character        |   |   |   |          |   |   |   |   |    |   |   |   |   |
| 3 in. / ASME 600 RF integral flange / AISI 316 L ss Urea Grade  |   |   |   |          |   |   | H |   |    |   |   |   |   |
| 2 in. / ASME 2500 threaded flange / Carbon steel                |   |   |   |          |   |   | J |   |    |   |   |   |   |
| Extension length / diameter - 8th character                     |   |   |   |          |   |   |   |   |    |   |   |   |   |
| 40.3 mm (1.59 in.) / 69 mm (2.71 in.)                           |   |   |   | (Note 1) |   |   |   | R |    |   |   |   |   |
| 40.3 mm (1.59 in.) / 94 mm (3.7 in.)                            |   |   |   | (Note 1) |   |   |   | S |    |   |   |   |   |
| 131 mm (5.16 in.) / 37.5 mm (1.47 in.)                          |   |   |   | (Note 2) |   |   |   | T |    |   |   |   |   |
| Diaphragm Material - 9th and 10th characters                    |   |   |   |          |   |   |   |   |    |   |   |   |   |
| AISI 316 L ss Urea Grade  |   |   |   |          |   |   |   |   | SM |   |   |   |   |
| Capillary Protection - 11th character                           |   |   |   |          |   |   |   |   |    |   |   |   |   |
| AISI 316 L ss armour  |   |   |   |          |   |   |   |   |    | A |   |   |   |
| AISI 316 L ss armour with PVC protective cover                  |   |   |   |          |   |   |   |   |    | B |   |   |   |
| Capillary Length m (Feet) - 12th character                      |   |   |   |          |   |   |   |   |    |   |   |   |   |
| 1 (3)   |   |   |   |          |   |   |   |   |    |   |   | A |   |
| 1.5 (5)   |   |   |   |          |   |   |   |   |    |   |   | B |   |
| 2 (7)   |   |   |   |          |   |   |   |   |    |   |   | C |   |
| 2.5 (8)   |   |   |   |          |   |   |   |   |    |   |   | D |   |
| 3 (10)  |   |   |   |          |   |   |   |   |    |   |   | E |   |
| 3.5 (12)  |   |   |   |          |   |   |   |   |    |   |   | F |   |
| 4 (13)  |   |   |   |          |   |   |   |   |    |   |   | G |   |
| 4.5 (15)  |   |   |   |          |   |   |   |   |    |   |   | H |   |
| 5 (17)  |   |   |   |          |   |   |   |   |    |   |   | J |   |
| 5.5 (18)  |   |   |   | (Note 1) |   |   |   |   |    |   |   | K |   |
| 6 (20)  |   |   |   | (Note 1) |   |   |   |   |    |   |   | L |   |
| Fill Fluid - 13th character                                     |   |   |   |          |   |   |   |   |    |   |   |   |   |
| Silicone oil PMX 200 10 cSt (-40 to 250 °C; -40 to 480 °F)      |   |   |   |          |   |   |   |   |    |   |   |   | S |
| Silicone oil for high temperature (-10 to 375 °C; 14 to 707 °F) |   |   |   |          |   |   |   |   |    |   |   |   | G |
| Certification - 14th character                                  |   |   |   |          |   |   |   |   |    |   |   |   |   |
| None  |   |   |   |          |   |   |   |   |    |   |   |   | 1 |
| Huey test   |   |   |   |          |   |   |   |   |    |   |   |   | 3 |

Note 1: Not available with Size/Mounting flange code J

Note 2: Not available with Size/Mounting flange code H

## ...Ordering Information

### Basic ordering information for model S26KN Pulp and paper diaphragm seal

Select one character or set of characters from each category and specify complete catalog number.

| BASE MODEL - 1st to 5th characters   | S 2 6 K N | X | X | XX | X  | X | X | X |
|--|-----------|---|---|----|----|---|---|---|
| <b>Pulp and paper diaphragm seal</b>   |           |   |   |    |    |   |   |   |
| Transmitter Side of Connection - 6th character   |           |   |   |    |    |   |   |   |
| High pressure side   |           | H |   |    |    |   |   |   |
| Size / Mounting connection - 7th character   |           |   |   |    |    |   |   |   |
| 1 in. pulp and paper seal - sealing with gaskets to spud (NOT AVAILABLE WITH SENSOR F)                 |           |   | U |    |    |   |   |   |
| 1 1/2 in. pulp and paper seal - sealing with gasket to spud (NOT AVAILABLE WITH SENSOR S)              |           |   |   | K  |    |   |   |   |
| 1 in. pulp and paper seal with 1 in. NPT male threaded connection (NOT AVAILABLE WITH SENSOR F)        |           |   |   | W  |    |   |   |   |
| 1 1/2 in. pulp and paper seal with 1 1/2 in. NPT male threaded connection                              |           |   |   | Z  |    |   |   |   |
| 1 in. pulp and paper seal with G 1 in. A male threaded connection (NOT AVAILABLE WITH SENSOR F)        |           |   |   | 1  |    |   |   |   |
| 1 1/2 in. pulp and paper seal with G 1 1/2 in. A male threaded connection                              |           |   |   | 2  |    |   |   |   |
| 1 in. pulp and paper seal with ball valve connection (NOT AVAILABLE WITH SENSOR F and 266ART)          |           |   |   | Y  |    |   |   |   |
| 1 1/2 in. pulp and paper seal - sealing with gasket to M44 threaded spud (NOT AVAILABLE WITH SENSOR S) |           |   |   | V  |    |   |   |   |
| Diaphragm Material - 8th and 9th characters  |           |   |   |    |    |   |   |   |
| AISI 316 L ss (Note 1)   |           |   |   |    | SL |   |   |   |
| Hastelloy C-276  |           |   |   |    | HL |   |   |   |
| Diaflex (AISI with anti-abrasion treatment) (Note 1)   |           |   |   |    | FL |   |   |   |
| Capillary Protection - 10th character  |           |   |   |    |    |   |   |   |
| Extension tube for direct mount seal   |           |   |   |    |    | N |   |   |
| Capillary Length m (Feet) - 11th character   |           |   |   |    |    |   |   |   |
| Direct-mount construction  |           |   |   |    |    |   | 1 |   |
| Fill Fluid - 12th character  |           |   |   |    |    |   |   |   |
| Silicone oil PMX 200 10 cSt (-40 to 250 °C; -40 to 480 °F)   |           |   |   |    |    |   |   | S |
| Mineral oil Esso Marcol 152 (FDA approved) (Note 5)  |           |   |   |    |    |   |   | W |
| Clamp/Fittings - 13th character  |           |   |   |    |    |   |   |   |
| Not required   |           |   |   |    |    |   |   | N |
| Weld-on spud and fixing screw for 1 in. pulp & paper seal connection (Note 2)                          |           |   |   |    |    |   |   | C |
| Weld-on threaded spud for 1 1/2 in. pulp & paper seal connection (Note 3)                              |           |   |   |    |    |   |   | D |
| Weld-on spud and fixing screws for 1 1/2 in. pulp & paper seal connection (Note 4)                     |           |   |   |    |    |   |   | F |

Note 1: Not available with connection code Y

Note 2: Suitable ONLY for 1 in. size - sealing with gaskets code U

Note 3: Suitable ONLY for 1-1/2 in. size to M44 threaded spud - sealing with gaskets code V

Note 4: Suitable ONLY for 1-1/2 in. size - sealing with gaskets code K

Note 5: Suitable for food application

## **IMPORTANT REMARK FOR ALL MODELS**

THE SELECTION OF SUITABLE WETTED PARTS AND FILLING FLUID FOR COMPATIBILITY WITH THE PROCESS MEDIA IS A CUSTOMER'S RESPONSIBILITY, IF NOT OTHERWISE NOTIFIED BEFORE MANUFACTURING.

### NACE COMPLIANCE INFORMATION

The materials of constructions comply with metallurgical recommendations of NACE MR0175/ISO 15156 for sour oil field production environments. As specific environmental limits may apply to certain materials, please consult latest standard for further details. AISI 316/316 L, Hastelloy C-276, Monel 400 also conform to NACE MR0103 for sour refining environments.

### Trademarks

- ® Buna-N is a registered trademark of DuPont Dow Elastomers.
- ® FOUNDATION Fieldbus is a registered trademark of FieldComm Group, Austin, Texas, USA
- ® HART is a registered trademark of FieldComm Group, Austin, Texas, USA
- ® Hastelloy is a registered trademark of Haynes International, Inc.
- ® PROFIBUS and PROFIBUS PA are registered trademarks of PROFIBUS & PROFINET International (PI)
- ® Monel is a registered trademark of Special Metals Corporation
- ™ FieldComm Group is a trademark of FieldComm Group, Austin, Texas, USA
- ® PMX 200 and Syltherm are registered trademarks of Dow Corning Corporation
- ® Galden is a registered trademark of Solvay Group
- ® Baysilone is a registered trademark of Bayer
- ® Neobee is a registered trademark Stepan Specialty Products, LCC
- ® Esso Marcol 152 is a registered trademark of Esso Italiana
- ™ Kynar is an Elf Atochem North America Inc. trademark
- ™ Viton is a DuPont de Nemours trademark

## SECTION B - INSTRUCTION MANUAL

### 3 Safety

#### General safety information

The “Safety” section provides an overview of the safety aspects to be observed for operation of the device.

The device has been constructed in accordance with the state of the art and is operationally safe. It has been tested and left the factory in perfect working conditions. The information in the manual, as well as the applicable documentation and certificates, must be observed and followed in order to maintain this condition throughout the period of operation.

Full compliance with the general safety requirements must be observed during operation of the device. In addition to the general information, the individual sections in the manual contain descriptions of processes or procedural instructions with specific safety information.

Only by observing all of the safety information can you reduce to the minimum the risk of hazards for personnel and/or environment. These instructions are intended as an overview and do not contain detailed information on all available models or every conceivable event that may occur during setup, operation, and maintenance work.

For additional information, or in the event of specific problems not covered in detail by these operating instructions, please contact the manufacturer. In addition, ABB declares that the contents of this manual are not part of any prior or existing agreements, commitments, or legal relationships; nor are they intended to amend these.

All obligations of ABB arise from the conditions of the relevant sales agreement, which also contains the solely binding warranty regulations in full. These contractual warranty provisions are neither extended nor limited by the information provided in this manual.

#### **WARNING**

Only qualified and authorized specialist personnel should be charged with installation, electrical connection, commissioning, and maintenance of the transmitter. Qualified personnel are persons who have experience in installation, electrical wiring connection, commissioning, and operation of the transmitter or similar devices, and hold the necessary qualifications such as:

- Training or instruction, i.e., authorization to operate and maintain devices or systems according to safety engineering standards for electrical circuits, high pressures, and aggressive media
- Training or instruction in accordance with safety engineering standards regarding maintenance and use of adequate safety systems.

For safety reasons, ABB draws your attention to the fact that only sufficiently insulated tools conforming to DIN EN 60900 may be used.

Since the transmitter may form part of a safety chain, we recommend replacing the device immediately if any defects are detected. In case of use in Hazardous Area non sparking tools only must be employed.

In addition, you must observe the relevant safety regulations regarding the installation and operation of electrical systems, and the relevant standards, regulations and guidelines about explosion protection.

#### **WARNING**

The device can be operated at high levels of pressure and with aggressive media. As a result, serious injury or significant property damage may occur if this device is operated incorrectly.



## Improper use

It is prohibited to use the device for the following purposes:

- As a climbing aid, e.g., for mounting purposes
- As a support for external loads, e.g., as a support for pipes.
- Adding material, e.g., by painting over the name plate or welding/soldering on parts
- Removing material, e.g., by drilling the housing.

Repairs, alterations, and enhancements, or the installation of replacement parts, are only permissible as far as these are described in the manual. Approval by ABB must be requested for any activities beyond this scope. Repairs performed by ABB-authorized centers are excluded from this.

## Technical limit values

The device is designed for use exclusively within the values stated on the name plates and within the technical limit values specified on the data sheets.

The following technical limit values must be observed:

- The Maximum Working Pressure may not be exceeded.
- The Maximum ambient operating temperature may not be exceeded.
- The Maximum process temperature may not be exceeded.
- The housing protection type must be observed.

## Warranty prevision

Using the device in a manner that does not fall within the scope of its intended use, disregarding this manual, using underqualified personnel, or making unauthorized alterations, releases the manufacturer from any liability for any resulting damage. This makes the manufacturer's warranty null and void.

## Use of instruction

The symbols used in this document are explained below:

### **DANGER**

The signal word '**DANGER**' indicates an imminent danger. Failure to observe this information will result in death or severe injury.

### **WARNING**

The signal word '**WARNING**' indicates an imminent danger. Failure to observe this information may result in death or severe injury.

### **CAUTION**

The signal word '**CAUTION**' indicates an imminent danger. Failure to observe this information may result in minor or moderate injury.

### **NOTICE**

The signal word '**NOTICE**' indicates potential damage to material or its surrounding area.

### **IMPORTANT**

This message indicates operator tips or particularly useful information. It does not indicate a dangerous or damaging situation.

## Operator liability

Prior to using corrosive and abrasive materials for measurement purposes, the operator must check the level of resistance of all parts coming into contact with the materials to be measured.

ABB will gladly support you in selecting the materials, but cannot accept any liability in doing so.

The operators must strictly observe the applicable national regulations with regard to installation, function tests, repairs, and maintenance of electrical devices.

## Qualified personnel

Installation, commissioning, and maintenance of the device may only be performed by trained specialist personnel who have been authorized by the plant operator. The specialist personnel must have read and understood the manual and comply with its instructions.

## Returning devices

Use the original packaging or suitably secure shipping package if you need to return the device for repair or recalibration purposes. Fill out the return form (see the end of the document) and include this with the device.

According to EC guidelines and other local laws for hazardous materials, the owner of hazardous waste is responsible for its disposal. The owner must observe the proper regulations for shipping purposes.

All devices sent back to ABB must be free from any hazardous materials (acids, alkalis, solvents, etc.).

## Disposal

ABB actively promotes environmental awareness and has an operational management system that meets the requirements of DIN EN ISO 9001:2000, EN ISO 14001:2004, and OHSAS 18001. Our products and solutions are intended to have minimum impact on the environment and persons during manufacturing, storage, transport, use and disposal.

This includes the environmentally friendly use of natural resources. ABB conducts an open dialog with the public through its publications.

This product/solution is manufactured from materials that can be reused by specialist recycling companies.

## Information on WEEE Directive 2012/19/EU

This product or solution is subject to the WEEE Directive 2012/19/EU (Waste Electrical and Electronic Equipment) or corresponding national laws. Starting from August 15th 2018, electrical and electronic equipment marked with the crossed-out wheeled bin symbol may not be disposed as unsorted municipal waste. Waste of electrical and electronic equipment (WEEE) shall be treated separately using the national collection framework available to customers for the return, recycling and treatment of WEEE.

Proper disposal prevents negative effects on people and the environment, and supports the reuse of valuable raw materials. ABB can accept and dispose of returns for a fee.

## Transport and storage

- After unpacking the pressure transmitter, check the device for transport damage.
- Check the packaging material for accessories.
- During intermediate storage or transport, store the pressure transmitter in the original packaging only.

For information on permissible ambient conditions for storage and transport, see "Technical data". Although there is no limit on the duration of storage, the warranty conditions stipulated on the order acknowledgment from the supplier still apply.

To prevent damage affecting the performance of the measurement, care should be given to protect the sensing diaphragm of the remote seal when transporting, installing and performing maintenance on the transmitter.

Special attention should be given to extended diaphragms and front-bonded type seals where the sensing diaphragm is unprotected at the leading edge.

## Safety information for electrical installation

Electrical connections may only be established by authorized specialist personnel in accordance with the electrical circuit diagrams. The electrical connection information in the manual must be observed; otherwise, the applicable protection type may be affected. Ground the measurement system according to requirements.

## Safety information for inspection and maintenance

### WARNING

There is no EMC protection or protection against accidental contact when the housing cover is open. There are electric circuits within the housing which are dangerous if touched. Therefore, the auxiliary power must be switched off before opening the housing cover.

### WARNING

The device can be operated at high pressure and with aggressive media. Any process media released may cause severe injuries. Depressurize the pipeline/tank before opening the transmitter connection.

Corrective maintenance work may only be performed by trained personnel.

- Before removing the device, depressurize it and any adjacent lines or containers.
- Check whether hazardous materials have been used as materials to be measured before opening the device.
- Residual amounts of hazardous substances may still be present in the device and could escape when the device is opened.
- Within the scope of operator responsibility, check the following as part of a regular inspection:
  - Pressure-bearing walls/lining of the pressure device
  - Measurement-related function
  - Leak-tightness
  - Wear (corrosion)

## 4 Overview

### Seal system

The S26 Series Seal System is a protective device used to isolate transmitters from the process fluid.

When used without diaphragm seals, these transmitters are generally connected to process piping or process vessel by impulse lines. The process fluid leaves its enclosure, fills the impulse lines, and enters the body of the transmitter. For certain applications, it is necessary to prevent the process fluid from leaving its enclosure. The seal system provides a flexible diaphragm seal between the process fluid and a liquid filled capillary tube connected to the body of the transmitter. The diaphragm isolates the process fluid while the filled capillary tube hydraulically transmits the process pressure to the transmitter body.

Some reasons why an isolating seal is required are:

- The process fluid is highly corrosive. Remote seals offer a much wider choice of corrosion resistant materials compared to conventional transmitters.
- The process fluid has solids in suspension or is highly viscous and can clog impulse lines.
- The process fluid can solidify in impulse lines or inside the transmitter body.
- The process fluid is too hazardous to enter the control area where the transmitter is located.
- The process temperature exceeds the recommended maximum or minimum limits for the transmitter.
- The application is interface level or density measurement. Remote seals offer the required constant and equal specific gravity of the pressure transfer fluid on the high and low sides of the transmitter.
- The transmitter body must be located away from the process for easier maintenance.

The S26 series is available in a variety of seal element types. They provide process connection to ANSI, JIS or EN pipe flanges, wedge flow elements, chemical tees, and threaded pipe fittings. Extended diaphragm remote seals are suitable for connection to 2-inch, 3-inch or 4-inch flanged tank nozzles or flanged tees permit the seal diaphragm to be located flush with the inside of a tank or pipe. Sanitary and sanitary aseptic type seals meet the stringent requirements of sanitary food, dairy, pharmaceutical, and Biotech applications. All sanitary seals comply with 3A Sanitary Standard No. 74-02. These remote seal systems feature unique all welded construction (see in Figures 31 and 32). This construction assures reliable operation over a wide range of operating temperatures and pressures. It is especially important in preventing air leakages when the system is operating under vacuum conditions.

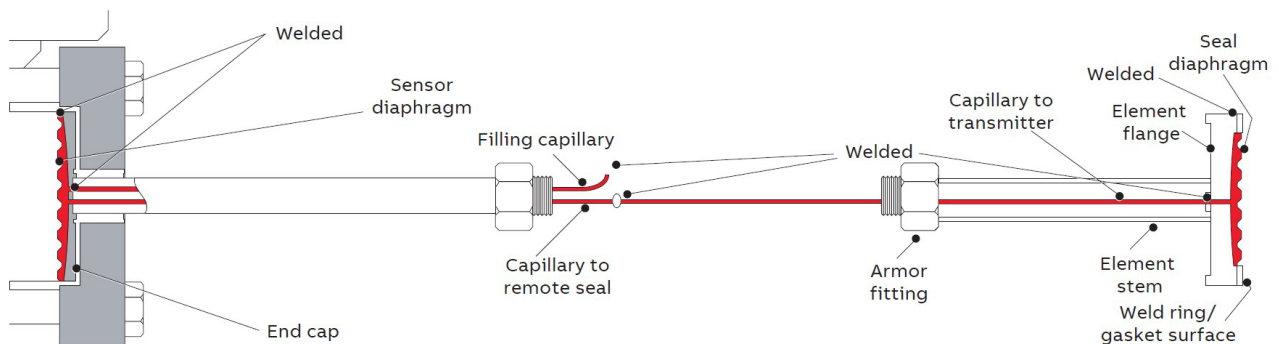

Figure 31: Seal system components

## 5 Opening the box

### Identification

The transmitter and seal system are identified by product code numbers which are stamped on the transmitter nameplate. An example of the product code stamping is as follows:

266DRHGSRRAH / S26WAHD5FSM2AASNNN  
 Transmitter Product Code Seal System Product Code

Refer to ordering information for a detailed explanation of the product code numbers.

### Handling

When handling and/or installing the transmitter with S26 series remote seal(s), please consider that the minimum bending radius of the capillary system is 10 cm (3.9 in). does not require any special precautions during handling although normal good practice should be observed.

## 6 Mounting

### General

The transmitters with remote seals are suitable for use on the following pressure and differential pressure measurement applications:

- FLOW MEASUREMENT
- LIQUID LEVEL MEASUREMENT
- INTERFACE LEVEL MEASUREMENT
- DENSITY MEASUREMENT
- GAUGE PRESSURE MEASUREMENT
- ABSOLUTE PRESSURE MEASUREMENT

Each application has certain unique requirements which influence the selection of the transmitter and seal locations. In general the flow and gauge pressure applications allow the greatest flexibility in selection of a location. Liquid level applications impose restrictions on the relative elevations of the transmitter and seals when the tank operates under vacuum and absolute pressure applications impose similar restrictions when the lower range value is less than atmospheric pressure (nominally 14.7 psia). Transmitters with remote seals measure pressure from two sources: the applied process pressure or differential pressure, and the head pressure developed by the weight of the liquid column in the seal system. The head pressures are a function of transmitter and seal locations as follows:

- Two Seals

On a DP transmitter with a seal on both the high and low sides, the transmitter measures the head pressure resulting from any difference in elevation between the seals and the output change is directly proportional to the elevation difference. The head pressure has no effect on transmitter output when both seals are at the same elevation. Changing the elevation of the seals relative to the transmitter has no effect as long as the elevation of one seal relative to the other is not changed.

- One Seal

On a transmitter with one seal, the head pressure from the seal system is measured directly. Any change in the elevation of the seal causes a change in the measured head pressure and the transmitter output changes in direct proportion to the elevation change.

### IMPORTANT

When handling and/or installing the transmitter with remote seal(s), please consider that the minimum bending radius of the capillary system is 10 cm (3.9 in).

For most flow, gauge pressure, and absolute pressure installations the effect of head pressure is relatively minor and can be canceled out by adjusting zero with the transmitter and seals in their installation position while a known process pressure is applied. For liquid level installations, head pressures have a more significant impact on calibration requirements because the nature of the installation requires a substantial difference in elevation between the high and low side seals. See the Liquid Level Measurement Section for more information.

### Flow measurement

Differential pressure transmitters with two remote seals can be used for both horizontal and vertical flow measurement installations by means of a Wedge Flow Element. In both horizontal and vertical installations, the transmitter can be placed in any convenient location either above or below the elevation of the seal elements. The high side seal element must be located on the upstream side of the flow restriction. To ensure accurate measurements on liquid flow applications, the flow restriction must be located in a section of the pipe line which remains full under all flow conditions.

- Horizontal Installation

In a horizontal installation both seal elements are at the same elevation and head pressures resulting from the filling liquid are equal on the high and low side of the transmitter. Thus, the transmitter calibration can be zero based for this installation. If the process contains suspended solids, the seal elements should be located at the top of the pipe to avoid collection of solid material on the seal diaphragm surfaces.

- Vertical installation

In a vertical installation, the elevation difference between the two seals applies a differential pressure when there is no flow. When the pipe is full at no flow the initial differential is a function of the distance between the seals and the difference in density between the process liquid and the fill liquid.

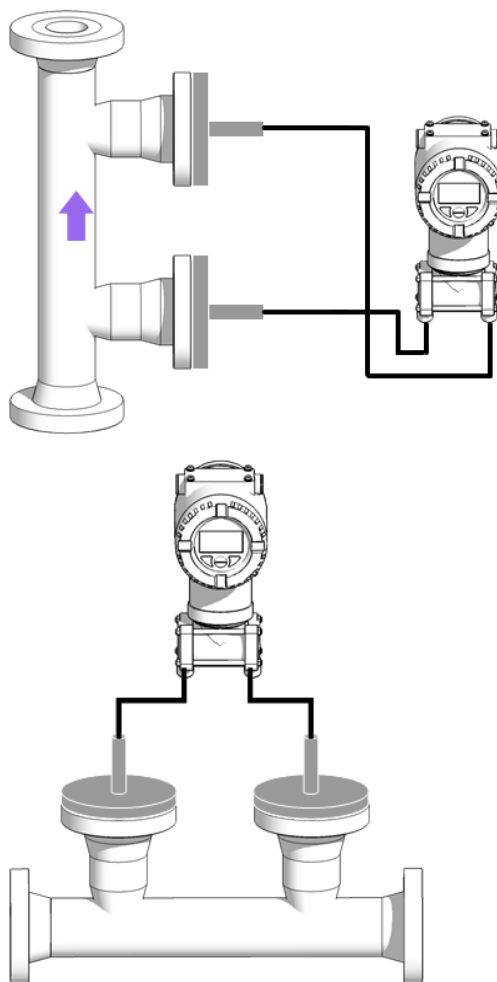

Figure 32: Primary element (Wedge) - vertical and horizontal installations for flow measurements

## Liquid level measurement

A differential pressure transmitter with either one or two remote seals can be used for liquid level measurement on open tanks, closed tanks operating at pressures above atmospheric and closed tanks operating under vacuum.

Liquid level measurements are based on the height of a process liquid column with respect to predefined measurement reference points on the transmitter. The transmitter has three datum lines as follows:

- Primary Datum Line: located at the center of the seal system connection to the transmitter body.
- High Seal Datum Line: located at the center of the high side seal diaphragm.
- Low Seal Datum Line: located at the center of the low side seal diaphragm.

### Open Tank Installation

A transmitter with one remote seal can be used for open tank level measurement.

The seal is on the high side of the transmitter, and the seal element must be located near the bottom of the tank so that the high seal datum line is at or below the minimum level. The transmitter can be located either above or below the seal element. The low side of the transmitter must be vented to atmosphere.

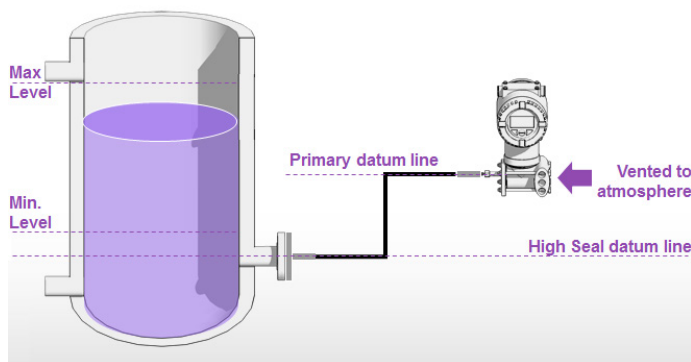

Figure 33: Level measurement of a liquid in an open tank

### Closed Tank Installation – Pressure Service – Double Seal

When a transmitter with two remote seals is used to measure level in a pressurized tank, the high pressure side seal element must be located near the bottom of the tank.

The high seal datum line must be at or below the minimum level. The low side seal must be located near the top of the tank, and the low seal datum line must be at or above the maximum level.

The transmitter can be located between the seals, above both seals or below both seals on a pressure service installation.

The preferred location is mid way between the seal elements. This location minimizes the required capillary length, and usually provides the most uniform distribution of ambient temperatures across the capillary length.

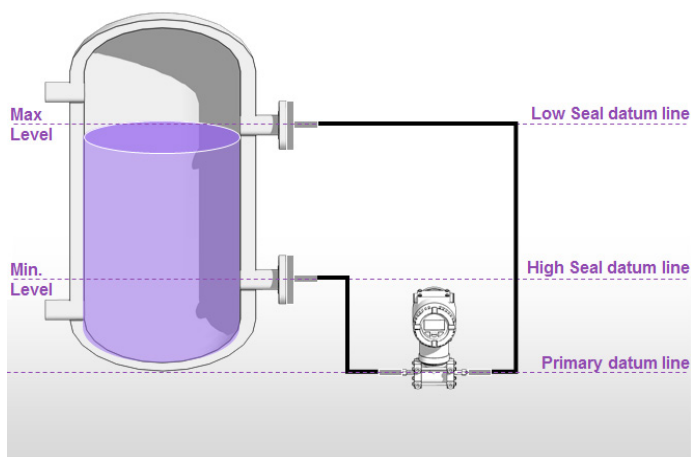

Figure 34: Level measurement of a liquid in a closed tank - vacuum or pressure service

## NOTICE

This installation requires a double-seal transmitter. The transmitter must be installed below the minimum level.

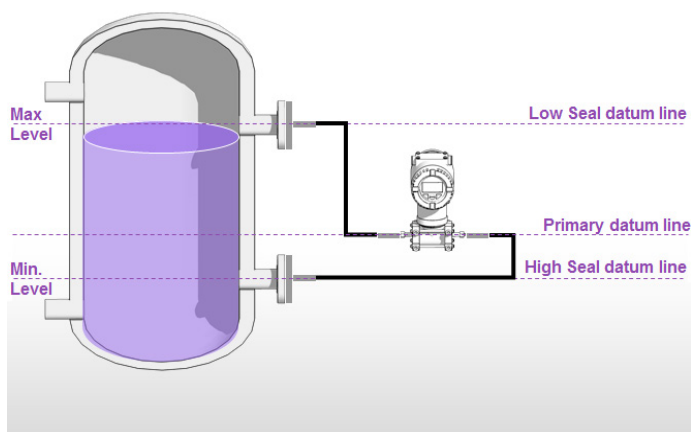

Figure 35: Level measurement of a liquid in a closed tank - pressure service only

## NOTICE

This installation requires a double-seal transmitter. The transmitter must be located between the taps of the tank.

**Closed Tank Installation – Pressure Service – Single Seal**

When a transmitter with one seal is used to measure level in a pressurized tank, a compensating leg must be connected between the vapor space at the top of the tank and the low side of the transmitter.

The remote seal is on the high side of the transmitter, and the seal element must be located near the bottom of the tank so that the high seal datum line is at or below the minimum level. If the process vapor is not readily condensable, or if the compensating leg is at a higher temperature than the tank interior, a dry leg can be used. A trap installed at the bottom of the leg minimizes the possibility of condensate collecting in the transmitter body.

When the process vapor is condensable, a wet leg is recommended. The wet leg is filled with a suitable liquid to maintain a constant pressure on the low side of the transmitter. This approach avoids the problem of process vapor condensing and collecting in the compensating leg resulting in serious measurement error. The leg can be filled with process liquid or any liquid with a low vapor pressure relative to the process. A filling tee is required at the top of the leg. The wet leg can be avoided if the transmitter can be located near the top of the tank, so that condensate drains back into the tank.

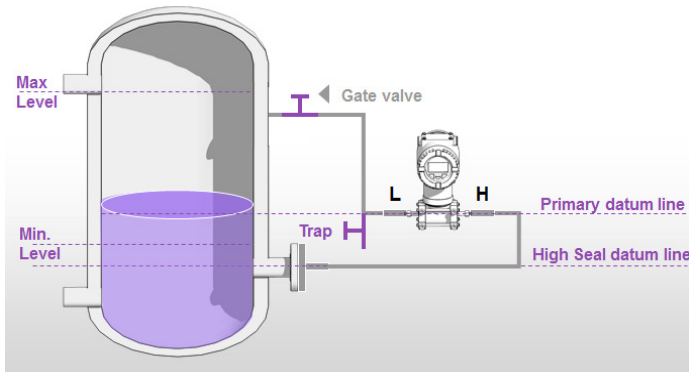

Figure 36: Level measurement of a liquid in a closed tank - pressure service only - condensate trap as option

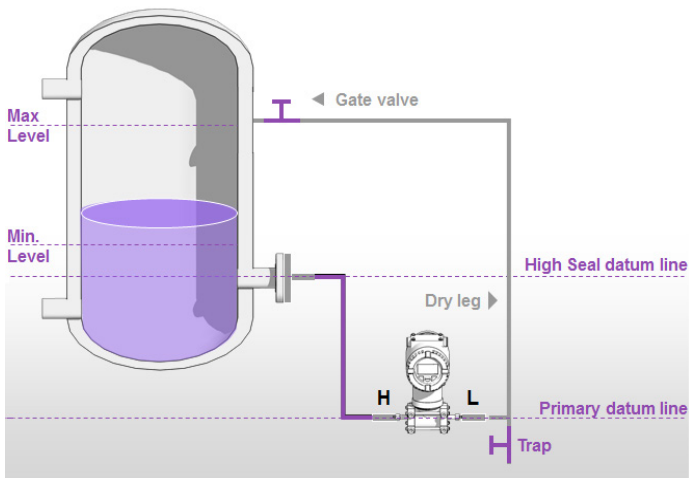

Figure 37: Level measurement of a liquid in a closed tank - vacuum or pressure service - dry leg

**Closed Tank Installation – Vacuum Service**

When the transmitter is used on a tank in which the operating pressure range includes pressures below atmospheric, it is essential that the transmitter be located below the high-pressure seal datum line.

The recommended minimum distance between the primary datum line and the high seal datum line is 1ft (0.3m). Seal element location requirements for vacuum service are the same as for pressure service.

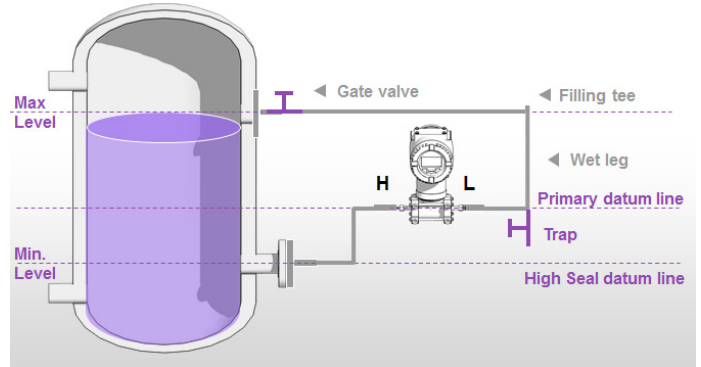

Figure 38: Level measurement of a liquid in a closed tank - pressure service only - wet leg installation

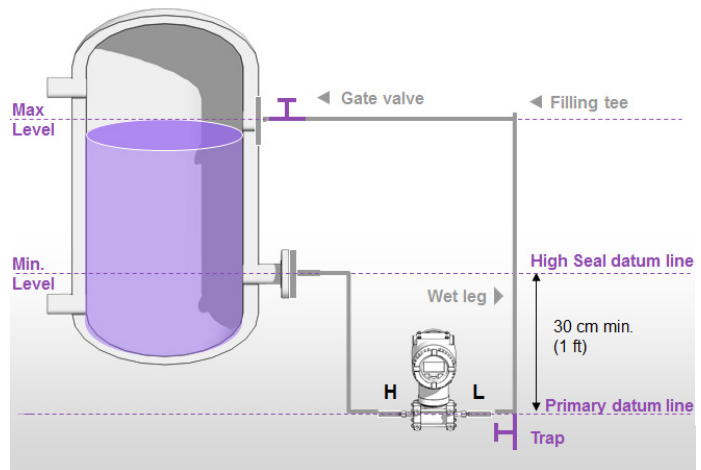

Figure 39: Level measurement of a liquid in a closed tank - vacuum or pressure service - wet leg installation

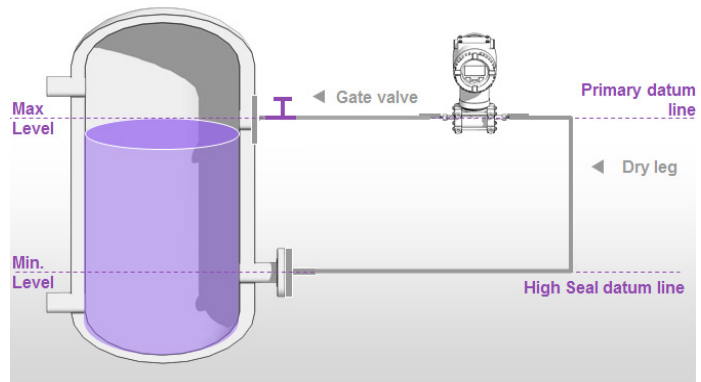

Figure 40: Level measurement of a liquid in a closed tank - vacuum or pressure service - dry leg installation



### Calibration Requirements

The location of the high side seal near the bottom of the tank and the low seal near the top of the tank provides increasing transmitter output for increasing liquid level. The actual differential pressure applied to the transmitter is up to maximum value only when the process is at its minimum level due to the elevation difference between the seals. As the tank fills, the process liquid tends to cancel the initial seal system head pressure and the measured differential pressure is therefore at the minimum value when the level reaches its maximum value.

Note also that the maximum differential is applied from the low side because the low seal has the higher elevation.

To accommodate the head pressure conditions imposed by a liquid level installation, the transmitter zero must be adjusted to elevate the output. This cancels the effect of the low side head pressure and provides zero percent output for the minimum level condition. For example, the range values for a level installation might be -120 to -5 inches of water. This indicates that the level change (span) is 115 inches of water; the differential at minimum level is -120 and at maximum level is -5 inches of water.

The minus sign indicates positive differential pressures applied to the low side of the transmitter.

Determination of the span and range values for a specific installation must take into account the level change, elevation difference between the seals, height of the process liquid above the high seal datum line at minimum level, and the specific gravity of the process liquid and the fill liquid in the seal system.

### Interface level measurement

A differential pressure transmitter with two remote seals can be used to measure interface level. The high side seal element must be located near the bottom of the tank. The high seal datum line must be at or below the lowest interface elevation. The low side seal must be located near the top of the tank, and the low seal datum line must be at or above the highest interface elevation. The minimum level of liquid in the tank must be above the low seal element under all interface conditions. The transmitter can be located between the seals, above both seals or below both seals when the tank is open or operating under positive pressure. The preferred location for 266 transmitter is directly mounted on the bottom connection. This location enables the user to eliminate the capillary and consequently allows a more accurate measurement. If the operating pressure range includes pressures below atmospheric, the transmitter must be located below the high side seal (refer to the vacuum service information in Liquid Level Measurement Section).

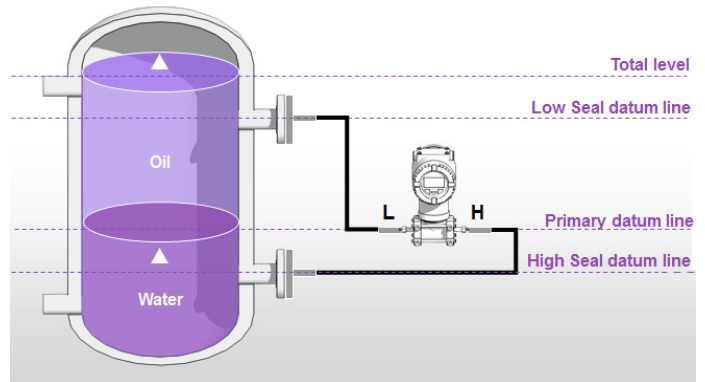

Figure 41: Interface level measurement

### NOTICE

Total liquid level must always be above the top transmitter tap. Both the densities must be predetermined and should remain constant for accurate measurement.

### Density measurement

A differential pressure transmitter with two remote seals can be used to measure liquid density or specific gravity. The high side seal element must be located near the bottom of the tank, and the low side seal must be located near the top of the tank. The minimum level of liquid in the tank must be above the low seal element under all density conditions. The transmitter can be located between the seals, above both seals or below both seals when the tank is open or operating under positive pressure. The preferred location is mid way between the seal elements. This location minimizes the required capillary length, and usually provides the most uniform distribution of ambient temperatures across the capillary length. If the operating pressure range includes pressures below atmospheric, the transmitter must be located below the high side seal (refer to the vacuum service information in Liquid Level Measurement Section).

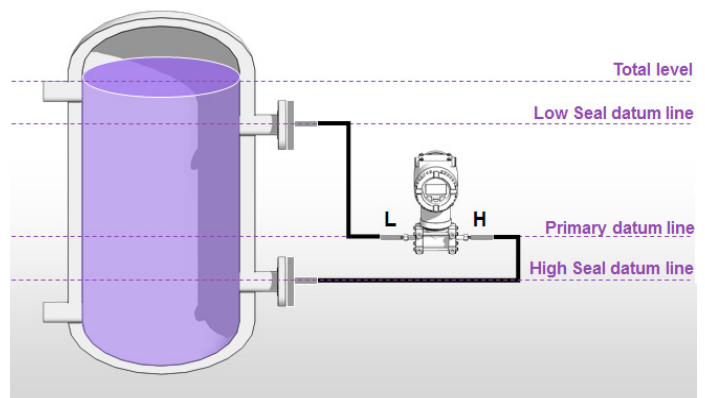

Figure 42: Density or specific gravity measurement

### NOTICE

For this kind of measurement, it is essential to minimize the required capillary length as well as grant a uniform distribution of the ambient temperature.

## Gauge pressure measurement

A gauge pressure transmitter with a remote seal can be used for measurement of pressure in either a process pipe or tank. Locate the remote seal in the side or top of the pipe to avoid collection of sediment on the seal diaphragm.

- **Pressure Service**

When the operating pressure range has a minimum value above atmospheric pressure (0 psig), the transmitter can be placed in any convenient location, either at the same elevation as the remote seal, above the seal, or below the seal.

- **Vacuum Service**

When the operating process pressure range includes pressures below atmospheric, it is essential that the transmitter be located below the elevation of the seal element to ensure that the pressure in the transmitter body is always greater than 0 psia. The recommended minimum distance between the transmitter datum line and the seal datum line is 30cm (1ft).

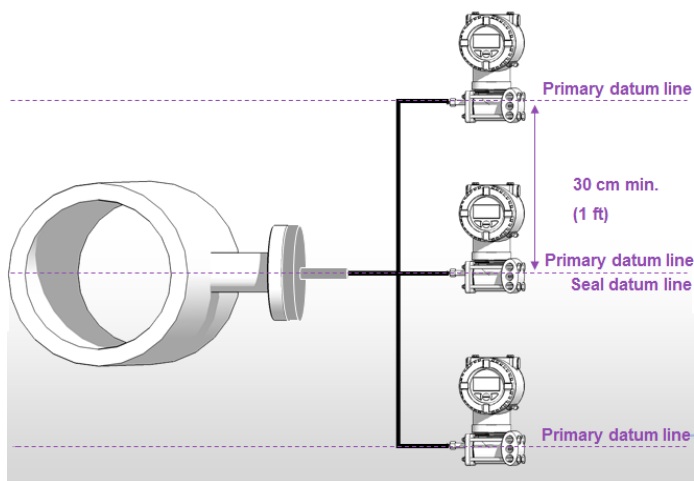

Figure 43: Possible installation for gauge and absolute pressure measurement

### NOTICE

The minimum value is to be above the atmospheric pressure (0 psig). Transmitter can be placed in any convenient location.

## Absolute pressure measurement

An absolute pressure transmitter with a remote seal can be used for measurement of absolute pressure in either a process pipe or tank. Locate the seal element in the side or top of the pipe to avoid collection of sediment on the seal diaphragm. When the operating absolute pressure range has a minimum value above atmospheric pressure (nominally 14.7 psia), the transmitter can be placed in any convenient location, either at the same elevation as the remote seal, above the seal, or below the seal. When the pressure range includes pressures below atmospheric, the transmitter datum line must be below the elevation of the seal element to ensure that the pressure in the transmitter body is always greater than 0 psia. The recommended minimum distance between the transmitter datum line and the seal datum line is 30 cm (1ft).

## Mounting a diaphragm-seal(s)-equipped transmitter

The transmitter with remote seals can be mounted on a 60 mm (2 in.) horizontal or vertical pipe using the optional pipe mounting bracket available with all 2600T and P-Series transmitters. Direct-mount seal transmitters, instead, can be installed without the bracket kit since a mating flange is generally provided.



## 7 Connecting low side compensation leg

Differential pressure transmitters with a single remote seal element are used for liquid level installations. The seal element is connected using the procedure applicable to the type of seal element. The connection requirements for the low side depends on whether the tank is open to atmosphere or closed (pressurized or evacuated). Make the low side connection as described below.

### Open Tank Installation

The low side of the transmitter must be vented to atmosphere for open tank installations. Be sure there are no plastic shipping plugs or other restrictions in the low side flange ports. Connect the seal element using the procedure applicable to the element type. Refer to the Connecting the Remote Seals section.

### Closed Tank Installation

Before connecting the seal element to the tank fitting, determine whether a wet or dry compensating leg is required on the low side of the transmitter. Refer to the Locating the Transmitter and Remote Seals section.

The transmitter is shipped with the vent/drain plug located near the top of the low side flange. In this position the valve permits venting of entrapped gas (normally air) when a wet (liquid filled) compensating leg is required. If a dry leg is required, remove the bolts and rotate the low-side flange 180° so that the vent/drain screw is positioned at the bottom of the flange to permit draining of condensate from the primary cavity. Re-tighten the bolts to a torque of 20 ft-lb.

After properly locating the vent/drain screw, connect the low side to the compensating leg, and connect the seal element using the procedure applicable to the element type. Refer to the Connecting the Remote Seals section.

---

## **ABB Measurement & Analytics**

For your local ABB contact, visit:  
**[abb.com/contacts](https://abb.com/contacts)**

For more product information, visit:  
**[abb.com/measurement](https://abb.com/measurement)**

---

We reserve the right to make technical changes or modify the contents of this document without prior notice. With regard to purchase orders, the agreed particulars shall prevail. ABB does not accept any responsibility whatsoever for potential errors or possible lack of information in this document.

We reserve all rights in this document and in the subject matter and illustrations contained therein. Any reproduction, disclosure to third parties or utilization of its contents – in whole or in parts – is forbidden without prior written consent of ABB.