

PitoMaster FPD550

Compact averaging pitot flowmeter



Introduction

The PitoMaster FPD550 flowmeter is a compact averaging pitot flowmeter designed for the measurement of liquids, gases and steam in pipelines of DN100 to DN600 (4 in. to 24 in.). The meter combines an averaging pitot sensor with an integral isolating/equalizing manifold and transmitter in a single, leak tested and configured assembly. PitoMaster is available for either threaded and flanged insertion pipe connections.

This User Guide provides installation, connection, start-up and basic setup details for the system, with emphasis on the flow sensor. IOMaster is available with either a 364DS or 266DSH DP transmitter or a 267CS multivariable transmitter.

This User Guide should be used in conjunction with the following publications:

364DS DP transmitter:
User Guide – IM/364

266DSH DP transmitter:
User Guide – SOI-266-XC-D
User Guide HART– OI/266/HART-EN
User Guide Foundation Fieldbus – OI/266/FF-EN
Foundation Fieldbus Additional Instructions –
OI/266/FF/ADD-EN
User Guide Profibus PA – OI/266PA-EN

267CS Multivariable transmitter:
User Guide – IM/267C/269C
Communication Description-Profibus –
PA/DP – 41/15-110-EN_03
Communication Description-Foundation Fieldbus –
PA/DP – M/265/7/9/ADD/FF-EN_01
Communication Description-Modbus – 42/15-727-EN

The Company

We are an established world force in the design and manufacture of measurement products for industrial process control, flow measurement, gas and liquid analysis and environmental applications.

As a part of ABB, a world leader in process automation technology, we offer customers application expertise, service and support worldwide.

We are committed to teamwork, high quality manufacturing, advanced technology and unrivalled service and support.

The quality, accuracy and performance of the Company's products result from over 100 years experience, combined with a continuous program of innovative design and development to incorporate the latest technology.

Contents

1 Safety	2	4 Commissioning	17
1.1 Health & Safety	2	4.1 Gas and Liquid Service	17
1.2 Electrical Safety – CEI / IEC 61010-1:2001-2	2	4.2 Steam Service	17
1.3 Symbols – CEI / IEC 61010-1:2001-2	2	5 Operation and Maintenance	18
1.4 Pressure Equipment Safety	3	5.1 Troubleshooting	18
1.5 User Guidelines	3	5.2 PitoMaster Removing	19
1.6 Permissible Process Media (Fluids)	3	5.2.1 Removing Threaded Process Connection ..	19
1.7 Technical Limit Values	3	5.2.2 Removing Flanged Process Connection	19
1.8 Safety Precautions	3	5.3 Examination	19
1.9 Health and Safety Information	4	5.4 PitoMaster Refitting	20
1.10 Potential Safety Hazards	4	5.4.1 Refitting Threaded Process Connection	20
2 Initial Installation	5	5.4.2 Refitting Flanged Process Connection	20
2.1 General	5	5.5 Remotely Mounted RTD Replacement	20
2.1.1 Upstream Straight Pipe Requirements	5	6 Specification – General	21
2.1.2 Weights	6	Notes	24
2.1.3 Dimensions	7		
2.2 Mounting	11		
2.2.1 General	11		
2.2.2 Horizontal Pipe Mounting – Gas	12		
2.2.3 Horizontal Pipe Mounting – Liquids	12		
2.2.4 Horizontal Pipe Mounting – Steam	12		
2.2.5 Vertical Pipe Mounting – All Applications	12		
2.3 Mechanical Installation	13		
2.3.1 Threaded Process Connection	13		
2.3.2 Threaded Process Connection with End Support	13		
2.3.3 Flanged Process Connection	14		
2.3.4 Flanged Process Connection with End Support	14		
2.4 Flanged Pipe Fitting (Stand-Off) Installation	15		
2.5 Remote RTD Installation	16		
3 Configuration	16		

1 Safety

Information in this manual is intended only to assist our customers in the efficient operation of our equipment. Use of this manual for any other purpose is specifically prohibited and its contents are not to be reproduced in full or part without prior approval of the Technical Publications Department.

1.1 Health & Safety

Health and Safety

To ensure that our products are safe and without risk to health, the following points must be noted:

- The relevant sections of these instructions must be read carefully before proceeding.
- Warning labels on containers and packages must be observed.
- Installation, operation, maintenance and servicing must only be carried out by suitably trained personnel and in accordance with the information given.
- Normal safety precautions must be taken to avoid the possibility of an accident occurring when operating in conditions of high pressure and / or temperature.
- Chemicals must be stored away from heat, protected from temperature extremes and powders kept dry. Normal safe handling procedures must be used.
- When disposing of chemicals ensure that no two chemicals are mixed.

Safety advice concerning the use of the equipment described in this manual or any relevant Material Safety Data Sheets (where applicable) may be obtained from the Company address on the back cover, together with servicing and spares information.



1.2 Electrical Safety – CEI / IEC 61010-1:2001-2













This equipment complies with the requirements of CEI / IEC 61010-1:2001-2 'Safety Requirements for Electrical Equipment for Measurement, Control and Laboratory Use' and complies with US NEC 500, NIST and OSHA.

If the equipment is used in a manner NOT specified by the Company, the protection provided by the equipment may be impaired.

1.3 Symbols – CEI / IEC 61010-1:2001-2

One or more of the following symbols may appear on the equipment labelling:

	Protective earth (ground) terminal.
	Functional earth (ground) terminal.

	Direct current supply only.
	Alternating current supply only.
	Both direct and alternating current supply.
	The equipment is protected through double insulation.
	This symbol, when noted on a product, indicates a potential hazard which could cause serious personal injury and / or death. The user should reference this instruction manual for operation and / or safety information.
	This symbol, when noted on a product enclosure or barrier, indicates that a risk of electrical shock and / or electrocution exists and indicates that only individuals qualified to work with hazardous voltages should open the enclosure or remove the barrier.
	This symbol indicates that the marked item can be hot and should not be touched without care.
	This symbol indicates the presence of devices sensitive to electrostatic discharge and indicates that care must be taken to prevent damage to them.
	This symbol identifies a risk of chemical harm and indicates that only individuals qualified and trained to work with chemicals should handle chemicals or perform maintenance on chemical delivery systems associated with the equipment.
	This symbol indicates the need for protective eye wear.
	This symbol indicates the need for protective hand wear.
	Electrical equipment marked with this symbol may not be disposed of in European public disposal systems. In conformity with European local and national regulations, European electrical equipment users must now return old or end-of-life equipment to the manufacturer for disposal at no charge to the user.
	Products marked with this symbol indicates that the product contains toxic or hazardous substances or elements. The number inside the symbol indicates the environmental protection use period in years.

1.4 Pressure Equipment Safety

Warning.

- The Pressure Equipment described in this manual is supplied, where appropriate, in accordance with the European Directive 97/23/EC and is designed to work in pressurized systems. Take care when installing all equipment and follow the instructions given. Failure to do this could result in damage to equipment and create possible hazards to operators and other equipment. Only use the equipment on the process for which it is designed. Install the equipment into a system that has been designed to allow for venting or draining of the process. For the necessary safety requirements refer to the appropriate instructions in this manual.
- Do not exceed the pipe vibration levels stated in the Specification (see Section 6, page 21). Excessive vibration could result in damage to the equipment and create possible hazards to other equipment and operators.

1.5 User Guidelines

Correct use includes the following:

- Operation within the technical limit values.
- Observing and following the information provided on permissible media (fluids).
- Observing and following the instructions provided in the operating manuals.
- The following uses are not permitted:
 - Operation as a flexible adaptor in piping; for example, to compensate for pipe offsets, pipe vibrations and/or pipe expansions.
 - Use as a climbing aid; for example, for assembly purposes.
 - Use as a support for external loads; for example, as a support for piping.
 - Material gain; for example, by painting over the type plate or welding or soldering on parts.
 - Repairs, modifications, supplements or the installation of spare parts. These are permitted only if performed as described in the operating manual. More extensive work must be approved by ABB – the Company accepts no liability for unauthorized work.

The operating, maintenance and repair conditions that are stated in this manual must be observed. The Company accepts no liability for damage caused by usage that is incorrect or unprofessional.

1.6 Permissible Process Media (Fluids)

Process media may be used only if:

- It can be assured that the physical and chemical properties of the pressure-bearing materials that come into contact with the process medium are not reduced from that required for operational safety, during the expected lifetime of the equipment.
- Process media with unknown properties for erosion and/or corrosion may be used only if the operator can perform regular and suitable tests to assure the safe condition of the equipment.

1.7 Technical Limit Values

The equipment is intended for use only within the technical limit values specified on the data plate and in the Specification (see Section 6, page 21), including those for:

- The maximum working pressure.
- The maximum and minimum operating temperatures.
- The maximum vibration level stated in the Specification – see Section 6, page 21.

In addition, all connected pipework must be installed as it was designed, to ensure that there is no possibility of leakage or any undue stresses or strain acting upon it.

1.8 Safety Precautions

Instructions and procedures in this manual may require special precautions to ensure the safety of personnel performing the operations. Explosions could result in death or serious injury; therefore refer to the **Warnings** in the transmitter Operating Instructions (Transmitter operating manuals IM/364 Rev. 2 [V Design Level 1] SOI-266-XC-D-05-2011 [V Design Level 2] IM/267C/269C Rev. A [M Design Level 1]) before performing any operation in this manual.

1.9 Health and Safety Information

PitoMaster is supplied specifically for the application detailed on the tag-plate attached by a ring to the head of the product. Before installing PitoMaster, ensure the tag-plate information is correct for that application and matches the required specification. **Do not** use PitoMaster for any other application without consulting ABB Limited or an accredited agent.

The instructions in this document detail the important basic information to ensure correct installation. However, it is the user's responsibility to ensure that suitably qualified personnel perform the installation to established and recognized engineering codes of practice.

Warnings in this document and warning labels on both the PitoMaster and its containers/packaging must be observed.

Warning.

- Before drilling into a process pipe, or before carrying out any maintenance activity or component replacement, reduce the pipe pressure to a safe level and remove all potentially injurious process material.

Ensure the process material does not exceed the pressure and temperature limits of the PitoMaster as specified.

- The part of the PitoMaster external to the process pipe may present a burn hazard, especially if the maximum temperature of the process material exceeds 100 °C (212 °F). Either lag or shield the exposed parts of the PitoMaster to protect personnel or display clear warning signs to alert personnel to the possible hazard. Refer to Standard EN563: 1904 'Safety of Machinery – Temperatures of Touchable Surfaces'.

It is the customer's responsibility to ensure the products detailed in this publication are not used for purposes other than those for which they are designed.

Any modification to or adaptation of PitoMaster may invalidate its certification.

It is the user's responsibility to ensure that adequate protection exists to prevent pressurization in excess of the maximum specified pressure for PitoMaster, even in the event of a fire.

If there are any queries regarding the instructions in this publication, contact either ABB Limited or their accredited agent before installing PitoMaster.

1.10 Potential Safety Hazards

The following potential safety hazards are associated with operating the system:

- Electrical (line voltage)
- Product (FPD550) weight

2 Initial Installation

2.1 General

2.1.1 Upstream Straight Pipe Requirements

To meet specified accuracy figures, install PitoMaster at distances of **no less** than those shown in Fig. 2.1 from flow disturbances in the pipe. If PitoMaster is installed within distances less than those shown, absolute accuracy will decrease BUT repeatability of measurement will continue to be excellent due to the inherent averaging characteristics. If it is not possible to comply with this instruction and maximum accuracy is required, or for other piping configurations, consult ABB.

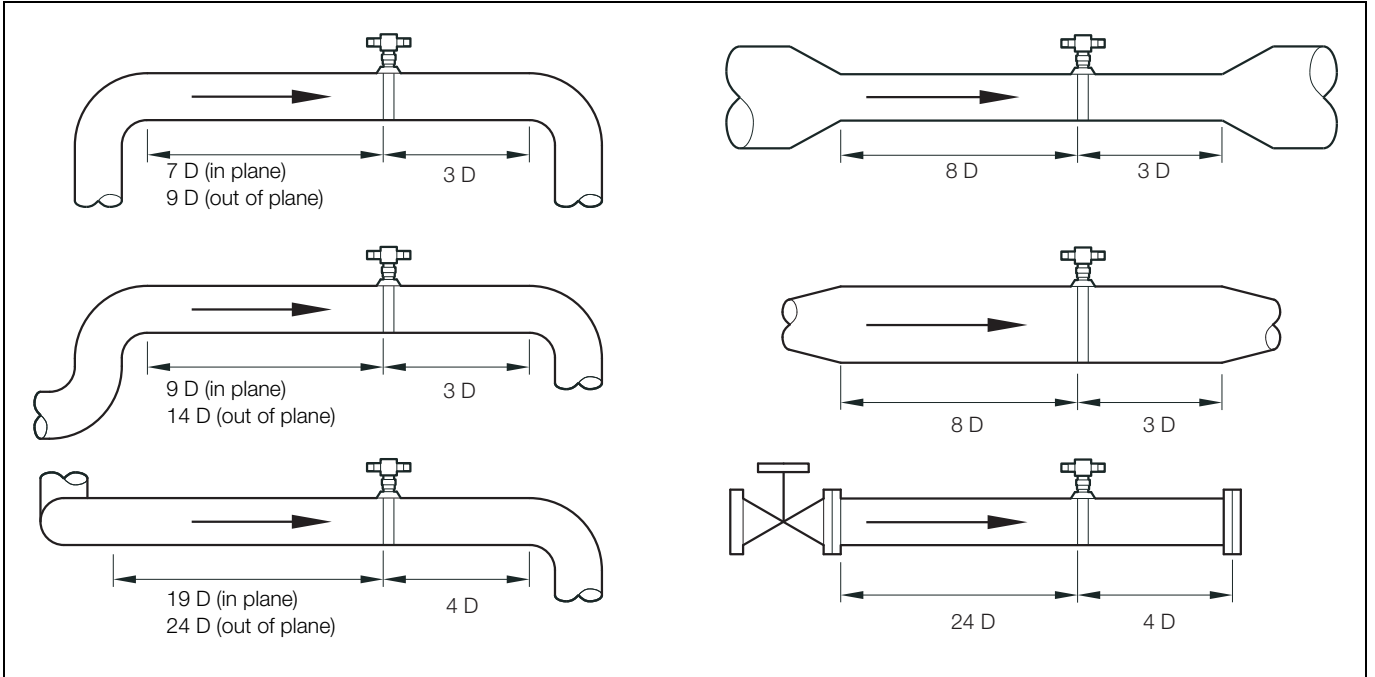

Fig. 2.1 Straight Pipe Requirements

2.1.2 Weights

Size mm (in.)	Threaded	Flanged 1½ in. ANSI 150lb	Flanged 1½ in. ANSI 300lb	Flanged DN40 PN10/16	Flanged DN40 PN25
100 (4)	10 (22)	12 (26.5)	13 (28.7)	12 (26.5)	12 (26.5)
150 (6)	10 (22)	12 (26.5)	13 (28.7)	13 (28.7)	13 (28.7)
200 (8)	10 (22)	12 (26.5)	13 (28.7)	13 (28.7)	13 (28.7)
250 (10)	11 (24.3)	12 (26.5)	14 (30.9)	13 (28.7)	13 (28.7)
300 (12)	11 (24.3)	12 (26.5)	14 (30.9)	13 (28.7)	13 (28.7)
350 (14)	11 (24.3)	12 (26.5)	14 (30.9)	13 (28.7)	13 (28.7)
400 (16)	11 (24.3)	12 (26.5)	14 (30.9)	13 (28.7)	13 (28.7)
450 (18)	11 (24.3)	13 (28.7)	14 (30.9)	13 (28.7)	13 (28.7)
500 (20)	11 (24.3)	13 (28.7)	14 (30.9)	13 (28.7)	13 (28.7)
600 (24)	11 (24.3)	13 (28.7)	14 (30.9)	13 (28.7)	13 (28.7)

Weight adders:
5-valve manifold +1 kg
PitoMaster V design level 2 (SS) +2 kg (4.4 lb)
PitoMaster M design level 1 (SS) +1 kg (2.2 lb)

Table 2.1 Approximate Weights (Excluding Pipe Fittings / End Supports)

2.1.3 Dimensions

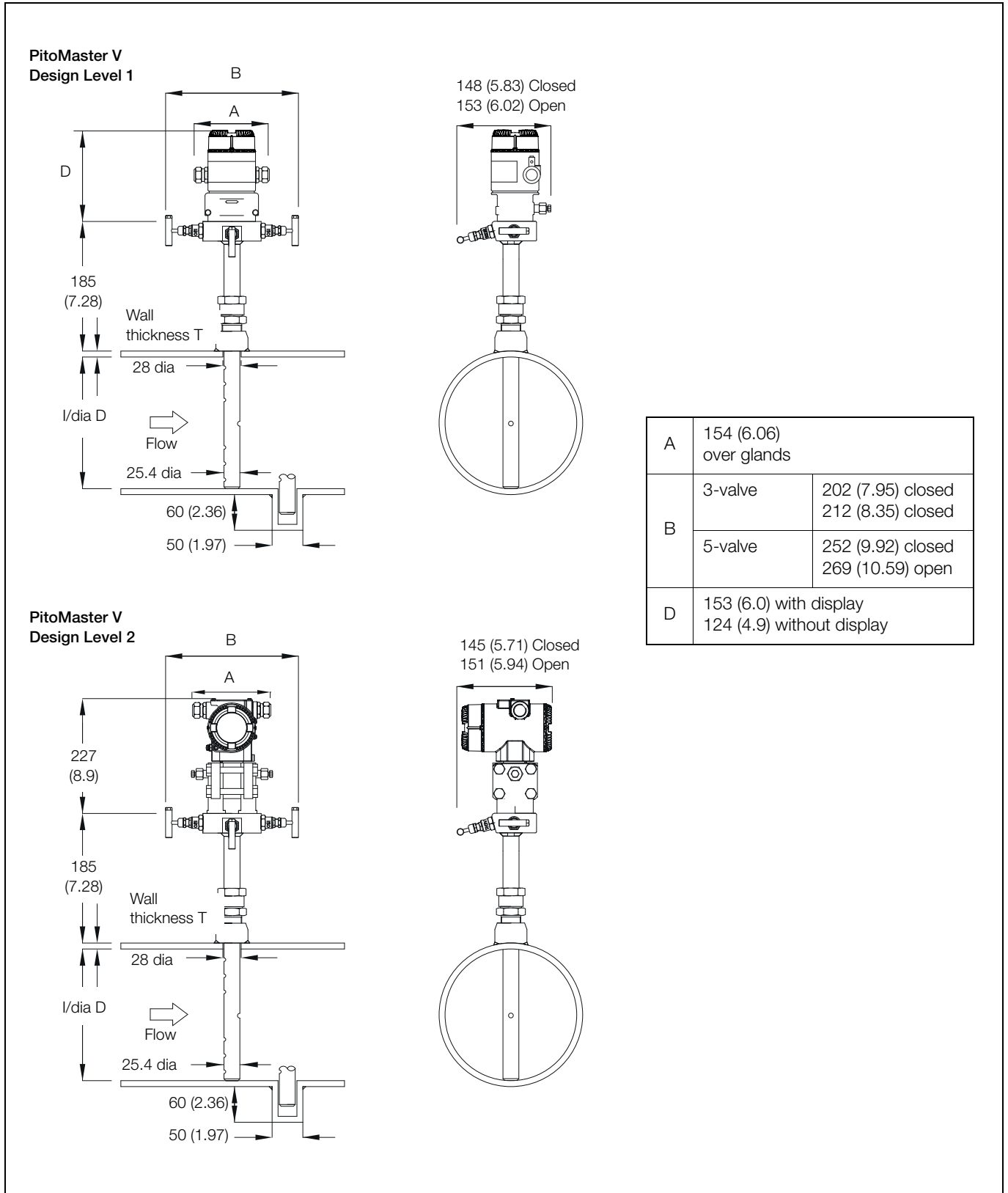

Fig. 2.2 FPD550 PitoMaster V Dimensions, Threaded Process Connections

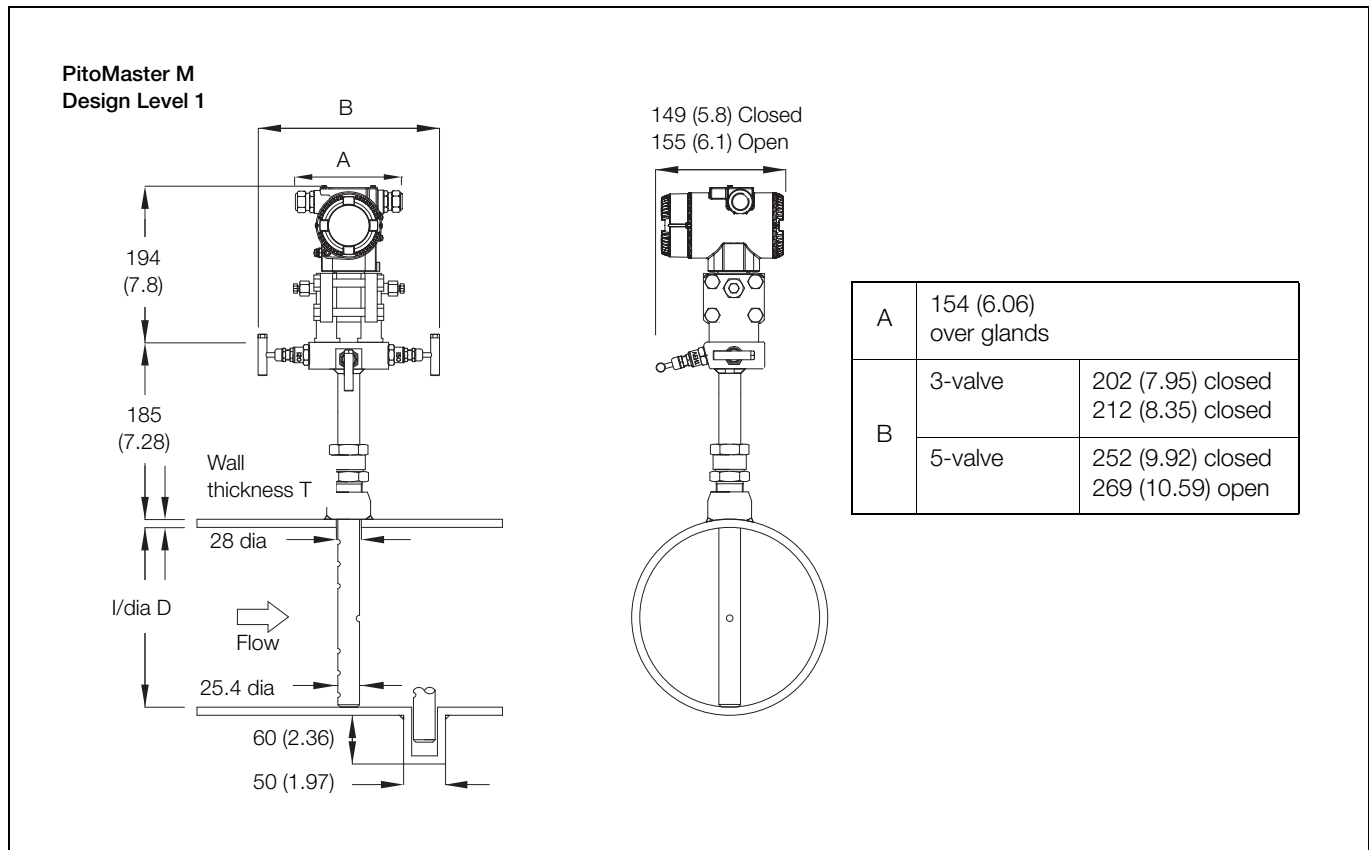

Fig. 2.3 FPD550 PitoMaster M Dimensions, Threaded Process Connection

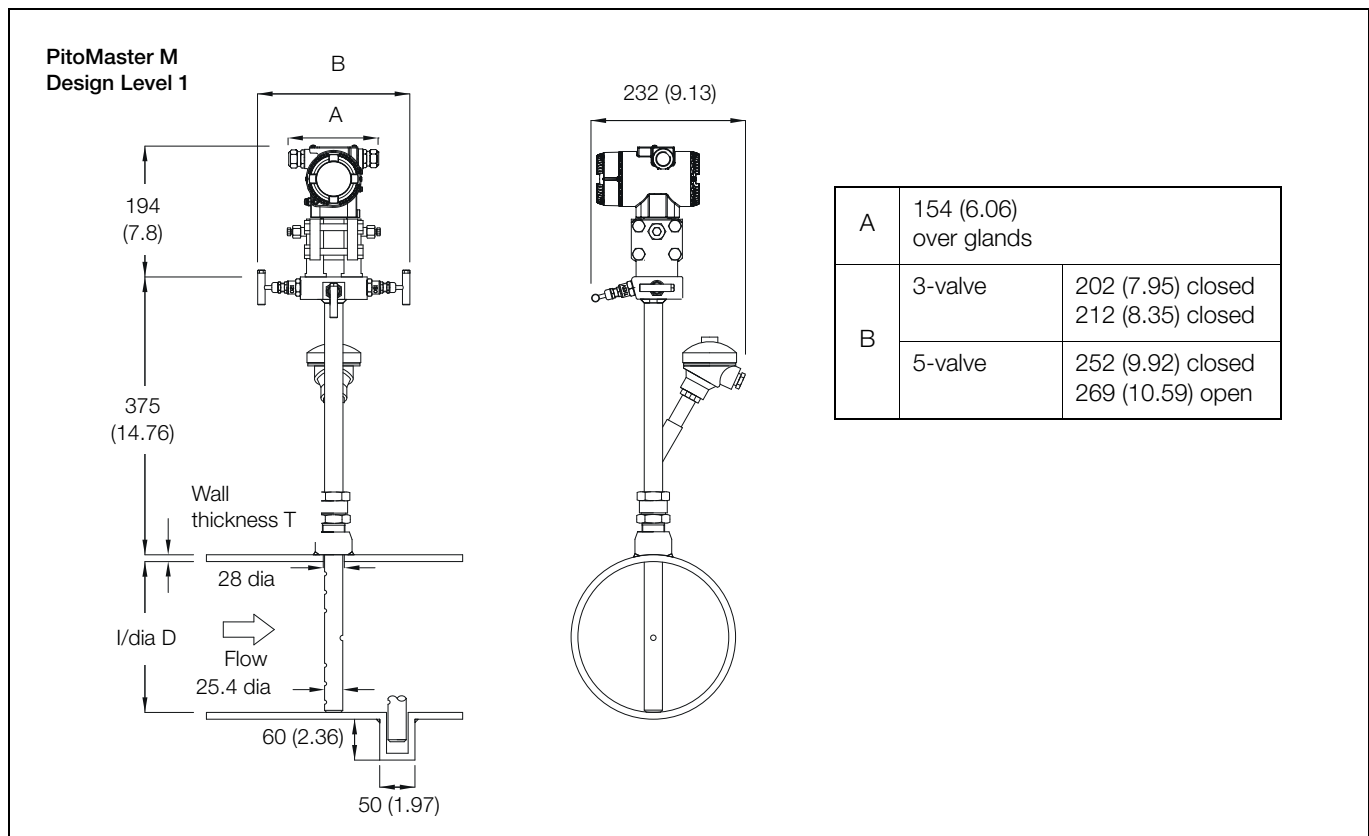

Fig. 2.4 FPD550 PitoMaster M Dimensions, Threaded Process Connection and Internal Temperature Measurement

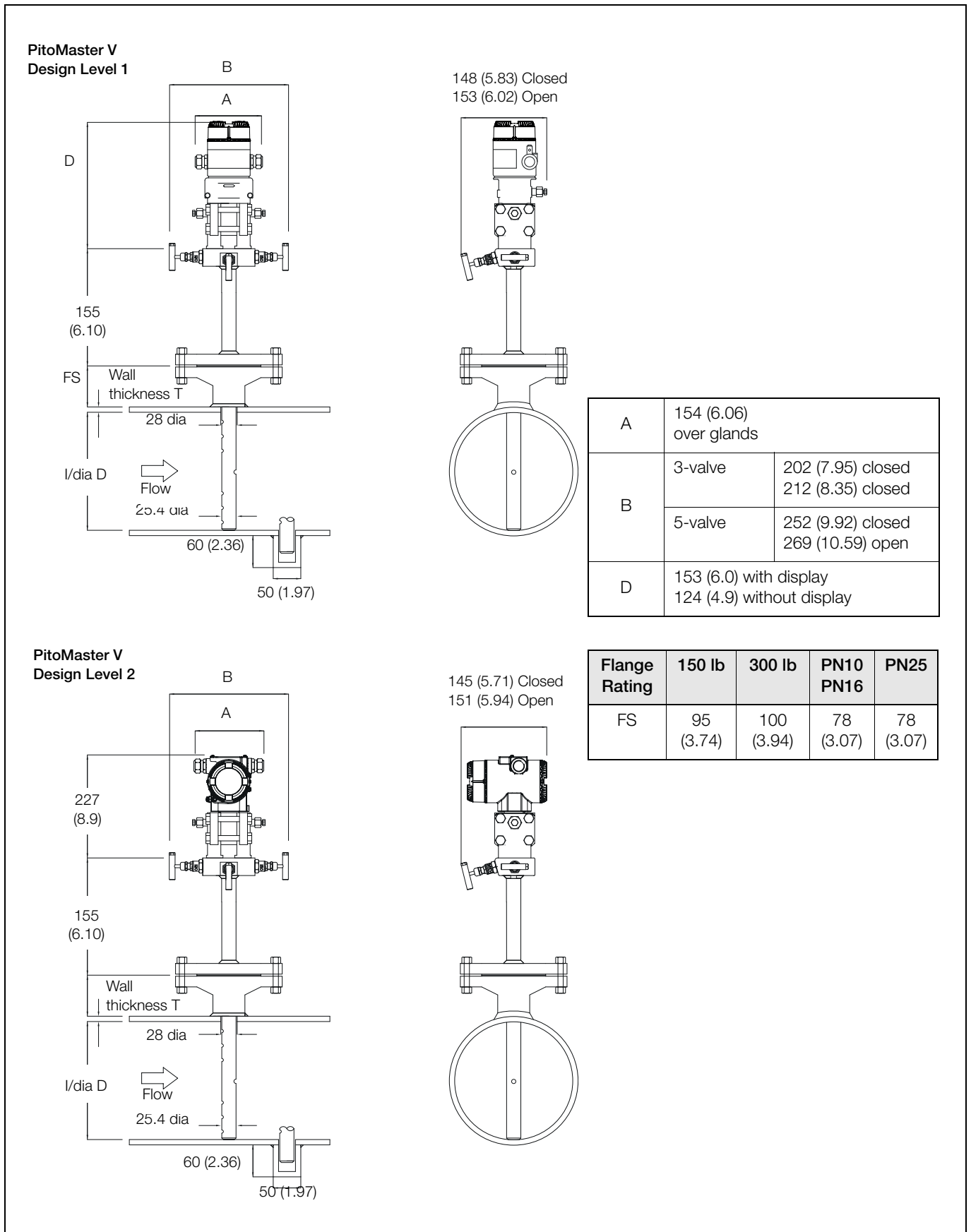

Fig. 2.5 FPD550 PitoMaster V Dimensions, Flanged Process Connection

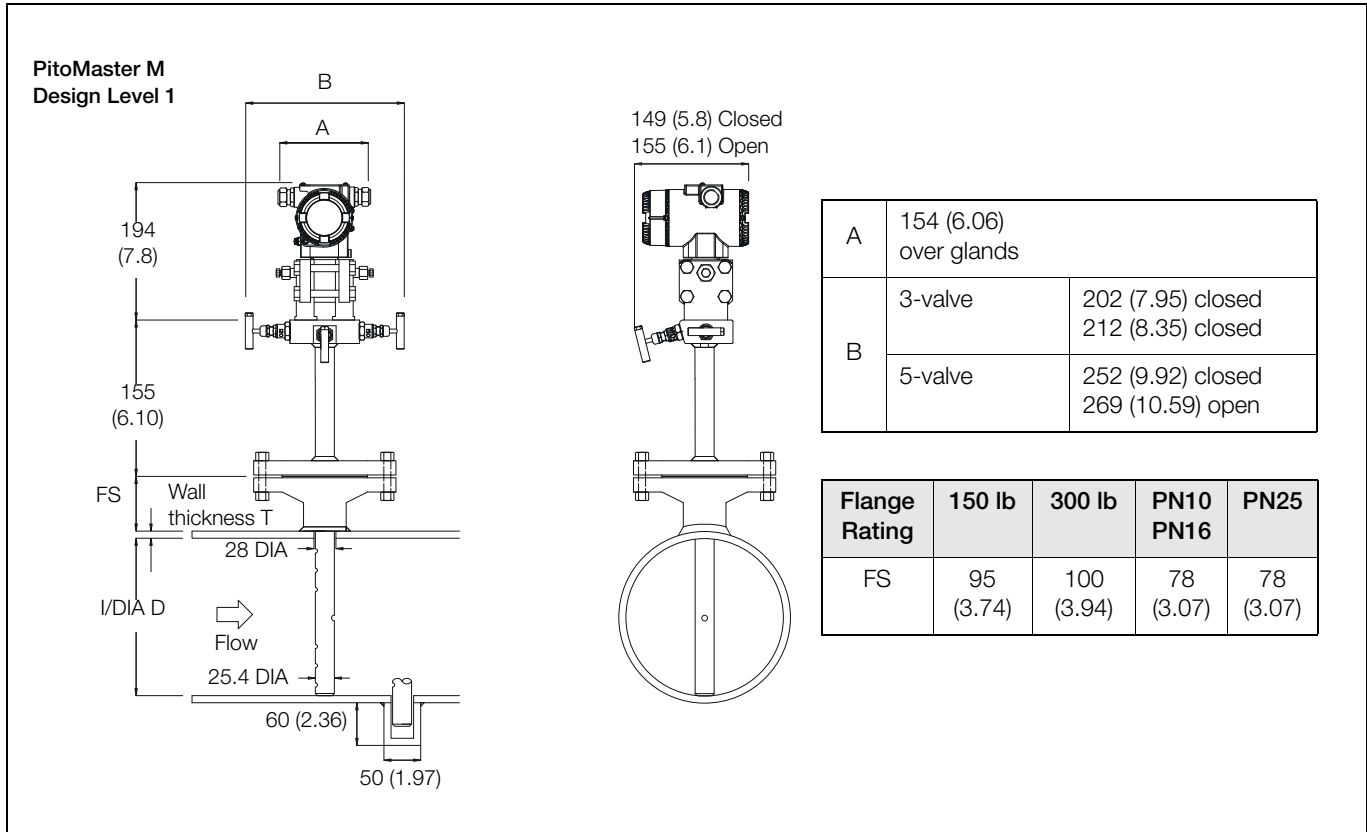

Fig. 2.6 FPD550 PitoMaster M Dimensions, Flanged Process Connection

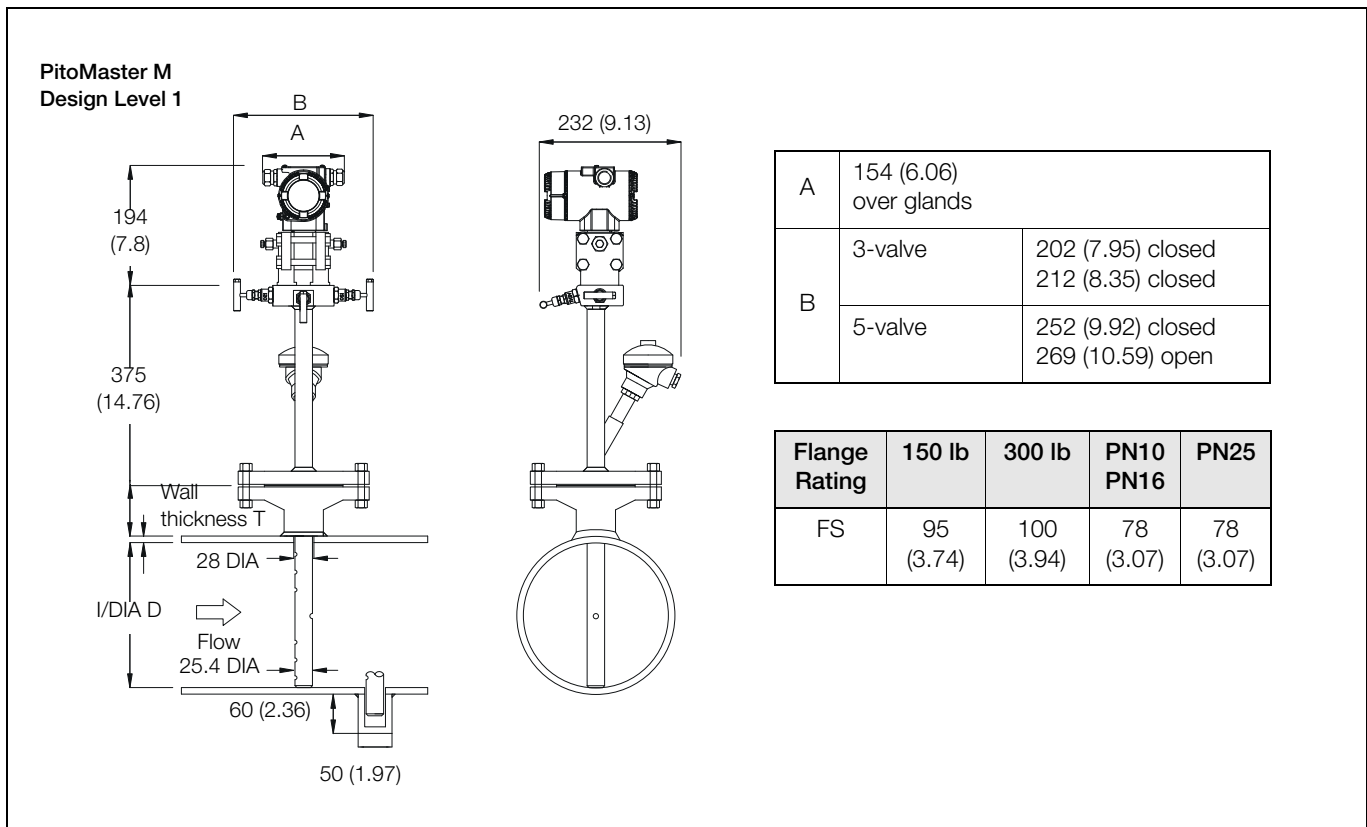

Fig. 2.7 FPD550 PitoMaster M Dimensions, Flanged Process Connection and Integral Temperature Measurement

2.2 Mounting

2.2.1 General

Select a location with sufficient clearance to install and remove PitoMaster.

Referring to Fig. 2.8, install PitoMaster:

- at right angles to the pipe run
- across the pipe diameter
- aligned with the pipe axis

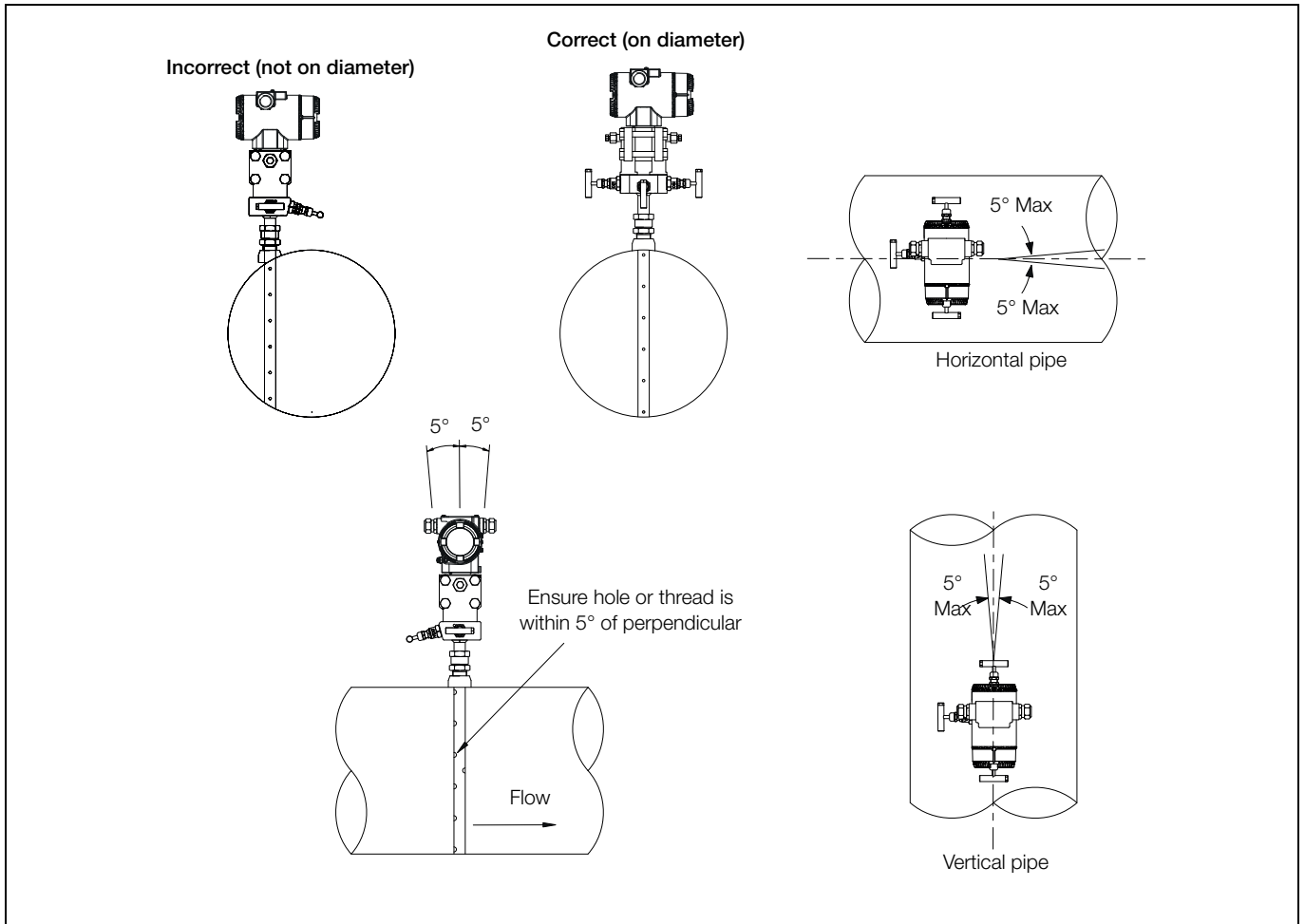

Fig. 2.8 PitoMaster Alignment

2.2.2 Horizontal Pipe Mounting – Gas

To ensure the instrument lines contain only gas, install PitoMaster with the instrument connections **above** the centre line of the pipe, at least 5 ° above the horizontal – see Fig. 2.9.

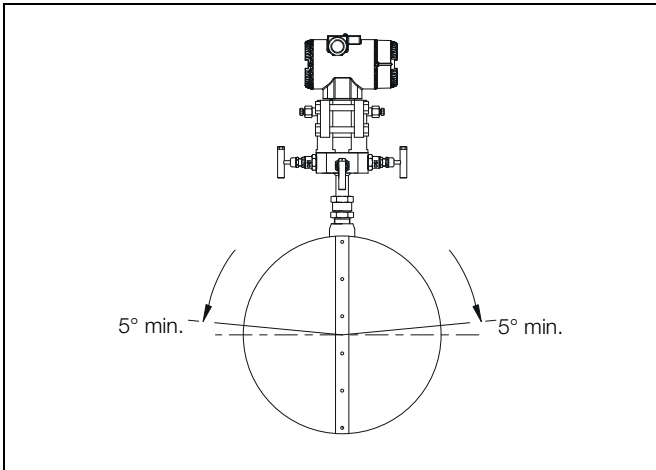

Fig. 2.9 Horizontal Pipe Mounting – Gas

2.2.3 Horizontal Pipe Mounting – Liquids

To ensure the instrument lines contain only the process liquid, install PitoMaster with the instrument connections **below** the centre line of the pipe, at least 5 ° below the horizontal – see Fig. 2.10.

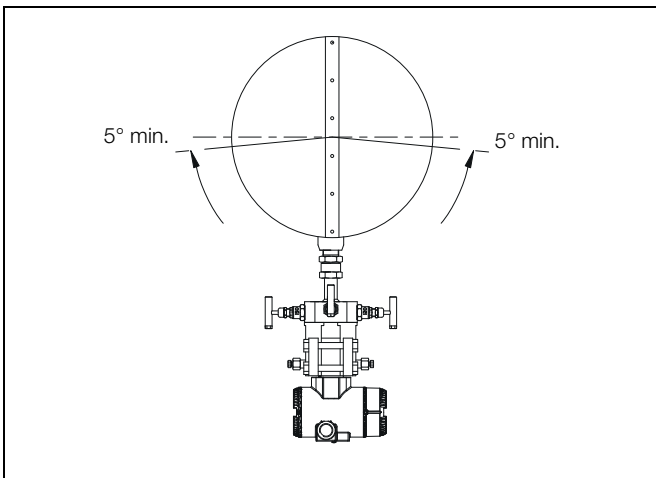

Fig. 2.10 Horizontal Pipe Mounting – Liquids

2.2.4 Horizontal Pipe Mounting – Steam

To ensure the instrument lines contain only steam, install PitoMaster with the instrument connections **at or below** the centre line of the pipe – see Fig. 2.11.

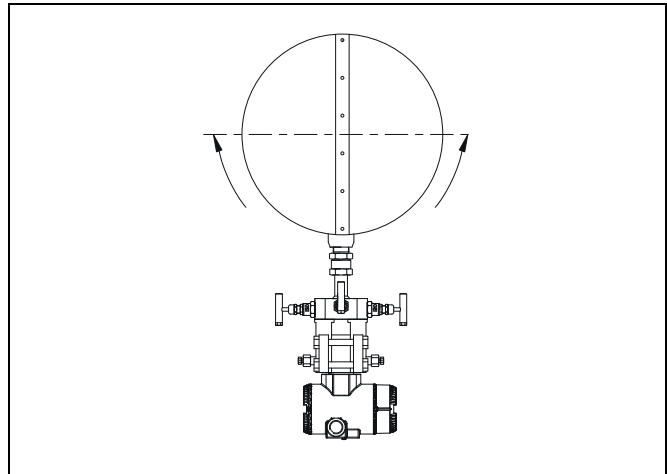

Fig. 2.11 Horizontal Pipe Mounting – Steam

2.2.5 Vertical Pipe Mounting – All Applications

Install only PitoMaster option VS in vertical pipelines.

To ensure an equal head of gas, liquid or steam in both instrument lines, PitoMaster option VS is designed so that the instrument lines are in the horizontal plane when the PitoMaster is installed.

Any lateral-mounting angle is suitable – see Fig. 2.12.

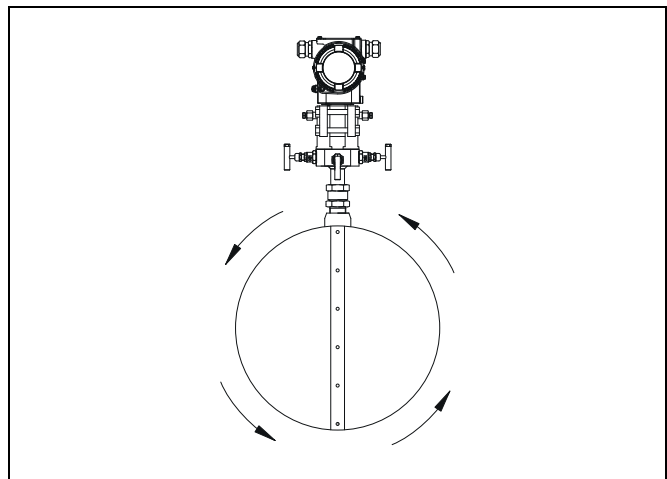

Fig. 2.12 Vertical Pipe Mounting – All Applications

2.3 Mechanical Installation

2.3.1 Threaded Process Connection

Install the PitoMaster as follows:

1. Select the required insertion position and mark the pipe.
2. Drill a 6 mm (0.24 in) pilot hole at the marked position, then drill to 28 mm (1.1 in.).

Note. If a full penetration weld is required, measure the inside diameter of the fittings supplied with the PitoMaster.

3. Align the threaded fitting concentrically over the hole and tack-weld in place.
4. Using a suitably sized and threaded length of pipe, check the threaded fitting is concentric and aligned correctly – see Fig. 2.8, page 11.
5. Weld the threaded fitting to the pipe.
6. Slide the compression-fitting assembly onto the PitoMaster.
7. Insert the PitoMaster through the threaded fitting into the pipe until it touches the opposite internal wall.
8. Apply appropriate sealant to the threads of the compression fitting.
9. Screw the compression fitting into the threaded fitting until hand-tight.
10. Turn the PitoMaster until the flow arrow is positioned correctly.
11. Holding the head of the PitoMaster with a wrench to maintain correct orientation, use a long wrench to tighten the compression fitting until approximately one thread is left exposed under the nut, ensuring the PitoMaster does not turn.
12. Check the PitoMaster is installed correctly and aligned.

2.3.2 Threaded Process Connection with End Support

Install the PitoMaster as follow:

1. Select the required insertion position and mark the pipe.
2. Drill a 6 mm (0.24 in) pilot hole at the marked position, then drill to 28 mm (1.1 in).

Note. If a full penetration weld is required, measure the inside diameter of the fittings supplied with the PitoMaster.

3. Align the threaded fitting concentrically over the hole and tack-weld in place.
4. Using a suitably sized and threaded length of pipe, check the threaded fitting is concentric and aligned correctly – see Fig. 2.8, page 11.
5. Weld the threaded fitting to the pipe.
6. Measure exactly 180° around the pipe circumference and mark the pipe.
7. Repeat steps 2 to 5.
8. Slide the compression-fitting assembly onto the PitoMaster.
9. Insert the PitoMaster through the threaded fitting into the pipe until it enters the opposite fitting.
10. Apply appropriate sealant to the threads of the support plug.

11. Referring to Fig. 2.13, screw support plug (A) into threaded fitting (B) and tighten, ensuring that:
 - a. support plug (A) contacts the PitoMaster (C)
 - b. the distance between the head of support plug (A) and the pipe wall does not exceed 60 mm (2.4 in).

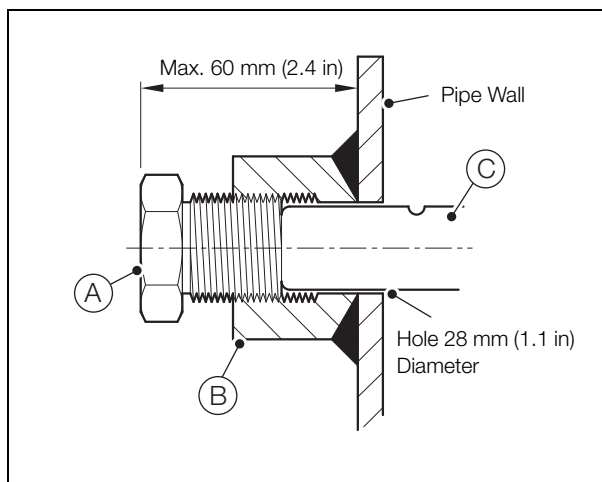

Fig. 2.13 Threaded Process Connection Support Plug

12. Apply appropriate sealant to the threads of the compression fitting.
13. Screw the compression fitting into the threaded fitting until hand-tight.
14. Turn the PitoMaster until the flow arrow is positioned correctly
15. Holding the head of the PitoMaster with a wrench to maintain correct orientation, use a long wrench to tighten the compression fitting until approximately one thread is left exposed under the nut, ensuring the PitoMaster does not turn.
16. Check the PitoMaster is installed correctly and aligned.

2.3.3 Flanged Process Connection

Install the PitoMaster as follows:

1. Install the flanged pipe fitting (stand-off) – see Section 2.3.3, page 14.
2. Position the gasket onto the PitoMaster flange and carefully insert the PitoMaster through the flanged pipe fitting (stand-off) until the two flanges mate squarely.
3. Turn the upper flange until the flow arrow is positioned correctly.
4. Fit the flange securing bolts and tighten equally and evenly, observing correct procedures appropriate to the flange.
5. Check the PitoMaster is installed correctly and aligned.

2.3.4 Flanged Process Connection with End Support

Install the PitoMaster as follows:

1. Install the flanged pipe fitting (stand-off) – see Section 2.4, page 15.
2. Measure exactly 180° around the pipe circumference and mark the pipe.
3. Drill a 6 mm (0.24 in) pilot hole at the marked position, then drill to 33 mm (1.3 in.).
4. Insert the PitoMaster through the flanged pipe fitting (stand-off) into the pipe and check that the tip protrudes through the hole in the opposite pipe wall when the two flanges mate squarely.
5. Position the end-support cup over the tip of the PitoMaster, ensuring the tip is concentric with the hole, and tack-weld the end-support cup in place.
6. Remove the PitoMaster and complete the support cup full-penetration weld.
7. Position the gasket on the PitoMaster flange and carefully insert the PitoMaster through the flanged pipe fitting (stand-off) until the two flanges mate squarely, ensuring the tip of the PitoMaster enters the end-support cup.
8. Turn the upper flange until the flow arrow is positioned correctly.
9. Fit the flange securing bolts and tighten equally and evenly, observing correct procedures appropriate to the flange.
10. Check the PitoMaster is installed correctly and aligned.

2.4 Flanged Pipe Fitting (Stand-Off) Installation

Note. This Section is applicable only to flanged PitoMaster models.

Install the flanged pipe fitting (stand-off) as follows:

1. Select the required insertion position and mark the pipe.
2. Drill a 6 mm (0.24 in) pilot hole at the marked position, then drill to 28 mm (1.1 in.).

Note. Every flanged pipe fitting (stand-off) is shaped to fit the pipe and is self-aligning on two bolt holes as standard.

3. Referring to Fig. 2.14:
 - a. Place the flanged pipe fitting (stand-off) (A) centrally over the drilled hole and align it correctly to the axis of the pipe (angle X) according to the number of bolt holes in the flange. Ensure it is perpendicular to the pipe axis and square to the pipe plane.
 - b. Use suitable spacers (B) to raise the flanged pipe fitting (stand-off) off the pipe to establish the necessary gap for full-penetration welding.
 - c. Tack-weld at four points (C) midway between the crotch and the skirt sections of the fitting.
 - d. Using a suitable piece of pipe, ensure the flanged pipe fitting (stand-off) is correctly aligned with the pipe (see Fig. 2.8, page 11) and concentric with the hole.
 - e. Remove the spacers (B).
 - f. Apply a full penetration root run completely around the base of the flanged pipe fitting (stand-off) at the clearly defined weld preparation line (D).
 - g. Make reinforcing welds at the crotch bevelled areas (E) of the flanged pipe fitting (stand-off) to provide maximum weld at the crotch tapering to a minimum at the skirt (F).

Caution. Weld only the bevelled portion of the flanged pipe fitting (stand-off) to prevent the integrity of the weld being compromised by any notch effect.

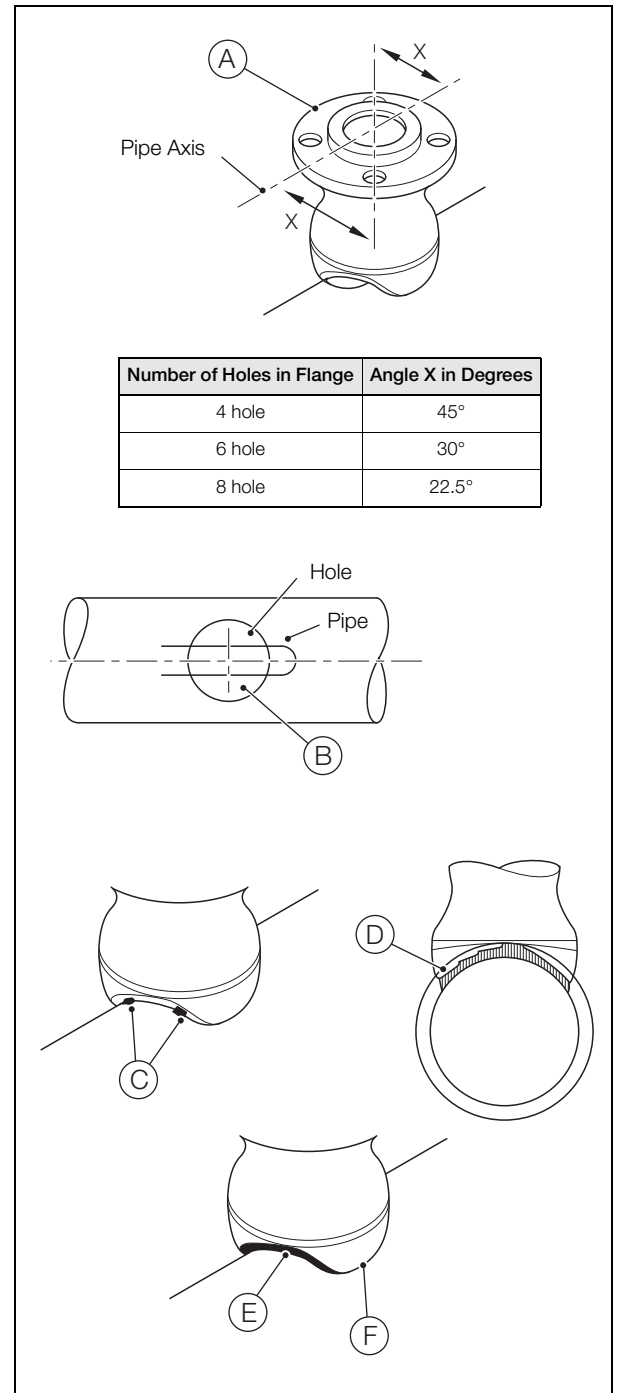

Fig. 2.14 Flanged Pipe Fitting (Stand-off) Installation

2.5 Remote RTD Installation

When the optional ABB remote RTD assembly (or any other RTD assembly) is used, weld a mounting boss to the pipeline at a location 6 diameters downstream of the center line of the PitoMaster – see Fig. 2.15. Drill and tap the boss to accommodate the RTD assembly (typically $\frac{3}{4}$ in. NPT for the ABB Remote RTD assembly).

Alternative RTD assemblies may be used and the installation method modified to suit, but the 6 diameter downstream separation distance between the RTD and the PitoMaster must be maintained.

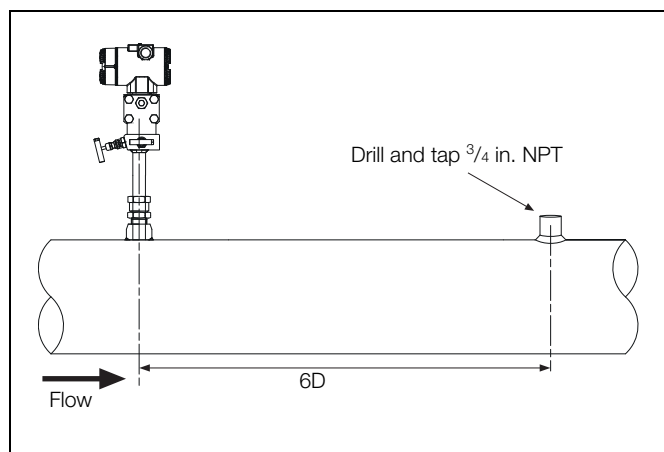

Fig. 2.15 Remote RTD Installation

3 Configuration

Note. If the meter has been supplied pre-configured by ABB, do not change parameter settings as this will cause erroneous meter readings.

To configure the PitoMaster, refer to the transmitter Operating Instructions (IM/267C/269C, IM/364 and SOI-266-XC-D).

4 Commissioning

4.1 Gas and Liquid Service

Caution. During the following procedure, wear Personal Protection Equipment appropriate for the process.

1. Install PitoMaster as described in Section 2.3, page 13:
 - for horizontal pipe mounting – gas, refer to Fig. 2.9.
 - for horizontal pipe mounting – liquid, refer to Fig. 2.10.
 - for vertical pipe mounting – liquid or gas, refer to Fig. 2.12.
2. Ensure the pipeline is full.
3. Gradually bring the pipeline up to normal operating pressure, checking for any leaks in the system. If leaks are detected, de-pressurize the pipeline and repair as necessary observing all local health and safety and environmental requirements.
4. When the system is at normal operating pressure and flow established, bleed the PitoMaster impulse lines using the drain/vent valves. Collect and dispose of any bleed liquids in accordance with the local environmental regulations.

Caution. Ensure the drain/vent valves are positioned so that process fluid is directed down and away from personnel when it is removed during the drain/vent operation.

The differential pressure transmitter is normally supplied zeroed at atmospheric conditions (unless otherwise specified). To ensure correct operation, it must be zeroed at the normal operating pressure of the process.

To zero the transmitter:

1. Ensure the pipeline is at the normal operating pressure and that the transmitter power supply is on.
2. Close the high pressure (HP) and low pressure (LP) isolation valves.
3. Open the equalization valve. The transmitter should now indicate a value close to zero.
4. Zero the differential pressure transmitter – refer to the transmitter's Operating Instructions (IM/267C/269C, IM/364 and SOI-266-XC-D).
5. Open the HP and LP isolation valves.
6. Close the equalization valve. The transmitter should now indicate flow. For information on fault diagnosis, refer to Section 5.1, page 18.

4.2 Steam Service

Note. Fill the impulse lines with water or condensate to ensure correct operation and to protect the transmitter from excessive temperatures.

1. Referring to Fig. 2.11, install PitoMaster as described in Section 2.3, page 13.
2. Ensure the process pipeline is empty and de-pressurized.
3. Connect a suitable water supply to the pipeline.
4. Open the drain/vent valves.

Caution. Ensure the drain/vent valves are positioned to direct process fluid down and away from personnel when they are opened during the drain/vent operation.

5. Open the HP and LP isolation valves and allow water to flow **slowly** into the impulse lines until an air-free flow is obtained from the drain/vent valves, indicating that the impulse lines are full.
6. Close the HP and LP isolation valves.
7. Close the drain/vent valves and disconnect the water supply.
8. Gradually bring the pipeline up to normal operating pressure, checking for any leaks in the system. If leaks are detected, de-pressurize the pipeline and repair as necessary observing all local health and safety and environmental requirements.

The differential pressure transmitter is normally supplied zeroed at atmospheric conditions (unless otherwise specified). To ensure correct operation, it must be zeroed at the normal operating pressure of the process.

To zero the transmitter:

1. Ensure the pipeline is at the normal operating pressure and that the transmitter power supply is on.
2. Close the HP and LP isolation valves.
3. Open the manifold equalization valve. The transmitter should now indicate a value close to zero.
4. Zero the differential pressure transmitter – refer to the transmitter's Operating Instructions (IM/267C/269C, IM/364 and SOI-266-XC-D).
5. Open the HP and LP isolation valves.
6. Close the equalization valve. The transmitter should now indicate flow.

5 Operation and Maintenance

5.1 Troubleshooting

Refer to the differential pressure transmitter's Operating Instructions (IM/267C/269C, IM/364 and SOI-266-XC-D) for procedures to be followed when error messages are shown on the transmitter display.

For other suspected problems, complete the following checks to ensure correct installation.

Direction of flow	Ensure the flow direction is in accordance with the arrow on the meter. If not, remove and reinstall the meter correctly.
Mounting orientation	Ensure the meter is correctly oriented to the pipework with regard to flow direction, pipeline and nature of the fluid. Incorrect orientation can lead to metering errors and in some cases may damage the meter.
Zeroing of the transmitter	Zero the differential pressure transmitter during installation and commissioning – see Section 4, page 17.
Manifold valves	The meter manifold is fitted with three valves – two on diametrically opposite sides of the meter (the HP and LP isolation valves) and one on the axis of the pipeline (the equalization valve) During measurement, ensure the equalization valve is fully closed and the HP and LP isolation valves are fully open.
Setup/configuration of the meter	Ensure the 4 to 20 mA output of the meter is correctly set and that any receiving equipment is configured for the same flowrate range. Refer to the differential pressure transmitter's Operating Instructions (IM/267C/269C, IM/364 and SOI-266-XC-D) for information on how to check the loaded configuration.

Table 5.1 Troubleshooting Checks

5.2 PitoMaster Removing

5.2.1 Removing Threaded Process Connection

Remove the PitoMaster as follows:

Warning. Failure to reduce the pipe pressure to a safe level and remove all hazardous material prior to removing the PitoMaster could result in serious injury to personnel.

1. Reduce pipe pressure to a safe level and remove all hazardous material.
2. Remove the compression fitting.
3. Remove the PitoMaster.

5.2.2 Removing Flanged Process Connection

Remove the PitoMaster as follows:

Warning. Failure to reduce the pipe pressure to a safe level and remove all hazardous material prior to removing the PitoMaster could result in serious injury to personnel.

1. Reduce pipe pressure to a safe level and remove all hazardous material.
2. Remove the flange securing bolts.
3. Remove the PitoMaster.

5.3 Examination

Note.

- The frequency of examination depends upon the abrasive or corrosive nature of the process fluid, for example:
 - Steam – annually
 - Clean fluid – every 2 or 3 years.
- In the case of a new process or plant, examine the meter during each routine maintenance period until the wear of each installation, relative to others, can be assessed.

Examine the meter in accordance with the instructions in Section 2.3, page 13.

5.4 PitoMaster Refitting

5.4.1 Refitting Threaded Process Connection

Refit the PitoMaster as follows:

1. Slide the compression-fitting assembly onto the PitoMaster.
2. Insert the PitoMaster through the threaded fitting into the pipe until it either touches the opposite internal wall (**models without end support**) or enters the opposite fitting (**models with end support**).
3. Apply appropriate sealant to the threads of the compression fitting.
4. Screw the compression fitting into the threaded fitting until hand-tight.
5. Turn the PitoMaster until the flow arrow is positioned correctly.
6. Holding the head of the PitoMaster with a wrench to maintain correct orientation, use a long wrench to tighten the compression fitting until approximately one thread is left exposed under the nut, ensuring the PitoMaster does not turn.
7. Check the PitoMaster is installed correctly and aligned.

5.4.2 Refitting Flanged Process Connection

Refit the PitoMaster as follows:

1. Position the gasket onto the PitoMaster flange and carefully insert the PitoMaster through the flanged pipe fitting (stand-off) (ensuring the tip touches the opposite internal wall – **models without end support**, or enters the opposite fitting – **models with end support**) until the two flanges mate squarely.
2. Turn the upper flange until the flow arrow is positioned correctly.
3. Fit the flange securing bolts and tighten equally and evenly, observing correct procedures appropriate to the flange.
4. Check the PitoMaster is installed correctly and aligned.

5.5 Remotely Mounted RTD Replacement

To replace the RTD:

1. Ensure the transmitter is powered-down.
2. Remove the transmitter termination cover.
3. Disconnect the RTD wiring from the terminals and remove it from the cable entry.
4. Unscrew the RTD assembly from the thermowell. **DO NOT** remove the thermowell from the pipeline.

Caution. If there is **any** suspicion that process pressure has penetrated the thermowell, *completely depressurize the pipeline before removing the RTD assembly*. Additional precautions relating to the nature of the process fluid may also be required.

5. Screw the replacement RTD assembly into the thermowell.
6. Route the RTD wiring through the cable entry and reconnect to the appropriate terminals – refer to the transmitter Operating Instructions (IM/267C/269C).
7. Power-up the transmitter.

6 Specification – General

Fluids

Liquids, gases and saturated steam

Line sizes

100 to 600 mm (4 to 24 in.)

Probe

13 or 25 mm (1/2 or 1 in.) diameter probe with optional end support

Process connection

Threaded BSPT or NPT

Flanged DN25 (1 in.) or DN 40 (1 1/2 in.) to ANSI 150RF, 300RF or NP10/16, NP25/40

Construction materials

Probe

316 stainless steel

Manifold

316 stainless steel

Manifold seals

PTFE

Flange

316 stainless steel

Weld adaptor

A105 carbon steel; 316 stainless steel

Process isolating diaphragms

Hastelloy C-276™

(AISI 316 L stainless steel gold plated for Hydrogen service) packing

Process flanges, adapters, plugs and drain/vent valves

AISI 316 L stainless steel

Sensor fill fluid

Silicone oil

Inert fill (Halocarbon™ 4.2 or Galden™)

Manifold

Integral 3-valve manifold (optional 5-valve manifold)

Output signal

Two-wire, 4 to 20 mA, selected for square-root output

Low flow cut-off facility

HART® communication provides digital process variable

(%, mA or engineering units) superimposed on 4 to 20 mA signal, with protocol based on Bell202 FSK standard

Optional Profibus PA, Foundation Fieldbus or Modbus communications

Accuracy

Uncalibrated

PitoMaster V:

±1.4 % of actual flow

PitoMaster M:

±1.15 % of actual flow

Flow range

8:1

Maximum pressure

50 Bar @ 38 °C (725 psi @ 100 °F)

Maximum process temperature

180 °C (356 °F)

At the transmitter sensor

Silicone oil filled sensor F to H:

–40 to 121 °C (–40 to 250 °F)

Silicone oil filled sensor A, B, E:

–25 to 121 °C (–13 to 250 °F)

Inert (Galden) filled sensor F to H:

–20 to 100 °C (–4 to 212 °F)

Inert (Galden) filled sensor E:

–10 to 100 °C (14 to 212 °F)

Inert (Halocarbon) filled sensor F to H:

–20 to 100 °C (–4 to 212 °F)

Inert (Halocarbon) filled sensor E:

–10 to 100 °C (14 to 212 °F)

IMPORTANT

For hazardous atmosphere applications see the temperature range specified on the certificate/approval relevant to the type of protection

Ambient Temperature Limits

Note. LCD display may not be clearly readable below $-20\text{ }^{\circ}\text{C}$ ($-4\text{ }^{\circ}\text{F}$) or above $70\text{ }^{\circ}\text{C}$ ($158\text{ }^{\circ}\text{F}$)

PitoMaster V

Up to -40 and $85\text{ }^{\circ}\text{C}$ (-40 and $185\text{ }^{\circ}\text{F}$)

LCD display limits:

-40 and $85\text{ }^{\circ}\text{C}$ (-40 and $185\text{ }^{\circ}\text{F}$)

PitoMaster M

Transmitter:

-40 to $85\text{ }^{\circ}\text{C}$ (-40 to $185\text{ }^{\circ}\text{F}$)

LCD display limits:

-20 to $70\text{ }^{\circ}\text{C}$ (-4 to $158\text{ }^{\circ}\text{F}$)

All above may be further restricted depending on individual sensor capsule filling fluid

Storage limits

-50 to $85\text{ }^{\circ}\text{C}$ (-58 to $185\text{ }^{\circ}\text{F}$)

LCD integral display:

-40 to $85\text{ }^{\circ}\text{C}$ (-40 to $185\text{ }^{\circ}\text{F}$)

Integral display

PitoMaster V

Wide screen LCD, 128×64 pixel, 52.5×27.2 mm
(2.06×1.07 in.) dot matrix

Multi language

4 keys for device configuration and management

Totalized and instantaneous flow indication

Display may also indicate diagnostic messages and provides configuration facilities

PitoMaster M

19-segment alphanumeric display (2-line, 6-character) with additional bar chart display. Back illumination optional.

Environmental limits

Electromagnetic compatibility (EMC)

Complies with EN 61326 and NAMUR NE-21

Surge immunity level (with surge protector)

4 kV (according to IEC 1000-4-5 EN 61000-4-5)

Pressure equipment directive (PED)

Complies with 97/23/EEC Category III Module H

Humidity

Relative humidity:

up to 100 %

Condensing, icing:

admissible

Vibration resistance

Accelerations up to 2 g at frequency up to 1000 Hz
(according to IEC 60068-2-6)

Shock resistance

Acceleration:

50 g

Duration:

11 ms (according to IEC 60068-2-27)

Wet and dust-laden atmospheres

The meter is dust and sand tight and protected against immersion effects as defined by EN 60529 (1989) to IP 67 (IP 68 on request) or by NEMA to 4X or by JIS to C0920. IP65 with Harting Han connector.

Hazardous atmospheres

With or without integral display

Combined ATEX code EW (= E1 + E2 + E3 below)

Combined ATEX and FM Approvals code EN

(= E1 + E2 + E3 + E4 + E6 below)

Intrinsic safety:

ATEX Europe (code E1)

II 1/2 G Ex ia IIC T6/T5/T4; IP67

II 1 D Ex iaD 20 T85 °C

II 1/2 D Ex iaD 21 T85 °C; IP67

Explosion proof:

ATEX Europe (code E2)

II 1/2 G Ex d IIC T6

II 1/2 D Ex tD A21 T85 °C ($-50\text{ }^{\circ}\text{C} \bullet \text{Ta} \bullet +75\text{ }^{\circ}\text{C}$); IP67

Type 'N':

ATEX Europe (code E3) type examination

II 3 G Ex nL IIC T6/T5/T4

II 3 D Ex tD A22 T85 °C; IP67

FM Approvals US (code E6) and Canada (code E4)

Explosion proof (US):

Class I, Div. 1, Groups A, B, C, D

Explosion proof (Canada):

Class I, Div. 1, Groups B, C, D

Dust ignition proof:

Class II, Div. 1, Groups E, F, G

Suitable for:

Class II, Div. 2, Groups F, G; Class III, Div.1, 2

Non-incendive:

Class I, Div. 2, Groups A, B, C, D

Intrinsically safe:

Class I, II, III, Div. 1, Groups A, B, C, D, E, F, G

Class I, Zone 0 AEx ia IIC T6/T4, Zone 0 (FM US)

Class I, Zone 0 Ex ia IIC T6/T4, Zone 0 (FM Canada)

FM Approvals US

Intrinsically safe (code EA):

Class I; Division 1; Groups A, B, C, D;

Class I; Zone 0; Group IIC; AEx ia IIC

Explosion proof (code EB):

Class I, Division 1, Groups A, B, C, D;

Class II/III, Division 1, Groups E, F, G

Refer to certificates for ambient temperature ranges (within the limits – 50 to 85 °C) related to the different temperature classes

CSA Approvals Canada (code EE):

Explosion proof:

Class I, Division 1, Groups B, C, D;

Class II/III, Division 1, Groups E, F, G

Weights

Typical product weights in kg excluding pipe fittings and end supports

Size mm (in.)	Threaded	Flanged 1 1/2 in. ANSI 150lb	Flanged 1 1/2 in. ANSI 300lb	Flanged DN40 PN10/16	Flanged DN40 PN25
100 (4)	10	12	13	12	12
150 (6)	10	12	13	13	13
200 (8)	10	12	13	13	13
250 (10)	11	12	14	13	13
300 (12)	11	12	14	13	13
350 (14)	11	12	14	13	13
400 (16)	11	12	14	13	13
450 (18)	11	13	14	13	13
500 (20)	11	13	14	13	13
600 (24)	11	13	14	13	13

Weight adders:

5 valve manifold +1 kg

PitoMaster V design level 2 (SS) +2 kg

PitoMaster M design level 1 (SS) +1 kg

DP span

Sensor code	Upper range limit (URL)	Minimum span
A	1 kPa	0.05 kPa
	10 mbar	0.5 mbar
	4 in. H ₂ O	0.2 in. H ₂ O
B	4 kPa	0.2 kPa
	40 mbar	1.4 mbar
	16 in. H ₂ O	0.56 in. H ₂ O
E	16 kPa	0.54 kPa
	160 mbar	1.6 mbar
	64 in. H ₂ O	0.65 in. H ₂ O
F	40 kPa	0.4 kPa
	400 mbar	4 mbar
	160 in. H ₂ O	1.6 in. H ₂ O
G	65 kPa	0.65 kPa
	650 mbar	6.5 mbar
	260 in. H ₂ O	2.6 in. H ₂ O
H	160 kPa	1.6 kPa
	1600 mbar	16 mbar
	642 in. H ₂ O	6.4 in. H ₂ O

DS/FPD550-EN

Notes

Products and customer support

Automation Systems

For the following industries:

- Chemical & Pharmaceutical
- Food & Beverage
- Manufacturing
- Metals and Minerals
- Oil, Gas & Petrochemical
- Pulp and Paper

Drives and Motors

- AC and DC Drives, AC and DC Machines, AC Motors to 1kV
- Drive Systems
- Force Measurement
- Servo Drives

Controllers & Recorders

- Single and Multi-loop Controllers
- Circular Chart and Strip Chart Recorders
- Paperless Recorders
- Process Indicators

Flexible Automation

- Industrial Robots and Robot Systems

Flow Measurement

- Electromagnetic Flowmeters
- Mass Flowmeters
- Turbine Flowmeters
- Wedge Flow Elements

Marine Systems & Turbochargers

- Electrical Systems
- Marine Equipment
- Offshore Retrofit and Refurbishment

Process Analytics

- Process Gas Analysis
- Systems Integration

Transmitters

- Pressure
- Temperature
- Level
- Interface Modules

Valves, Actuators and Positioners

- Control Valves
- Actuators
- Positioners

Water, Gas & Industrial Analytics Instrumentation

- pH, Conductivity and Dissolved Oxygen Transmitters and Sensors
- Ammonia, Nitrate, Phosphate, Silica, Sodium, Chloride, Fluoride, Dissolved Oxygen and Hydrazine Analyzers
- Zirconia Oxygen Analyzers, Katharometers, Hydrogen Purity and Purge-gas Monitors, Thermal Conductivity

Customer support

We provide a comprehensive after sales service via a Worldwide Service Organization. Contact one of the following offices for details on your nearest Service and Repair Centre.

UK

ABB Limited
Tel: +44 (0)1453 826661
Fax: +44 (0)1453 829671

USA

ABB Inc.
Tel: +1 215 674 6000
Fax: +1 215 674 7183

Client Warranty

Prior to installation, the equipment referred to in this manual must be stored in a clean, dry environment, in accordance with the Company's published specification. Periodic checks must be made on the equipment's condition. In the event of a failure under warranty, the following documentation must be provided as substantiation:

- A listing evidencing process operation and alarm logs at time of failure.
- Copies of all storage, installation, operating and maintenance records relating to the alleged faulty unit.

Contact us

ABB Limited

Process Automation

Salterbeck Trading Estate
Workington, Cumbria
CA14 5DS
UK

Tel: +44 (0)1946 830 611

Fax: +44 (0)1946 832 661

ABB Inc.

Process Automation

125 E. County Line Road
Warminster
PA 18974
USA

Tel: +1 215 674 6000

Fax: +1 215 674 7183

www.abb.com

Note

We reserve the right to make technical changes or modify the contents of this document without prior notice. With regard to purchase orders, the agreed particulars shall prevail. ABB does not accept any responsibility whatsoever for potential errors or possible lack of information in this document.

We reserve all rights in this document and in the subject matter and illustrations contained therein. Any reproduction, disclosure to third parties or utilization of its contents in whole or in parts – is forbidden without prior written consent of ABB.

Copyright© 2011 ABB

All rights reserved

3KXF511551R4201

OI/FPD50-EN 12.2011