

OriMaster M

Compact orifice flowmeter



The Company

We are an established world force in the design and manufacture of measurement products for industrial process control, flow measurement, gas and liquid analysis and environmental applications.

As a part of ABB, a world leader in process automation technology, we offer customers application expertise, service and support worldwide.

We are committed to teamwork, high quality manufacturing, advanced technology and unrivalled service and support.

The quality, accuracy and performance of the Company's products result from over 100 years experience, combined with a continuous program of innovative design and development to incorporate the latest technology.

EN ISO 9001:2000



Cert. No. Q 05907

EN 29001 (ISO 9001)



Lenno, Italy – Cert. No. 9/90A

Stonehouse, U.K.



Electrical Safety

This equipment complies with the requirements of CEI/IEC 61010-1:2001-2 'Safety Requirements for Electrical Equipment for Measurement, Control and Laboratory Use'. If the equipment is used in a manner NOT specified by the Company, the protection provided by the equipment may be impaired.

Symbols

One or more of the following symbols may appear on the equipment labelling:

	Warning – Refer to the manual for instructions
	Caution – Risk of electric shock
	Protective earth (ground) terminal
	Earth (ground) terminal

	Direct current supply only
	Alternating current supply only
	Both direct and alternating current supply
	The equipment is protected through double insulation

Information in this manual is intended only to assist our customers in the efficient operation of our equipment. Use of this manual for any other purpose is specifically prohibited and its contents are not to be reproduced in full or part without prior approval of the Technical Publications Department.

Health and Safety

To ensure that our products are safe and without risk to health, the following points must be noted:

1. The relevant sections of these instructions must be read carefully before proceeding.
2. Warning labels on containers and packages must be observed.
3. Installation, operation, maintenance and servicing must only be carried out by suitably trained personnel and in accordance with the information given.
4. Normal safety precautions must be taken to avoid the possibility of an accident occurring when operating in conditions of high pressure and/or temperature.
5. Chemicals must be stored away from heat, protected from temperature extremes and powders kept dry. Normal safe handling procedures must be used.
6. When disposing of chemicals ensure that no two chemicals are mixed.

Safety advice concerning the use of the equipment described in this manual or any relevant hazard data sheets (where applicable) may be obtained from the Company address on the back cover, together with servicing and spares information.

Contents

1	General Safety Information	2
1.1	User Guidelines	2
1.2	Permissible Process Media (fluids)	2
1.3	Technical Limit Values	2
1.4	Safety Precautions	2
1.5	Potential Safety Hazards	2
2	Installation	3
2.1	General	3
2.1.1	Upstream Straight Pipe Requirements to ISO 5167-2:2003	3
2.1.2	Weight	3
2.1.3	Dimensions	4
2.2	Meter Orientation	6
2.2.1	Horizontal Pipe Mounting – Gas	6
2.2.2	Horizontal Pipe Mounting – Liquids & Steam	6
2.2.3	Vertical Pipe Mounting – Liquid & Gas (Upward Flow)	7
2.3	Mechanical Installation	8
2.4	Remote RTD Installation	9
3	Configuration	9
4	Commissioning	10
4.1	Gas and Liquid Service	10
4.2	Steam Service	10
5	Operation and Maintenance	11
5.1	Troubleshooting	11
5.2	Dismantling	11
5.3	Examination	11
5.4	Replacing of Removable Plate	12
5.5	Reassembly	12
5.6	Remotely Mounted RTD Replacement	12
6	Specification – General	13
7	Specification	15

1 General Safety Information

Warning.

- The Pressure Equipment described in this manual is supplied, where appropriate, in accordance with the European Directive 97/23/EC and is designed to work in pressurized systems. Take care when installing all equipment and follow the instructions given. Failure to do this could result in damage to equipment and create possible hazards to operators and other equipment. Only use the equipment on the process for which it is designed. Install the equipment into a system that has been designed to allow for venting or draining of the process. For the necessary safety requirements refer to the appropriate instructions in this manual.
- Do not exceed the pipe vibration levels stated in the Specification (see Section 6, page 13). Excessive vibration could result in damage to the equipment and create possible hazards to other equipment and operators.

1.1 User Guidelines

Correct use includes the following:

- Operation within the technical limit values.
- Observing and following the information provided on permissible media (fluids).
- Observing and following the instructions provided in the operating manuals.
- The following uses are not permitted:
 - Operation as a flexible adaptor in piping; for example, to compensate for pipe offsets, pipe vibrations and/or pipe expansions.
 - Use as a climbing aid; for example, for assembly purposes.
 - Use as a support for external loads; for example, as a support for piping.
 - Material gain; for example, by painting over the type plate or welding or soldering on parts.
 - Repairs, modifications, supplements or the installation of spare parts. These are permitted only if performed as described in the operating manual. More extensive work must be approved by ABB – the Company accepts no liability for unauthorized work.

The operating, maintenance and repair conditions that are stated in this manual must be observed. The Company accepts no liability for damage caused by usage that is incorrect or unprofessional.

1.2 Permissible Process Media (fluids)

Process media may be used only if:

- It can be assured that the physical and chemical properties of the pressure-bearing materials that come into contact with the process medium are not reduced from that required for operational safety, during the expected lifetime of the equipment.
- Process media with unknown properties for erosion and/or corrosion may be used only if the operator can perform regular and suitable tests to assure the safe condition of the equipment.

1.3 Technical Limit Values

The equipment is intended for use only within the technical limit values specified on the data plate and in the Specification (see Section 6, page 13), including those for:

- The maximum working pressure.
- The maximum and minimum operating temperatures.
- The maximum vibration level stated in the Specification (see Section 6, page 13).

In addition, all connected pipework must be installed as it was designed, to ensure that there is no possibility of leakage or any undue stresses or strain acting upon it.

1.4 Safety Precautions

Instructions and procedures in this manual may require special precautions to ensure the safety of personnel performing the operations. Explosions could result in death or serious injury; therefore refer to the **Warnings** in the transmitter Operating Instructions (IM/267C/269C) before performing any operation in this manual.

1.5 Potential Safety Hazards

The following potential safety hazards are associated with operating the system:

- Electrical (line voltage)
- Product (FPD500) weight

2 Installation

2.1 General

2.1.1 Upstream Straight Pipe Requirements to ISO 5167-2:2003

Fitting	$\beta = 0.4$	$\beta = 0.65$
Conical reducer (2D – D)	5D	12D
Conical expander (0.5D – D)	12D	28D
Single 90 ° bend	16D	44D
2 off 90 ° bends in same plane	10D	44D
2 off 90 ° bends in different plane	50D	60D

Where D = pipe diameter

2.1.2 Weight

Size in mm (in.)	Weight in kg (lbs)
25 (1)	8 (17.6)
40 (1½)	8.5 (18.7)
50 (2)	9 (19.8)
80 (3)	10 (22)
100 (4)	11 (24.2)
150 (6)	13 (28.6)
200 (8)	15 (33)
250 (10)	18 (39.7)
300 (12)	20 (44.1)

2.1.3 Dimensions

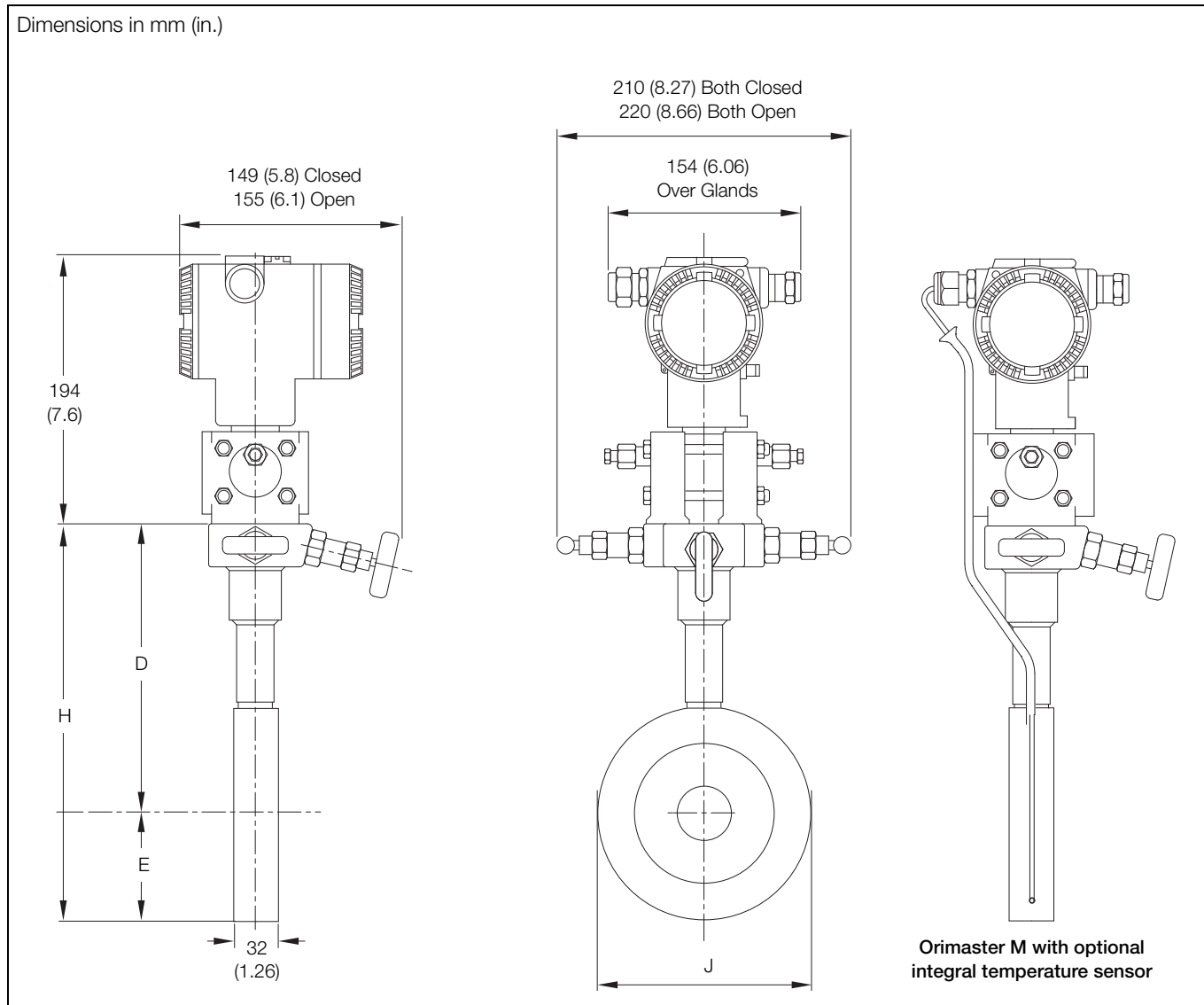

Fig. 2.1 OriMaster M (Design Level 1) 3-Valve Dimensions

Size	H	J	E (J/2)	D (H - E)
25 (1)	180 (7.1)	50.8 ±1 (2.00 ±0.04)	25.4 ±0.5 (1.00 ±0.02)	154.6 ±5 (6.10 ±0.20)
40 (1½)	203 (8)	73.2 ±1 (2.88 ±0.04)	36.6 ±0.5 (1.44 ±0.02)	166.4 ±5 (6.56 ±0.20)
50 (2)	221 (8.7)	92.1 ±1 (3.63 ±0.04)	46.05 ±0.5 (1.81 ±0.02)	174.95 ±5 (6.89 ±0.20)
80 (3)	257 (10.12)	127 ±1 (4.99 ±0.04)	63.5 ±0.5 (2.50 ±0.02)	193.5 ±5 (7.62 ±0.20)
100 (4)	314 (12.36)	157.2 ±1 (6.19 ±0.04)	78.6 ±0.5 (3.09 ±0.02)	235.4 ±5 (9.27 ±0.20)
150 (6)	372 (14.65)	215.9 ±1 (8.50 ±0.04)	107.95 ±0.5 (4.25 ±0.02)	264.05 ±5 (10.40 ±0.20)
200 (8)	426 (16.77)	269.9 ±1 (10.63 ±0.04)	134.95 ±0.5 (5.31 ±0.02)	291.05 ±5 (11.46 ±0.20)
250 (10)	502 (19.76)	323.8 ±1 (12.75 ±0.04)	161.9 ±0.5 (6.37 ±0.02)	340.1 ±5 (13.39 ±0.20)
300 (12)	560 (22.04)	381.0 ±1 (15.00 ±0.04)	190.5 ±0.5 (7.5 ±0.02)	369.5 ±5 (14.55 ±0.20)

Table 2.1 OriMaster M (Design Level 1) 3-Valve Sizing Table – Dimensions in mm (in.)

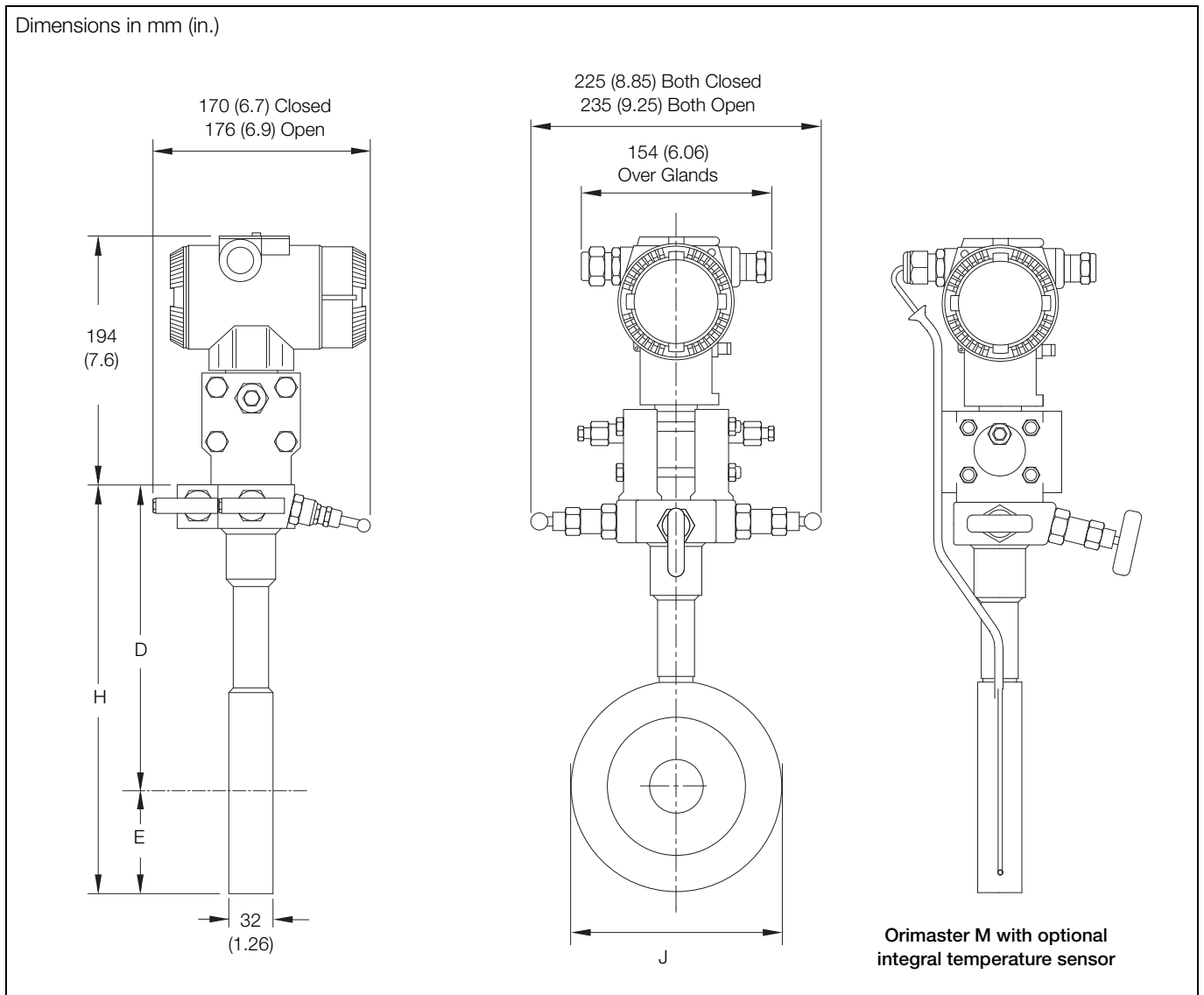

Fig. 2.2 OriMaster M (Design Level 1) 5-Valve Dimensions

Size	H	J	E (J/2)	D (H - E)
25 (1)	180 (7.1)	50.8 ±1 (2.00 ±0.04)	25.4 ±0.5 (1.00 ±0.02)	154.6 ±5 (6.10 ±0.20)
40 (1½)	203 (8)	73.2 ±1 (2.88 ±0.04)	36.6 ±0.5 (1.44 ±0.02)	166.4 ±5 (6.56 ±0.20)
50 (2)	221 (8.7)	92.1 ±1 (3.63 ±0.04)	46.05 ±0.5 (1.81 ±0.02)	174.95 ±5 (6.89 ±0.20)
80 (3)	257 (10.12)	127 ±1 (4.99 ±0.04)	63.5 ±0.5 (2.50 ±0.02)	193.5 ±5 (7.62 ±0.20)
100 (4)	314 (12.36)	157.2 ±1 (6.19 ±0.04)	78.6 ±0.5 (3.09 ±0.02)	235.4 ±5 (9.27 ±0.20)
150 (6)	372 (14.65)	215.9 ±1 (8.50 ±0.04)	107.95 ±0.5 (4.25 ±0.02)	264.05 ±5 (10.40 ±0.20)
200 (8)	426 (16.77)	269.9 ±1 (10.63 ±0.04)	134.95 ±0.5 (5.31 ±0.02)	291.05 ±5 (11.46 ±0.20)
250 (10)	502 (19.76)	323.8 ±1 (12.75 ±0.04)	161.9 ±0.5 (6.37 ±0.02)	340.1 ±5 (13.39 ±0.20)
300 (12)	560 (22.04)	381.0 ±1 (15.00 ±0.04)	190.5 ±0.5 (7.50 ±0.02)	369.5 ±5 (14.55 ±0.20)

Table 2.2 OriMaster M (Design Level 1) 5-Valve Sizing Table – Dimensions in mm (in.)

2.2 Meter Orientation

Caution. When installing OriMaster M, ensure that the drain/vent valves are positioned to direct the process medium away from personnel and equipment when it is removed during drain and vent operations.

For all meter orientations, ensure the arrow on the meter body is aligned correctly with the direction of flow in the pipeline.

2.2.1 Horizontal Pipe Mounting – Gas

To ensure that condensate drains back into the pipe, mount the meter **above** the pipe, at least 30 degrees above the horizontal – see Fig. 2.3.

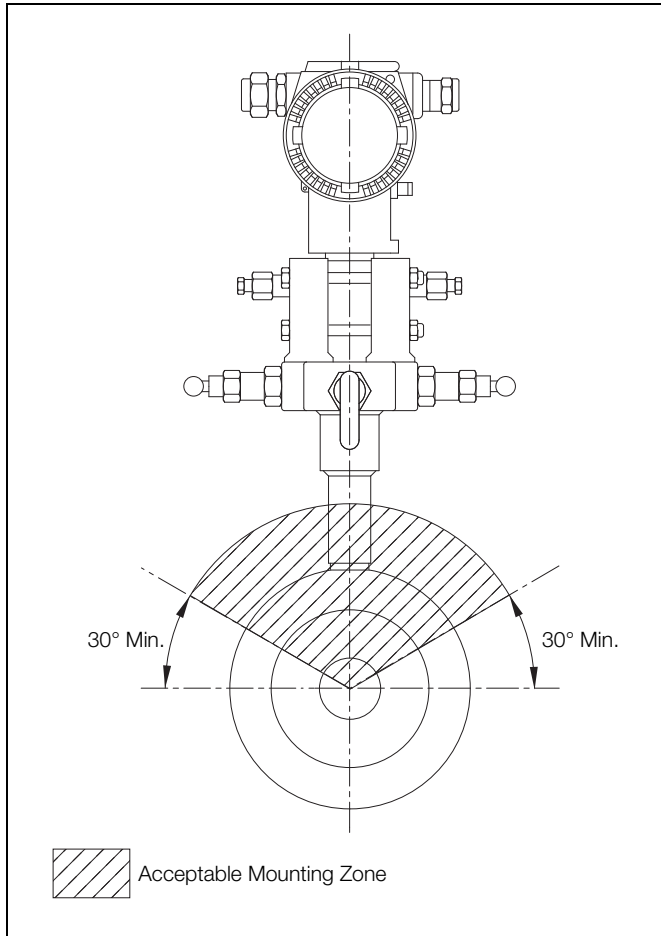

Fig. 2.3 Horizontal Pipe Mounting – Gas

2.2.2 Horizontal Pipe Mounting – Liquids & Steam

To ensure that gases vent back into the pipe, mount the meter **below** the pipe, at least 45 degrees below the horizontal – see Fig. 2.4.

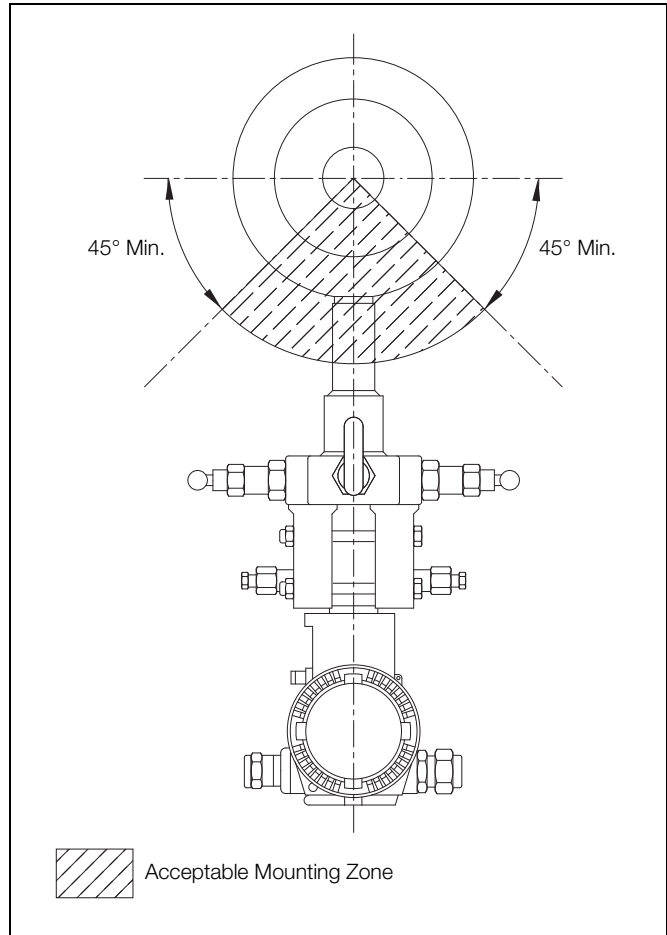

Fig. 2.4 Horizontal Pipe Mounting – Liquids & Steam

2.2.3 Vertical Pipe Mounting – Liquid & Gas (Upward Flow)
Install the meter as shown In Fig. 2.5.

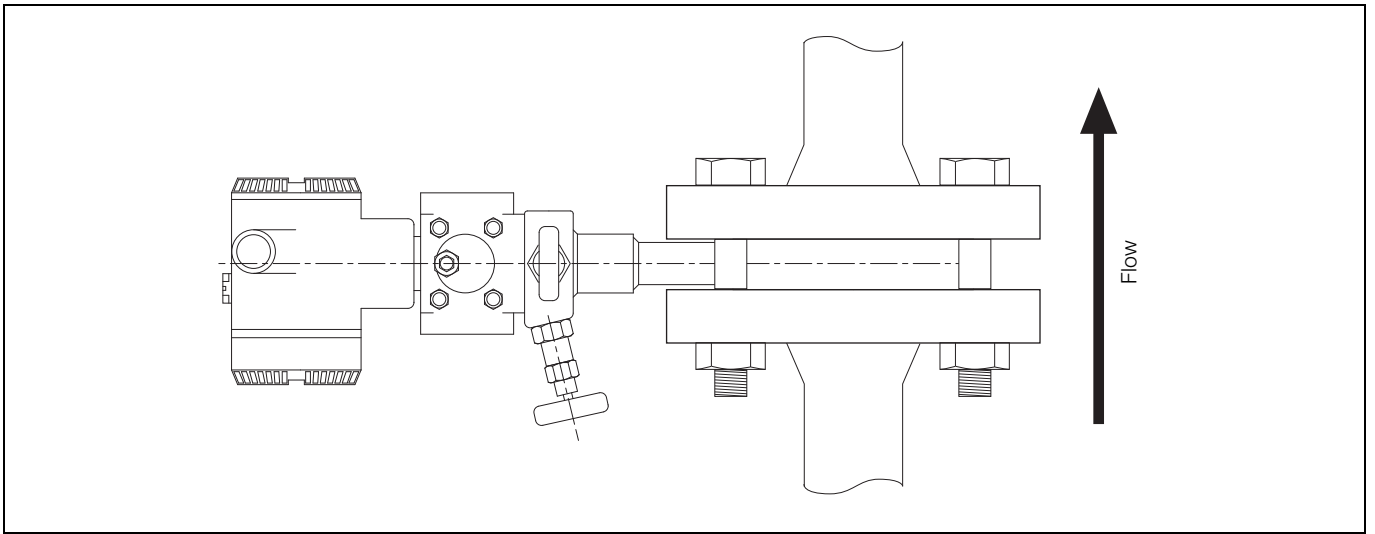

Fig. 2.5 Vertical Pipe Mounting – Liquid or Gas

2.3 Mechanical Installation

Note. Before installation, read Section 1, General Safety Information.

Caution. Neither the transmitter nor the bore of the orifice plate is designed to withstand the weight of the meter. Do not lift the meter by either the orifice plate bore or the transmitter. Lift the meter only by the neck.

Note. Accurate centralization in the pipeline is critical to OriMaster's performance. For information on the effects of incorrect centralization, refer to standard ISO5167:2003.

To install:

1. Check the Tag Number of the meter to ensure it is the correct unit for the location.
2. Ensure all weld outlines in the pipeline where OriMaster M is to be installed are even. Grind off any protrusions inside the pipe and ensure that the inside of the pipe is smooth and clean.
3. Ensure that any specialized cleaning requirements are performed (for example, those specifically for oxygen/pharmaceutical applications).
4. Examine the meter and the flange faces and ensure that:
 - a. the faces of the orifice plate are free from scratches and are not buckled
 - b. the square edge of the orifice plate is not worn (no light is reflected from the square edge)
 - c. the orifice plate bore is not marked or distorted
 - d. the gasket surfaces are clean

Replace defective components as necessary.

5. Fit sufficient bolts in the lower part of the pipeline flanges to retain the meter in place.
6. Locate the centralizing tool on the meter body.

Note. One of two types of centralizing tool is supplied with the meter – see Fig. 2.6.

7. Place the correct gaskets on both sides of the meter body and align them correctly to the orifice plate, ensuring they do not protrude into the pipe bore.

8. Insert the meter and centralizing tool between the pipeline flanges ensuring that:
 - a. The meter's equalizing valve is pointing upstream of the fluid flow.
 - b. The meter is oriented correctly depending on the type of installation – see Figs. 2.3, 2.4, and 2.5.

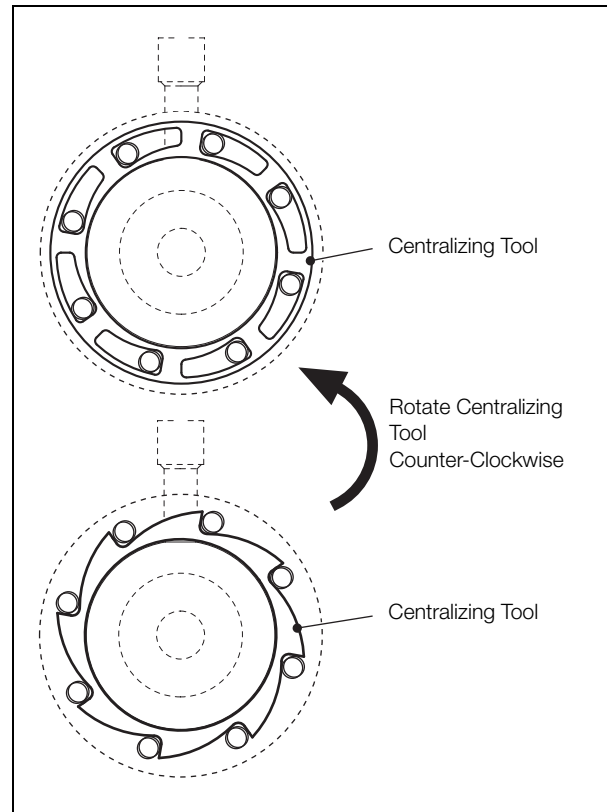

*Fig. 2.6 Centralizing Tool
(meter orientation shown in gas metering installation)*

9. Fit bolts diametrically opposite those fitted in step 5 and evenly tighten all bolts hand-tight.
10. Referring to Fig. 2.6, rotate the centralizing tool to push the bolts against the outer edge of the bolt holes.
11. Fit the remaining bolts and hand-tighten evenly.
12. Determine the maximum tightening torque according to the relevant flange specifications.
13. Tighten each bolt to the correct torque in a diagonally opposing pattern, firstly to 30% of the maximum torque, then 60% and finally to the maximum torque.

2.4 Remote RTD Installation

When the optional ABB Remote RTD Assembly (or any other RTD assembly) is used, weld a mounting boss to the pipeline at a location 6 diameters downstream of the center line of the OriMaster – see Fig. 2.7. Drill and tap the boss to accommodate the RTD assembly (typically $\frac{3}{4}$ in. NPT for the ABB Remote RTD Assembly).

Alternative RTD assemblies may be used and the installation method modified to suit, but the 6 diameter downstream separation distance between the RTD and the OriMaster must be maintained.

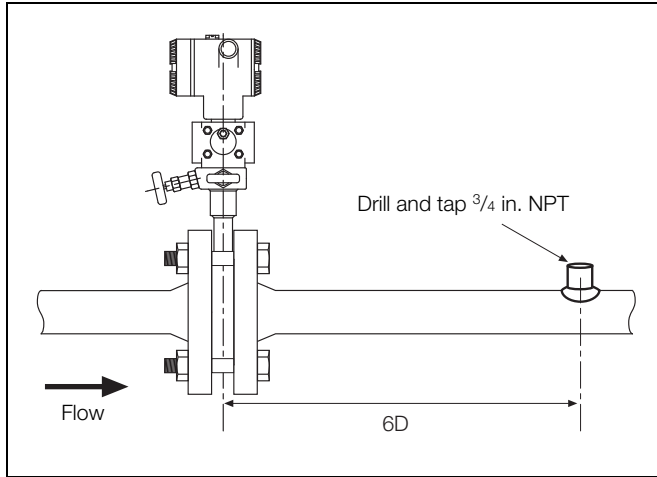

Fig. 2.7 Remote RTD installation

3 Configuration

Note. If the meter has been supplied pre-configured by ABB, do not change parameter settings as this will cause erroneous meter readings.

To configure the OriMaster M, refer to the transmitter Operating Instructions (IM/267C/269C).

4 Commissioning

4.1 Gas and Liquid Service

Caution. During the following procedure, wear Personal Protection Equipment appropriate for the process.

1. Install OriMaster M as described in Section 2.3:
 - for horizontal pipe mounting – gas, refer to Fig. 2.3.
 - for horizontal pipe mounting – liquid, refer to Fig. 2.4.
 - for vertical pipe mounting – liquid or gas, refer to Fig. 2.5.
2. Ensure the pipeline is full.
3. Gradually bring the pipeline up to normal operating pressure, checking for any leaks in the system. If leaks are detected, de-pressurize the pipeline and repair as necessary observing all local health and safety and environmental requirements.
4. When the system is at normal operating pressure and flow established, bleed the OriMaster M impulse lines using the drain/vent valves. Collect and dispose of any bleed liquids in accordance with the local environmental regulations.

Caution. Ensure the drain/vent valves are positioned so that process fluid is directed down and away from personnel when it is removed during the drain/vent operation.

The differential pressure transmitter is normally supplied zeroed at atmospheric conditions (unless otherwise specified). To ensure correct operation, it must be zeroed at the normal operating pressure of the process.

To zero the transmitter:

1. Ensure the pipeline is at the normal operating pressure and that the transmitter power supply is on.
2. Close the high pressure (HP) and low pressure (LP) isolation valves.
3. Open the equalization valve, the transmitter should now indicate a value close to zero.
4. Zero the differential pressure transmitter – refer to the transmitter's Operating Instructions (IM/267C/269C).
5. Open the HP and LP isolation valves.
6. Close the equalization valve. The transmitter should now indicate flow. For information on fault diagnosis, refer to Section 5.1, page 11.

4.2 Steam Service

Note. Fill the impulse lines with water or condensate to ensure correct operation and to protect the transmitter from excessive temperatures.

1. Referring to Fig. 2.4, install OriMaster M as described in Section 2.3.
2. Ensure the process pipeline is empty and de-pressurized.
3. Connect a suitable water supply to the pipeline.
4. Open the drain/vent valves.

Caution. Ensure the drain/vent valves are positioned to direct process fluid down and away from personnel when they are opened during the drain/vent operation.

5. Open the HP and LP isolation valves and allow water to flow **slowly** into the impulse lines until an air-free flow is obtained from the drain/vent valves, indicating that the impulse lines are full.
6. Close the HP and LP isolation valves.
7. Close the drain/vent valves and disconnect the water supply.
8. Gradually bring the pipeline up to normal operating pressure, checking for any leaks in the system. If leaks are detected, de-pressurize the pipeline and repair as necessary observing all local health and safety and environmental requirements.

The differential pressure transmitter is normally supplied zeroed at atmospheric conditions (unless otherwise specified). To ensure correct operation, it must be zeroed at the normal operating pressure of the process.

To zero the transmitter:

1. Ensure the pipeline is at the normal operating pressure and that the transmitter power supply is on.
2. Close the HP and LP isolation valves.
3. Open the manifold equalization valve, the transmitter should now indicate a value close to zero.
4. Zero the differential pressure transmitter – refer to the transmitter's Operating Instructions (IM/267C/269C).
5. Open the HP and LP isolation valves.
6. Close the equalization valve. The transmitter should now indicate flow. For information on fault diagnosis, refer to Section 5.1, page 11.

5 Operation and Maintenance

5.1 Troubleshooting

Refer to the differential pressure transmitter's Operating Instructions (IM/267C/269C) for procedures to be followed when error messages are shown on the transmitter display.

For other suspected problems, complete the following checks to ensure correct installation.

Direction of flow	Ensure the flow direction is in accordance with the arrow on the meter. If not, remove and reinstall the meter correctly.
Mounting orientation	Ensure the meter is correctly oriented to the pipework with regard to flow direction, pipeline and nature of the fluid. Incorrect orientation can lead to metering errors and in some cases may damage the meter.
Zeroing of the transmitter	Zero the differential pressure transmitter during installation and commissioning – see Section 4, page 10.
Manifold valves	The meter manifold is fitted with three valves – two on diametrically opposite sides of the meter (the HP and LP isolation valves) and one on the axis of the pipeline (the equalization valve) During measurement, ensure the equalization valve is fully closed and the HP and LP isolation valves are fully open.
Setup/configuration of the meter	Ensure the 4 to 20 mA output of the meter is correctly set and that any receiving equipment is configured for the same flowrate range. Refer to the differential pressure transmitter's Operating Instructions (IM/267C/269C) for information on how to check the loaded configuration.

Table 5.1 Troubleshooting Checks

5.2 Dismantling

Caution. Neither the transmitter nor the bore of the orifice plate is designed to withstand the weight of the meter. Do not lift the meter by either the orifice plate bore or the transmitter. Lift the meter only by the neck.

Always observe the plant safety regulations. Before beginning work, ensure pipework is depressurized and empty.

To dismantle:

1. If the flanges are fitted with a jacking screw, tighten the screw to remove any free play.
2. Loosen the flange securing bolts and/or nuts and (using the jacking screw, if fitted) partially separate the flanges.
3. Remove sufficient bolts to enable the meter, together with the gaskets, to be lifted clear, ensuring that no part of the meter is damaged.

5.3 Examination

Note.

- The frequency of examination depends upon the abrasive or corrosive nature of the process fluid, for example:
 - Steam – annually
 - Clean fluid – every 2 or 3 years.
- In the case of a new process or plant, examine the meter during each routine maintenance period until the wear of each installation, relative to others, can be assessed.

Examine the meter in accordance with the instructions in Section 2.3, step 4 on page 8.

5.4 Replacing of Removable Plate

1. Remove the OriMaster from the pipeline as per instructions in Section 5.2.
2. Check the removable plate (including the fixings) for damage (as per the criteria of Section 2.3 point 4). If any damage or excess wear is found, it should be replaced.
3. Loosen all 6 fixing screws and remove.
4. Lift the plate out of its location slot.
5. Examine the fixing threads in the OriMaster body checking for damage. If damaged the whole unit should be replaced.
6. Take the new plate out of its protective wrapping and check for damage (again as per the criteria of Section 2.3 point 4).
7. Locate the new plate into the location slot and align the fixing holes with the fixing threads in the OriMaster body.
8. Insert each fixing screw in by hand and loosely tighten.
9. Using a suitably sized screwdriver tighten each fixing screw, working in a diagonally opposing pattern.
10. Check each screw again to ensure they are tight and secure.
11. Reinstall the OriMaster into the pipeline as per Section 5.5.

5.5 Reassembly

Reassemble the meter in accordance with the instructions in Section 2.3, steps 5 to 13 on page 8.

5.6 Remotely Mounted RTD Replacement

To replace the RTD:

1. Ensure the transmitter is powered-down.
2. Remove the transmitter termination cover.
3. Disconnect the RTD wiring from the terminals and remove it from the cable entry.
4. Unscrew the RTD assembly from the thermowell. **DO NOT** remove the thermowell from the pipeline.

Caution. If there is **any** suspicion that process pressure has penetrated the thermowell, *completely depressurize the pipeline before removing the RTD assembly*. Additional precautions relating to the nature of the process fluid may also be required.

5. Screw the replacement RTD assembly into the thermowell.
6. Route the RTD wiring through the cable entry and reconnect to the appropriate terminals – refer to the transmitter Operating Instructions (IM/267C/269C).
7. Power-up the transmitter.

6 Specification – General

Fluids

Liquids, gases and saturated steam

Line sizes

25, 40, 50, 80, 100, 150, 200, 250 and 300 mm
(1, 1½, 2, 3, 4, 6, 8, 10 and 12 in.)

Output signal

- Two-wire, 4 to 20 mA, selected for square-root output
- Low flow cut-off facility
- HART® communication provides digital process variable (% , mA or engineering units) superimposed on 4 to 20 mA signal, with protocol based on Bell202 FSK standard
- Optional Profibus PA, Foundation Fieldbus or Modbus communications (OriMaster M only)

Output current limits (to NAMUR standard)

Overload condition

Lower limit:

- 3.8 mA (configurable from 3.7 to 4 mA)

Upper limit:

- 20.5 mA (configurable from 20 to 22.5 mA)

Alarm current

Minimum alarm current:

- 3.8 mA (configurable from 3.7 to 4 mA)

Maximum alarm current:

- 22 mA (configurable from 20 to 22.5 mA)

Standard setting:

- maximum alarm current

Power supply

- The meter operates from 10.5 to 45 V DC with no load and is protected against reverse polarity connection (additional load allows operations over 45 V DC)
- For EEx ia and other intrinsically safe approvals, the power supply must not exceed 30 V DC. Minimum operating voltage is 14 V DC with backlit display.

Load limitations

- $R(k) = \frac{\text{Supply voltage} - \text{min. operating voltage (V DC)}}{22.5}$
- A minimum of 250 is required for HART communication

Optional indicators

Integral display

2-line, 6-character, 19-segment alphanumeric display with additional bar-chart display. Back illumination optional. User-specific display, percentage of the output current, output current in mA or process variable. Diagnostic messages, alarms, measuring range infringements and changes in the configuration are also displayed.

Wetted materials

Orifice assembly, stem and manifold

316L stainless steel

Transmitter sensor housing

OriMaster M:

- Aluminum alloy
(316L stainless steel optional)

Process isolating diaphragms

Hastelloy C276 (NACE)

Seals

Transmitter to manifold:

- PTFE

Manifold:

- Graphite; PTFE

Process connections

Wafer body to fit between the following flange drillings

- ASME B16.5 (ANSI) Class 150, 300 or 600
- DIN PN16, PN25, PN40 or PN100

Pipeline centralization assured by centralizing tool(s) supplied with every unit as standard

Pressure limitations

100 bar (1450 psi) or as flange rating, whichever is the lower

Temperature limitations

Process

- -20 to 121 °C (-4 to 250 °F)
- -20 to 230 °C (-4 to 446 °F) for steam applications

Ambient

-20 to 70 °C (-4 to 158 °F)

Orifice plate bore at 20 °C (68 °F):

For Beta = 0.4

- 25 mm (1 in.)10.66 mm (0.42 in.)
- 40 mm (1½ in.)16.36 mm (0.644 in.)
- 50 mm (2 in.)20.99 mm (0.826 in.)
- 80 mm (3 in.)31.17 mm (1.227 in.)
- 100 mm (4 in.)40.90 mm (1.610 in.)
- 150 mm (6 in.)61.63 mm (2.426 in.)
- 200 mm (8 in.)81.10 mm (3.193 in.)
- 250 mm (10 in.)101.8 mm (4.008 in.)
- 300 mm (12 in.)121.29 mm (4.775 in.)

For Beta = 0.65

- 25 mm (1 in.)17.32 mm (0.682 in.)
- 40 mm (1½ in.)26.58 mm (1.047 in.)
- 50 mm (2 in.)34.11 mm (1.343 in.)
- 80 mm (3 in.)50.65 mm (1.994 in.)
- 100 mm (4 in.)66.47 mm (2.617 in.)
- 150 mm (6 in.)100.15 mm (3.942 in.)
- 200 mm (8 in.)131.78mm (5.188 in.)
- 250 mm (10 in.)165.43 mm (4.01 in.)
- 300 mm (12 in.)197.1 mm (7.76 in.)

Weight in kg (lb) (approximately)

Size	Typical Weight
25 mm (1 in.)	9.5 (21)
40 mm (1½ in.)	10 (22)
50 mm (2 in.)	10.5 (23)
80 mm (3 in.)	11.5 (25.3)
100 mm (4 in.)	12 (26.5)
150 mm (6 in.)	14 (31)
200 mm (8 in.)	16 (35.3)
250 mm (10 in.)	19 (42)
300 mm (12 in.)	21.5 (47.4)

Upstream straight pipe requirements to ISO 5167:2003

Fitting	$\beta = 0.4$	$\beta = 0.65$
Conical reducer (2D – D)	5D	12D
Conical expander (0.5D – D)	12D	28D
Single 90 ° bend	16D	44D
2 off 90 ° bends in same plane	10D	44D
2 off 90 ° bends in different plane	50D	60D

Where D = pipe diameter

Vibration limits to IEC60068-2-6

Maximum pipe vibration level

<0.5g over frequency range 10 to 500Hz

Performance

System accuracy at reference conditions (for Re >10⁵)

Uncalibrated

Model	Beta	% Vol. flow rate		% Mass-flow rate	
		Size in mm (in.)			
		25 to 40 (1 to 1½)	50 to 200 (2 to 8)	25 to 40 (1 to 1½)	50 to 200 (2 to 8)
OriMaster M	0.4			2	1.5
	0.65 *			2	1.5

* For a combination of Re <10⁵ and Beta = 0.65, add 0.5 %

Calibrated

ABB standard water calibration (3 points over a 5:1 flow range)

System accuracy:

- ± 1 % of flowrate

Repeatability

OriMaster M:

- 0.1 %

Turndown

OriMaster M:

- up to 8:1

7 Specification

Range and span limits

Sensor code	Upper range limit (URL)	Minimum span
C	6 kPa	0.2 kPa
	60 mbar	2 mbar
	24 in. H ₂ O	0.8 in. H ₂ O
F	40 kPa	0.4 kPa
	400 mbar	4 mbar
	160 in. H ₂ O	1.6 in. H ₂ O
L	250 kPa	2.5 kPa
	2500 mbar	25 mbar
	1000 in. H ₂ O	10 in. H ₂ O

Temperature limits

Ambient

Silicone oil filling:

- -40 to 85 °C (-40 to 185 °F)

LCD display:

- -20 to 70 °C (-4 to 158 °F)

Lower ambient limit for Viton and PTFE gaskets: -20 °C (-4 °F)

Note. For Hazardous Atmosphere applications refer to the temperature range specified on the certificate/approval relevant to the required type of protection

Process

Lower limit:

- refer to lower ambient limits

Upper limit (silicone oil):

- 121 °C (250 °F) for working pressure above 10 kPa abs., 100 mbar abs., 1.45 psia

Storage

Lower limit:

85°C (185 °F)

Upper limit:

- -50 °C (-58 °F)
- -40 °C (-40 °F) for LCD indicator

Temperature element

Integral

- 100 Ω Platinum RTD, cabled directly to the transmitter

Remote (where supplied by ABB):

Element:

- 100 Ω Platinum RTD

Cable:

- 4-core screened, PTFE

Thermowell:

- 3/4 in. NPT screwed pocket in 316L stainless steel

Hazardous Atmospheres – ATEX according to Directive 94/9/EC – ordering code EW

Transmitter of protection type 'Intrinsically safe EEx ia', 'Flameproof enclosure EEx d', Limited energy equipment EEx nL'

Transmitter with 4 to 20 mA output signal and HART communication

Identification:

- II 1/2 GD T50 °C EEx ia IIC T6

OR

Identification:

- II 1/2 GD T85 °C EEx d IIC T6

Ambient temperature range:

- -40 to 75 °C (-40 to 167 °F)

OR

Identification

- II 3 GD T50 °C EEx nL IIC T6
- II 3 GD T95 °C EEx nL IIC T4 (refer to 'EEx ia' for additional data)

**Hazardous Atmospheres – Factory Mutual (FM)
Intrinsically Safe – ordering code EA**

Transmitter with 4 to 20 mA output signal and HART communication

Intrinsically safe:

- Class I; Division 1; Groups A, B, C, D
- Class I; Zone 0; Group IIC; AEx ia IIC

Degree of protection:

- NEMA Type 4X (indoor or outdoor)

Maximum permissible ambient temperatures depending on the temperature class:

U _{max} = 30 V, C _i = 10.5 nF, L _i = 10 µH			
Ambient temperature	Temperature class	I _{max}	P _i
-40 to 85 °C (-40 to 185 °F)	T4	200 mA	0.8 W
-40 to 70 °C (-40 to 158 °F)			1 W
-40 to 40 °C (-40 to 104 °F)	T5	25 mA	0.75 W
	T6		0.5 W

**Fieldbus transmitters
(PROFIBUS PA/FOUNDATION Fieldbus)**

Intrinsically safe:

- Class I, II and III; Division 1; Groups A, B, C, D, E, F, G
- Class I; Zone 0; AEx ia Group IIC T6, T4;
Non-incendive Class I, II and III; Division 2;
Groups A, B, C, D, E, F, G

**Hazardous Atmospheres – Factory Mutual (FM)
Explosion Proof – ordering code EB**

**Transmitters with 4 to 20 mA output signal and
HART communication and Fieldbus transmitter
(PROFIBUS PA/ FOUNDATION Fieldbus)**

Explosion proof:

- Class I; Division 1; Groups A, B, C, D
- Class II/III; Division 1; Groups E, F, G

Degree of protection:

- NEMA Type 4X (indoor or outdoor)

**Hazardous Atmospheres – Canadian standard (CSA) –
ordering code EE**

**Transmitter with 4 to 20 mA output signal and
HART communication and Fieldbus transmitter
(PROFIBUS PA/FOUNDATION Fieldbus)**

Explosion proof:

- Class I; Division 1; Groups B, C, D
- Class IIC/III; Division 1; Groups E, F, G

Degree of protection:

- NEMA Type 4X (indoor or outdoor)

DS/FPD500-EN Rev. D

Products and customer support

Automation Systems

For the following industries:

- Chemical & Pharmaceutical
- Food & Beverage
- Manufacturing
- Metals and Minerals
- Oil, Gas & Petrochemical
- Pulp and Paper

Drives and Motors

- AC and DC Drives, AC and DC Machines, AC Motors to 1kV
- Drive Systems
- Force Measurement
- Servo Drives

Controllers & Recorders

- Single and Multi-loop Controllers
- Circular Chart and Strip Chart Recorders
- Paperless Recorders
- Process Indicators

Flexible Automation

- Industrial Robots and Robot Systems

Flow Measurement

- Electromagnetic Flowmeters
- Mass Flowmeters
- Turbine Flowmeters
- Wedge Flow Elements

Marine Systems & Turbochargers

- Electrical Systems
- Marine Equipment
- Offshore Retrofit and Refurbishment

Process Analytics

- Process Gas Analysis
- Systems Integration

Transmitters

- Pressure
- Temperature
- Level
- Interface Modules

Valves, Actuators and Positioners

- Control Valves
- Actuators
- Positioners

Water, Gas & Industrial Analytics Instrumentation

- pH, Conductivity and Dissolved Oxygen Transmitters and Sensors
- Ammonia, Nitrate, Phosphate, Silica, Sodium, Chloride, Fluoride, Dissolved Oxygen and Hydrazine Analyzers
- Zirconia Oxygen Analyzers, Katharometers, Hydrogen Purity and Purge-gas Monitors, Thermal Conductivity

Customer support

We provide a comprehensive after sales service via a Worldwide Service Organization. Contact one of the following offices for details on your nearest Service and Repair Centre.

UK

ABB Limited

Tel: +44 (0)1946 830 611

Fax: +44 (0)1946 832 661

USA

ABB Inc.

Tel: +1 215 674 6000

Fax: +1 215 674 7183

Client Warranty

Prior to installation, the equipment referred to in this manual must be stored in a clean, dry environment, in accordance with the Company's published specification. Periodic checks must be made on the equipment's condition. In the event of a failure under warranty, the following documentation must be provided as substantiation:

- A listing evidencing process operation and alarm logs at time of failure.
- Copies of all storage, installation, operating and maintenance records relating to the alleged faulty unit.

Contact us

ABB Limited

Process Automation

Salterbeck Trading Estate
Workington, Cumbria
CA14 5DS
UK

Tel: +44 (0)1946 830 611

Fax: +44 (0)1946 832 661

ABB Inc.

Process Automation

125 E. County Line Road
Warminster
PA 18974
USA

Tel: +1 215 674 6000

Fax: +1 215 674 7183

www.abb.com

Note

We reserve the right to make technical changes or modify the contents of this document without prior notice. With regard to purchase orders, the agreed particulars shall prevail. ABB does not accept any responsibility whatsoever for potential errors or possible lack of information in this document.

We reserve all rights in this document and in the subject matter and illustrations contained therein. Any reproduction, disclosure to third parties or utilization of its contents in whole or in parts – is forbidden without prior written consent of ABB.

Copyright© 2011 ABB

All rights reserved