

ABB MEASUREMENT & ANALYTICS | DATA SHEET

TTH300

Head-mount temperature transmitter



Measurement made easy

Temperature transmitter for all communications protocols.

Redundancy thanks to two inputs

Reliable temperature measurement for the highest demands

- High accuracy, reliability and durability
- Specific sensor linearization via Callendar-Van Dusen coefficients and with value pair table (32 points)
- Suited for ambient temperatures from -50 °C (-58 °F)

Input circuit and communication

- Two universal sensor inputs for resistance thermometers (e.g. $2 \times \text{Pt}100$ in three-wire circuit) and thermocouples
- 4 to 20 mA, HART[®], PROFIBUS PA[®], FOUNDATION Fieldbus[®]

Safety

- Global approvals for explosion protection up to Zone 0
- Functional safety SIL 2 / SIL 3 in accordance with IEC 61508 (HART)
- Device versioning in accordance with NE 53
- Monitoring of the 4 to 20 mA loop current
- Wire break / corrosion monitoring in accordance with NE 89
- Sensor drift monitoring
- Device status signaling and freely configurable diagnostic categorization with diagnostic history according to NE 107

Configuration and tracking

- Support of DTM, EDD and FDI standard (FIM)
- Event monitor for the logging of critical events
- Configuration monitor for configuration changes
- Turnable LCD indicator with operating buttons

Specification

CE Marking

The device fulfills all requirements for CE marking in accordance with all applicable guidelines.

Electrical isolation

3.5 kV DC (approx. 2.5 kV AC), 60 s, input to output

Input filter

50 / 60 Hz

Switch-on delay

- HART:< 10 s ($I_a \leq 3.6$ mA during switch-on cycle)
- PROFIBUS:10 s, max. 30 s
- FOUNDATION Fieldbus:< 10 s

Warm-up time

5 minutes

Rise time t_{90}

400 to 1000 ms

Measured value update

10/s with 1 sensor, 5/s with 2 sensors, depending on sensor type and sensor circuit

Output filter

Digital filter 1st order:0 to 100 s

Weight

50 g

Material

- Housing: Polycarbonate
- Color: gray RAL9002
- Casting compound: Polyurethane (PUR)

Installation conditions

- Mounting position: no restrictions
- Installation options:
 - Connection heads in accordance with DIN 43729 form B
 - Rail mounting (35 mm) in accordance with EN 60175 by means of latching base
 - Field mount housing

Electrical connection

- Terminals with captive stainless steel screws, including soldering tags
- Lines up to a maximum of 1.5 mm² (AWG 16)
- Connection for handheld terminal

Dimensions

See chapter **Dimensions** on page 18.

Ambient conditions

Ambient temperature

- Standard: -40 to 85 °C (-40 to 185 °F)
- Optional: -50 to 85 °C (-58 to 185 °F)
- Restricted range with hazardous area design: see relevant certificate

Transport- / Storage temperature

-50 to 85 °C (-58 to 185 °F)

Climate class in accordance with DIN EN 60654-1

Cx -40 to 85 °C (-40 to 185 °F) at 5 to 95 % relative air humidity

Max. permissible humidity in accordance with IEC 60068-2-30

100 % relative air humidity

Vibration resistance in accordance with IEC 60068-2-6

10 to 2000 Hz at 5 g, during operation and transport

Shock resistance in accordance with IEC 60068-2-27

$g_n = 30$, during operation and transport

IP rating

- Power supply circuit: IP 20
- Measurement current circuit: IP 00 or IP-rating of installation housing

... Specification

Electromagnetic compatibility

Emitted interference and interference immunity in accordance with IEC EN 61326-1 and NAMUR NE 21. The extended requirements in accordance with IEC EN 61326-3-2 are met for HART® communication from HW rev. 02.00.

Sensor for tests:

Pt100, measuring range 0 to 100 °C (32 to 212 °F), span 100 K

Type of test	Testing accuracy	Effect
Burst to signal- / data lines	2 kV	< 0,5 %
Static discharge*		
• Air discharge	8 kV	No
• Contact discharge	6 kV	No
radiated field, IEC EN 61326-1 and NAMUR NE 21:		
80 MHz to 2.7 GHz	10 V/m	< 0,5 %
2.7 GHz to 6 GHz	3 V/m	< 0,5 %
Coupling		
10 kHz to 80 MHz**	10 V	< 0,5 %
150 kHz to 80 MHz	10 V	< 0,5 %
Surge voltage / line to ground	1 kV	B*

* Assessment criterion B in accordance with IEC EN 61326-1 and NAMUR NE 21

** For HART® communication from HW rev. 02.00

SIL functional safety

Only for devices with HART communication.

With certificate* in accordance with IEC 61508 for the use in safety-relevant applications up to and including SIL 3 (redundant).

- In the use of one transmitter the device fulfills the requirements according to SIL 2.
- In the use of redundant handled transmitters the requirements can be fulfilled according to SIL 3.

Detailed information can be found in the SIL-Safety Manual.

* From HW rev. 02.00.02, previously Declaration of Conformity.

Type A and type AS LCD indicators

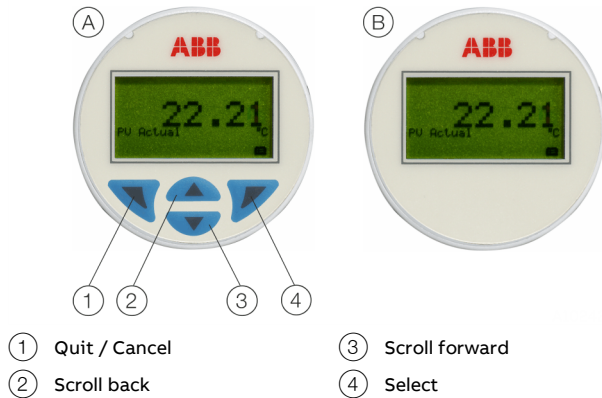

Figure 1: (A) LCD indicator Type A (B) LCD indicator Type AS

The LCD indicator type AS has a display function; the LCD indicator type A allows additional configuration functions to be carried out.

Both LCD indicators can only be ordered in conjunction with temperature transmitter.

CE-Marking

The LCD indicator type A and type AS fulfill all requirements for CE marking in accordance with all applicable guidelines.

Properties

Transmitter-controlled graphic (alphanumeric) LCD indicator

- Character height, mode-dependent
- Sign, 4 digits, 2 decimal places
- Bargraph display
- Turnable in 12 increments of 30° each

Display options

- Sensor 1 process value
- Sensor 2 process value
- Electronics- / ambient temperature
- Output value
- Output %

Display diagnostic information related to transmitter and sensor status

HART devices from SW rev. 03.00 (corresponds to HW rev. 02.00 and higher)

- Display of either one or two process values
- Advanced diagnostics: Error display in plain text with possible shutdown measures. Display of multiple simultaneous diagnoses.

Specification

Temperature range

-40 to 85 °C (-40 to 185 °F)

Restricted display function (contrast, reaction time) in the temperature ranges:

- -50 to -20 °C (-58 to -4 °F) or
- 70 to 85 °C (158 to 185 °F)

Air humidity

0 to 100 %, condensation permitted

Configuration function

- Sensor configuration for standard sensors
- Measuring range
- Behavior in the event of a fault (HART)
- Software write protection for configuration data
- Device address for HART and PROFIBUS PA

... Specification

Input - resistance thermometer / resistances

Resistance thermometer

- Pt100 in accordance with IEC 60751, JIS C1604, MIL-T-24388
- Ni in accordance with DIN 43760
- Cu in accordance with recommendation OIML R 84

Resistance measurement

- 0 to 500 Ω
- 0 to 5000 Ω

Sensor connection type

Two-, three-, four-wire circuit

Connection lead

- Maximum sensor line resistance per line 50 Ω in accordance with NE 89
- Three-wire circuit:
Symmetrical sensor line resistances
- Two-wire circuit:
Compensation up to 100 Ω total lead resistance

Measurement current

< 300 μ A

Sensor short circuit

< 5 Ω (for resistance thermometer)

Sensor wire break

- Measuring range: 0 to 500 Ω > 0.6 to 10 k Ω
- Measuring range: 0 to 5 Ω > 5.3 to 10 k Ω

Detection of sensor wire break in accordance with NE 89 in all lines

Sensor error signaling

- Resistance thermometer:
Sensor short circuit and sensor wire break
- Linear resistance measurement:
Sensor wire break

Input - thermocouples / voltages

Types

- B, E, J, K, N, R, S, T in accordance with IEC 60584
- U, L in accordance with DIN 43710
- C in accordance with IEC 60584 / ASTM E988
- D in accordance with ASTM E988

Voltages

- -125 to 125 mV
- -125 to 1100 mV

Connection lead

- Maximum sensor line resistance:
per line 1.5 k Ω , total 3 k Ω

Detection of sensor wire break in accordance with NE 89 in all lines

Input resistance

> 10 M Ω

Internal reference junction Pt1000, IEC 60751 Cl. B

(no additional jumpers necessary)

Sensor error signaling

- Thermocouple:
Sensor wire break
- Linear voltage measurement:
Sensor wire break

Functionality input

Freestyle characteristic / 32-points-sampling point table

- Resistance measurement up to a maximum of 5 k Ω
- Voltages up to maximum 1.1 V

Sensor error adjustment

- Through Callendar-Van Dusen coefficients
- Through value table, 32 support points
- Through single-point adjustment (offset adjustment)
- Through two-point adjustment

Input functionality

- 1 Sensor
- 2 Sensors:
mean measurement,
differential measurement,
sensor redundancy,
Sensor drift monitoring

HART® output

Transmission behavior

- Temperature linear
- Resistance linear
- Voltage linear

Output signal

- Configurable 4 to 20 mA (standard)
- Configurable 20 to 4 mA
(dynamic range: 3.8 to 20.5 mA in accordance with NE 43)

Simulation mode

3.5 to 23.6 mA

Induced current consumption

< 3.5 mA

Maximum output current

23.6 mA

Configurable error current signal

Note

Regardless of the alarm setting (underrange or overrange), a high alarm or low alarm is always generated for some internal device errors (e.g. hardware errors). Detailed information about this can be found in the SIL-Safety Manual.

Notice – Before SW rev. 03.00

The default factory setting for the error current signal is high alarm 22 mA.

- Overrange / high alarm 22 mA (20.0 to 23.6 mA)
- Underrange / low alarm 3.6 mA (3.5 to 4.0 mA)

Notice – From SW rev. 03.00

The default factory setting for the error current signal is low alarm 3.5 mA, in accordance with NAMUR recommendations NE 93, NE 107 and NE 131.

- Overrange / high alarm 22 mA (20.0 to 23.6 mA)
- Underrange / low alarm 3.5 mA (3.5 to 4.0 mA)

PROFIBUS PA® output

Output signal

- PROFIBUS – MBP (IEC 61158-2)
- Baud rate 31.25 kBit/s
- PA-Profile 3.01
- FISCO compliant (IEC 60079-27)
- ID-Number: 0x3470 [0x9700]

Error current signal

- FDE (Fault Disconnection Electronic)

Block structure

- Physical Block
- Transducer Block 1 – Temperature
- Transducer Block 2 – HMI (LCD indicator)
- Transducer Block 3 – enhanced diagnosis
- Analog Input 1 – Primary Value (Calculated Value*)
- Analog Input 2 – SECONDARY VALUE_1 (Sensor 1)
- Analog Input 3 – SECONDARY VALUE_2 (Sensor 2)
- Analog Input 4 – SECONDARY VALUE_3 (reference junction temperature)
- Analog Output – optional HMI display (Transducer Block 2)
- Discrete Input 1 – extended diagnosis 1 (Transducer Block 3)
- Discrete Input 2 – extended diagnosis 2 (Transducer Block 3)

- * Sensor 1, Sensor 2 or difference or mean

For detailed information see the PROFIBUS PA® interface description (COM/TTX300/PB).

... Specification

FOUNDATION Fieldbus® output

Output signal

- FOUNDATION Fieldbus H1 (IEC 611582-2)
- Baud rate 31.25 kBit/s, ITK 5.x
- FISCO compliant (IEC 60079-27)
- Device ID:000320001F...

Error current signal

- FDE (Fault Disconnection Electronic)

Block structure*

- Resource Block
- Transducer Block 1 – Temperature
- Transducer Block 2 – HMI (LCD indicator)
- Transducer Block 3 – enhanced diagnosis
- Analog Input 1 – PRIMARY_VALUE_1 (Sensor 1)
- Analog Input 2 – PRIMARY_VALUE_2 (Sensor 2)
- Analog Input 3 – PRIMARY_VALUE_3 (Calculated Value**)
- Analog Input 4 – SECONDARY_VALUE (reference junction temperature)
- Analog Output – optional HMI display (Transducer Block 2)
- Discrete Input 1 – extended diagnosis 1 (Transducer Block 3)
- Discrete Input 2 – extended diagnosis 2 (Transducer Block 3)
- PID – PID controller

LAS (Link Active Scheduler) link master functionality

* For the block description, block index, execution times, and block class, refer to the interface description

** Sensor 1, Sensor 2 or difference or mean

For detailed information, see the COM/TTX300/FF FOUNDATION Fieldbus® interface description.

Power supply

Two-wire technology, polarity safe; power supply lines = signal lines

Note

Following calculations apply for standard applications. This should be taken into consideration when working with a higher maximum current.

Power supply – HART®

Supply voltage

- Non-Ex application:
 $U_S = 11$ to 42 V DC
- Ex applications:
 $U_S = 11$ to 30 V DC

Maximum permissible residual ripple for supply voltage

During communication this complies with the HART FSK 'Physical Layer' specification.

Undervoltage detection on the transmitter

If the terminal voltage on the transmitter down-scales a value of 10 V, this may lead to an output current of $I_a \leq 3.6$ mA.

Maximum load

$$R_B = (\text{supply voltage} - 11 \text{ V}) / 0.022 \text{ A}$$

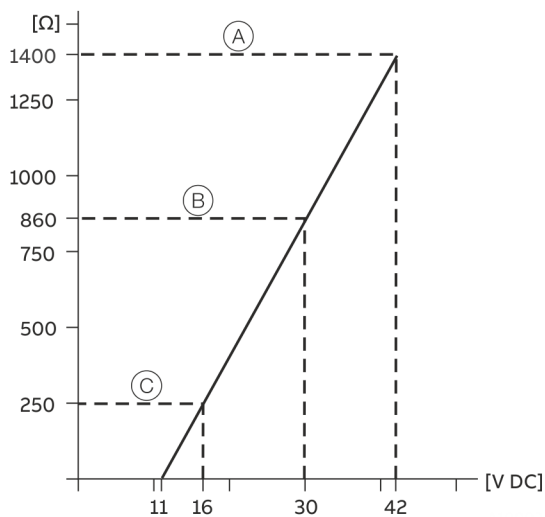

- (A) TTH300
 (B) TTH300 in Ex-applications
 (C) HART communication resistance

Figure 2: Maximum load depending on supply voltage

Maximum power

$$P = U_S \times 0.022 \text{ A}$$

$$\text{E. G.: } U_S = 24 \text{ V} \rightarrow P_{\text{max}} = 0.528 \text{ W}$$

Power supply – PROFIBUS® / FOUNDATION Fieldbus®

Supply voltage

- Non-Ex application:
 $U_S = 9$ to 32 V DC
- Ex-applications:
 $U_S = 9$ to $17,5$ V DC (FISCO)
 $U_S = 9$ to 24 V DC (Fieldbus Entity model I.S.)

Current consumption

$$\leq 12 \text{ mA}$$

... Specification

Measuring accuracy

Includes linearity error, repeatability / hysteresis at 23 °C (73.4 °F) ± 5 K and 20 V supply voltage.

Information on measuring accuracy corresponds to 3 σ (Gaussian distribution).

Long-term drift: ±0.05 °C (±0.09 °F) or ±0.05 %* per year, the larger value applies.

Sensor	Measurement range limits	Minimum span	Measuring accuracy		
			Input (24-bit AD-converter)	Analog output* (16-Bit D / A-converter)	
Resistance thermometer / resistor					
DIN IEC 60751	Pt10 (a=0.003850)	-200 to 850 °C (-328 to 1562 °F)	10 °C (18 °F)	±0.80 °C (±1.44 °F)	±0.05%
	Pt50 (a=0.003850)			±0.16 °C (±0.29 °F)	±0.05%
	Pt100 (a=0.003850)**			±0.08 °C (±0.14 °F)	±0.05%
	Pt200 (a=0.003850)			±0.40 °C (±0.72 °F)	±0.05%
	Pt500 (a=0.003850)			±0.16 °C (±0.29 °F)	±0.05%
	Pt1000 (a=0.003850)			±0.08 °C (±0.14 °F)	±0.05%
JIS C1604	Pt10 (a=0.003916)	-200 to 645 °C (-328 to 1193 °F)	10 °C (18 °F)	±0.80 °C (±1.44 °F)	±0.05%
	Pt50 (a=0.003916)			±0.16 °C (±0.29 °F)	±0.05%
	Pt100 (a=0.003916)			±0.08 °C (±0.14 °F)	±0.05%
MIL-T-24388	Pt10 (a=0.003920)	-200 to 850 °C (-328 to 1562 °F)	10 °C (18 °F)	±0.80 °C (±1.44 °F)	±0.05%
	Pt50 (a=0.003920)			±0.16 °C (±0.29 °F)	±0.05%
	Pt100 (a=0.003920)			±0.08 °C (±0.14 °F)	±0.05%
	Pt200 (a=0.003920)			±0.40 °C (±0.72 °F)	±0.05%
	Pt1000 (a=0.003920)			±0.08 °C (±0.14 °F)	±0.05%
DIN 43760	Ni50 (a=0.006180)	-60 to 250 °C (-76 to 482 °F)	10 °C (18 °F)	±0.16 °C (±0.29 °F)	±0.05%
	Ni100 (a=0.006180)			±0.08 °C (±0.14 °F)	±0.05%
	Ni120 (a=0.006180)				±0.05%
	Ni1000 (a=0.006180)				±0.05%
OIML R 84	Cu10 (a=0.004270)	-50 to 200 °C (-58 to 392 °F)	10 °C (18 °F)	±0.80 °C (±1.44 °F)	±0.05%
	Cu100 (a=0.004270)			±0.08 °C (±0.14 °F)	±0.05%
	Resistance measurement	0 to 500 Ω	4 Ω	±32 m Ω	±0.05%
		0 to 5000 Ω	40 Ω	±320 m Ω	±0.05%

* Percentages refer to the configured measuring span, omitted for PROFIBUS PA® and FOUNDATION Fieldbus®

** Standard Version

Sensor	Measurement range limits	Minimum span	Measuring accuracy		
			Input* (24-bit AD-converter)	Analog output** (16-Bit D / A-converter)	
Thermocouples*** / voltages					
IEC 60584	Type K (Ni10Cr-Ni5)	-200 to 1372 °C (-328 to 2502 °F)	50 °C (90 °F)	±0.35 °C (±0.63 °F)	±0.05%
	Type J (Fe-Cu45Ni)	-210 to 1200 °C (-346 to 2192 °F)			±0.05%
	Type N (Ni14CrSi-NiSi)	-200 to 1300 °C (-328 to 2372 °F)			±0.05%
	Type T (Cu-Cu45Ni)	-200 to 400 °C (-328 to 752 °F)			±0.05%
	Type E (Ni10Cr-Cu45Ni)	-200 to 1000 °C (-328 to 1832 °F)			±0.05%
	Type R (Pt13Rh-Pt)	-50 to 1768 °C (-58 to 3215 °F)	100 °C (180 °F)	±0.95 °C (±1.71 °F)	±0.05%
	Type S (Pt10Rh-Pt)			±1.15 °C (±2.07 °F)	±0.05%
	Type B (Pt30Rh-Pt6Rh)	250 to 1820 °C (482 to 3308 °F)		±1.05 °C (±1.89 °F)	±0.05%
DIN 43710	Type L (Fe-CuNi)	-200 to 900 °C (-328 to 1652 °F)	50 °C (90 °F)	±0.35 °C (±0.63 °F)	±0.05%
	Type U (Cu-CuNi)	-200 to 600 °C (-328 to 1112 °F)			±0.05%
IEC 60584 / ASTM E988	Type C	0 to 2315 °C (32 to 4200 °F)	100 °C (180 °F)	±1.35 °C (±2.43 °F)	±0.05%
ASTM E988	Type D				±0.05%
	Voltage measurement	-125 to 125 mV	2 mV	±12 µV	±0.05%
		-125 to 1100 mV	20 mV	±120 µV	±0.05%

* Due to the physical properties of thermocouples, the accuracy of temperature measurement decreases at low temperatures and may then be outside the specified accuracy range at the input. The specified accuracy applies to

Type K: > -60 °C, type J: > -140 °C, type N: >250 °C, type T: > -40 °C, type E: > -150 °C,

Type R: >860 °C (400 to 860 °C: ±1.15 °C), type S: >650 °C (250 to 650 °C: ±1.36 °C),

Type B: >1440 °C (500 to <1000 °C: ±2.4 °C, 1000 to 1440 °C: ±1.32 °C)

Type L: > -140 °C (≤ -140 °C: ±0.41 °C), type U: > -40 °C (≤ -40 °C: ±0.63 °C),

Type C and type D: no restriction

Type K: > -76 °F, type J: > -220 °F, type N: >482 °F, type T: > -40 °F, type E: > -238 °F,

Type R: >1580 °F (752 to 1580 °F: ±2.07 °F), type S: >1202 °F (482 to 1202 °F: ±2.45 °F),

Type B: >2624 °F (932 to <1832 °F: ±4.32 °F, 1832 to 2624 °F: ±2.38 °F)

Type L: > -220 °F (≤ -220 °F: ±0.74 °F), type U: > -40 °F (≤ -40 °F: ±1.13 °F),

** Percentages refer to the configured measuring span, omitted for PROFIBUS PA® and FOUNDATION Fieldbus®

*** For digital measuring accuracy, the internal reference junction error must be added: Pt1000, DIN IEC 60751 Cl. B

... Specification

Operating influence

The percentages refer to the configured measuring span.

Supply voltage effect / load effect:

Within the specified limit values for the voltage / load, the total influence is less than 0.001 % per volt.

Common-mode interference

No influence up to 100 V_{eff} (50 Hz) or 50 VDC

Ambient temperature influence:

Based on 23 °C (73.4 °F) for an ambient temperature range of -40 to 85 °C (-40 to 185 °F)¹

Sensor		Ambient temperature effect per 1 °C (1.8 °F) deviation from 23 °C (73.4 °F)	
		Input ² (24-bit A / D converter)	Analog output ^{3, 4} (16 bit DA-converter)
Resistance thermometer for two-, three- and four-wire circuits			
IEC, JIS, MIL	Pt10	±0,04 °C (±0.072 °F)	±0.003%
	Pt50	±0.008 °C (±0.014 °F)	±0.003%
	Pt100	±0.004 °C (±0.007 °F)	±0.003%
IEC, MIL	Pt200	±0.02 °C (±0.036 °F)	±0.003%
	Pt500	±0.008 °C (±0.014 °F)	±0.003%
	Pt1000	±0.004 °C (±0.007 °F)	±0.003%
DIN 43760	Ni50	±0.008 °C (±0.014 °F)	±0.003%
	Ni100	±0.004 °C (±0.007 °F)	±0.003%
	Ni120	± 0.003 °C (± 0.005 °F)	±0.003%
	Ni1000	±0.004 °C (±0.007 °F)	±0.003%
OIML R 84	Cu10	±0,04 °C (±0.072 °F)	±0.003%
	Cu100	±0.004 °C (±0.007 °F)	±0.003%
Resistance measurement			
	0 to 500 Ω	±0.002 Ω	±0.003%
	0 to 5000 Ω	±0.02 Ω	±0.003%
Thermocouple, for all defined types			
		± [(0.001 % × (ME[mV] / MS[mV]) + (100 % × (0.009 °C / MS [°C]))] ⁵	±0.003%
Voltage measurement			
	-125 to 125 mV	±1.5 μV	±0.003%
	-125 to 1100 mV	±15 μV	±0.003%

1 For the optionally extended ambient temperature range down to -50 °C (-58 °F), twice the influence values apply in the range from -50 to -40 °C (-58 to -40 °F)

2 Typical values

3 Percentages refer to the configured measuring span of the analog output signal

4 Influence D / A converter not applicable for PROFIBUS PA® and FOUNDATION Fieldbus®

5 Percentages refer to the configured measuring span

ME = voltage value of the thermocouple at the upper range value in accordance with the standard

MA = voltage value of the thermocouple at the lower range value in accordance with the standard

MS = voltage value of the thermocouple over the measuring span in accordance with the standard. MS = (ME - MA)

Electrical connections

Terminal assignment

Resistance thermometers (RTD) / resistors (potentiometer)

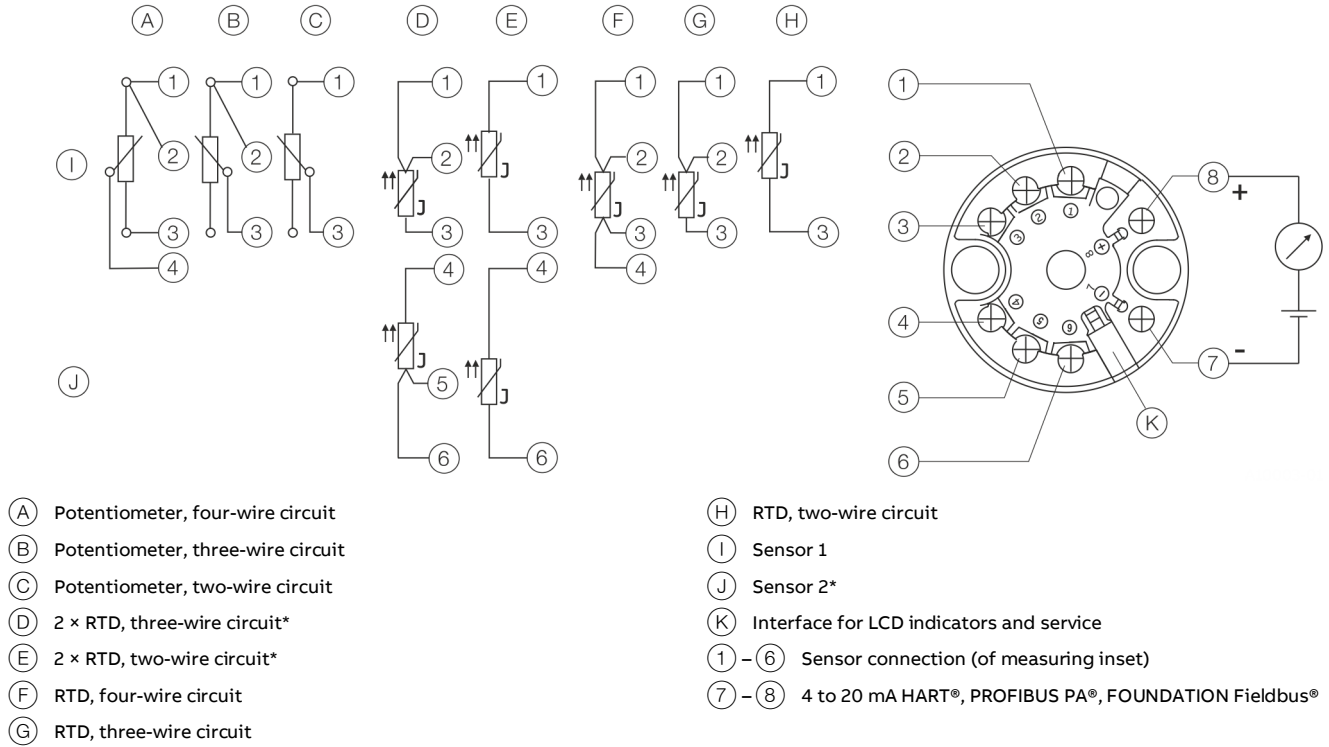

Figure 3: Terminal assignment for resistance thermometers (RTD) / resistors (potentiometers)

... Electrical connections

Thermocouples / voltages and resistance thermometers (RTD) / thermocouple combinations

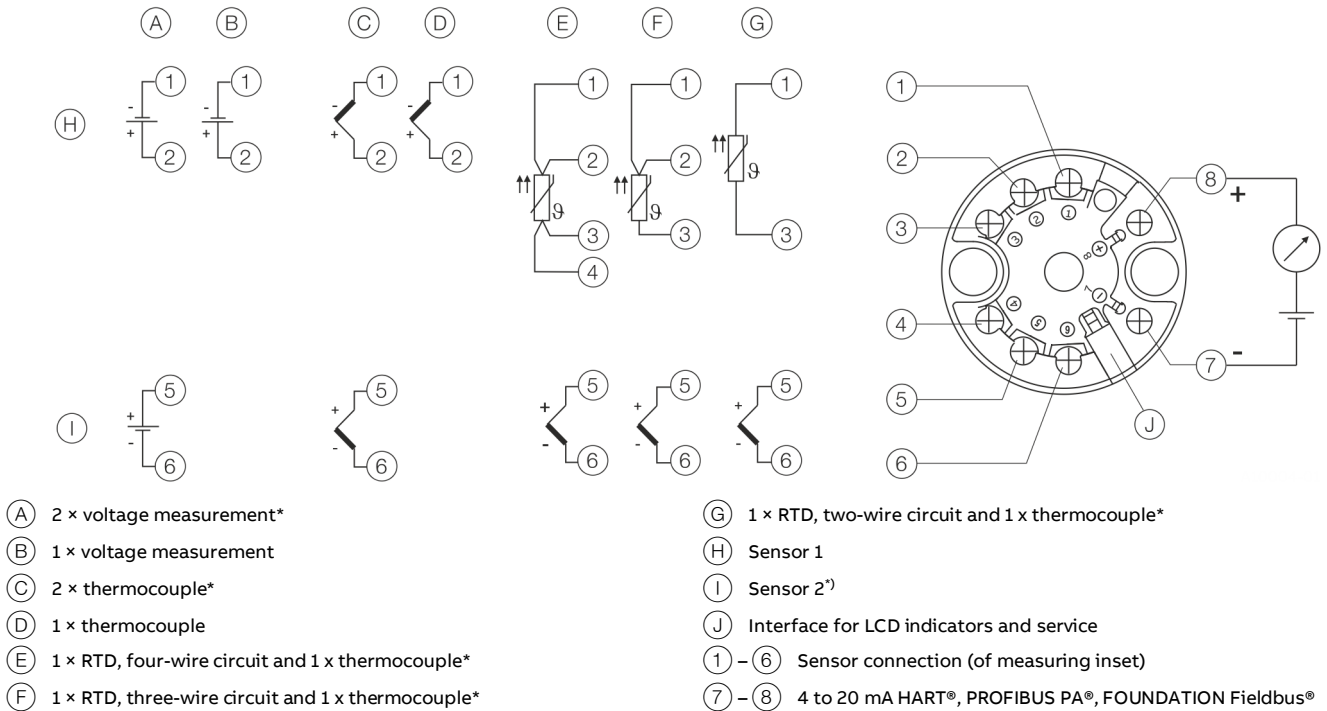

Figure 4: Terminal assignment for thermocouples / voltages and resistance thermometers (RTD) / thermocouple combinations

Communication

Configuration parameters

Measurement type

- Sensor type, connection type
- Error signaling
- Measuring range
- General information, e.g. TAG number
- Damping
- Warning and alarm thresholds
- Output signal simulation
- For details, see **Order form configuration** on page 26.

Write protection

Software write protection

Diagnostic information in accordance with NE 107

Standard:

- Sensor error signalling (wire break or short-circuit)
- Device error
- Limit value up- / down-scaled
- Upper range up- / down-scaled
- Simulation active

Advanced:

- Sensor redundancy / sensor backup active (in case sensor fails) with configurable analog alarm pulse signaling

From SW rev. 03.00:Redundancy can be configured via

Tools for:

- Increased availability (default setting for redundancy),
- Increased security,
- Increased accuracy (average value output)
- Drift monitoring
- Configurable alarm pulse signaling
- Sensor- / sensor connection lead corrosion
- Supply voltage down-scaled
- Drag indicator for Sensor 1, Sensor 2 and ambient temperature
- Ambient temperature up-scaled
- Ambient temperature down-scaled
- Operating hours counter

HART® Communication

The device is listed with the FieldComm Group.

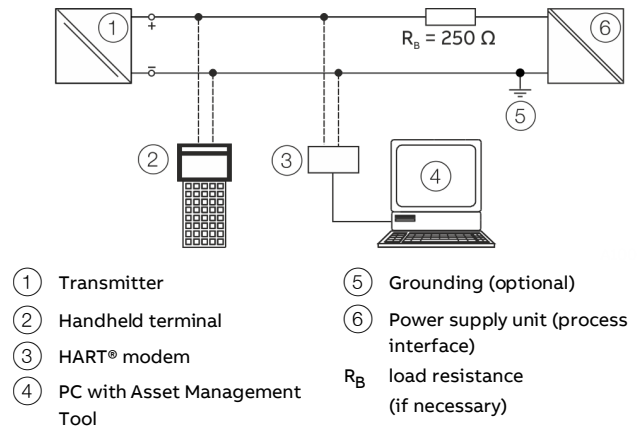

Figure 5: Example of HART® interface connection

Manufacturer ID	0x1A
Device-ID*	HART 5:0x004B (0x000B), HART 7:0x1A4B (0x1A0B)
Profile	From SW rev. 03.00 (corresponds to HW rev. 02.00 and higher): HART 5.9 and HART 7.6, can be switched via <ul style="list-style-type: none"> • HMI LCD indicator with configuration function • Tools • HART commands Default, if nothing else ordered:HART 7.6. To SW rev. 01.03: HART 5.1 and HART 7, switchable via DIP switch. Default, if nothing else ordered:HART 5.1. SW rev. 01.01.08: HART 5.1, previously HART 5.
Configuration	On device using LCD indicator DTM, EDD, FDI (FIM)
Transmission signal	BELL Standard 202

* From SW rev. 03.01.00, previously see brackets

... Communication

Operating modes

- Point-to-point communication mode – standard (general address 0)
- HART 5:Multidrop mode (addressing 1 to 15)
- HART 7:Addressing 0 to 63, independent of current loop mode
- Burst Mode

Configuration options / tools

Driver-independent:

- HMI LCD indicator with configuration function

Driver-dependent:

- Device management / Asset management tools
- FDT technology – via TTX300-DTM driver (Asset Vision Basic / DAT200)
- EDD – via TTX300 EDD driver (Handheld terminal, Field Information Manager / FIM)
- FDI technology – via TTX300 package (Field Information Manager / FIM)

Diagnosis notice

- Overrange- / underrange in accordance with NE 43
- HART® diagnosis

Extended from SW rev. 03.00:

- Device status signaling according to NE 107
- Freely configurable diagnostic categorization with diagnostic history in accordance with NE 107

Tracking of events and configuration changes, from SW rev. 03.00

The HART® device stores information on critical events and configuration changes.

The information can be output via tools:

- Event monitor for the logging of critical events
- Configuration monitor for configuration changes

For detailed information, see HART® COM/TTX300/HART interface description.

PROFIBUS PA® Communication

The interface conforms to Profile 3.01 (standard PROFIBUS®, EN 50170, DIN 1924 [PRO91]).

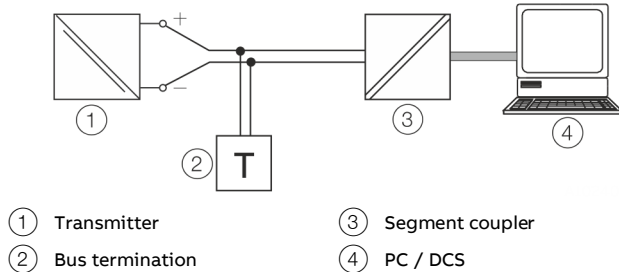

Figure 6: Example of PROFIBUS PA® interface connection

Manufacturer ID	0x1A
ID number	0x3470 [0x9700]
Profile	PA 3.01 (see PROFIBUS PA® interface description (COM/TTX300/PB))
Configuration	On device using LCD indicator DTM EDD GSD
Transmission signal	IEC 61158-2

Voltage / current consumption

- Average current consumption: 12 mA.
In the event of an error, the FDE function (= Fault Disconnection Electronic) integrated in the device makes sure that the current consumption cannot exceed a maximum of 20 mA.

FOUNDATION Fieldbus® Communication

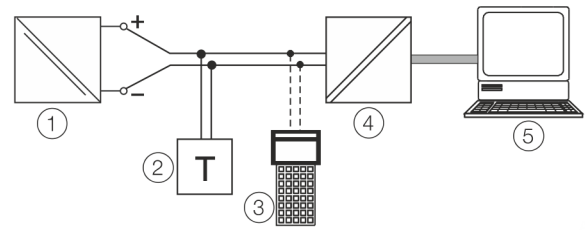

- ① Transmitter ④ Linking Device
② Bus termination ⑤ PC / DCS
③ Handheld terminal

Figure 7: Example of FOUNDATION Fieldbus® interface connection

Device ID	000320001F...
ITK	5.x (see FOUNDATION Fieldbus® interface description (COM/TTX300/FF))
Configuration	On device using LCD indicator EDD
Transmission signal	IEC 61158-2

Voltage / current consumption

- Average current consumption: 12 mA.
In the event of an error, the FDE function (= Fault Disconnection Electronic) integrated in the device makes sure that the current consumption cannot exceed a maximum of 20 mA.

Dimensions

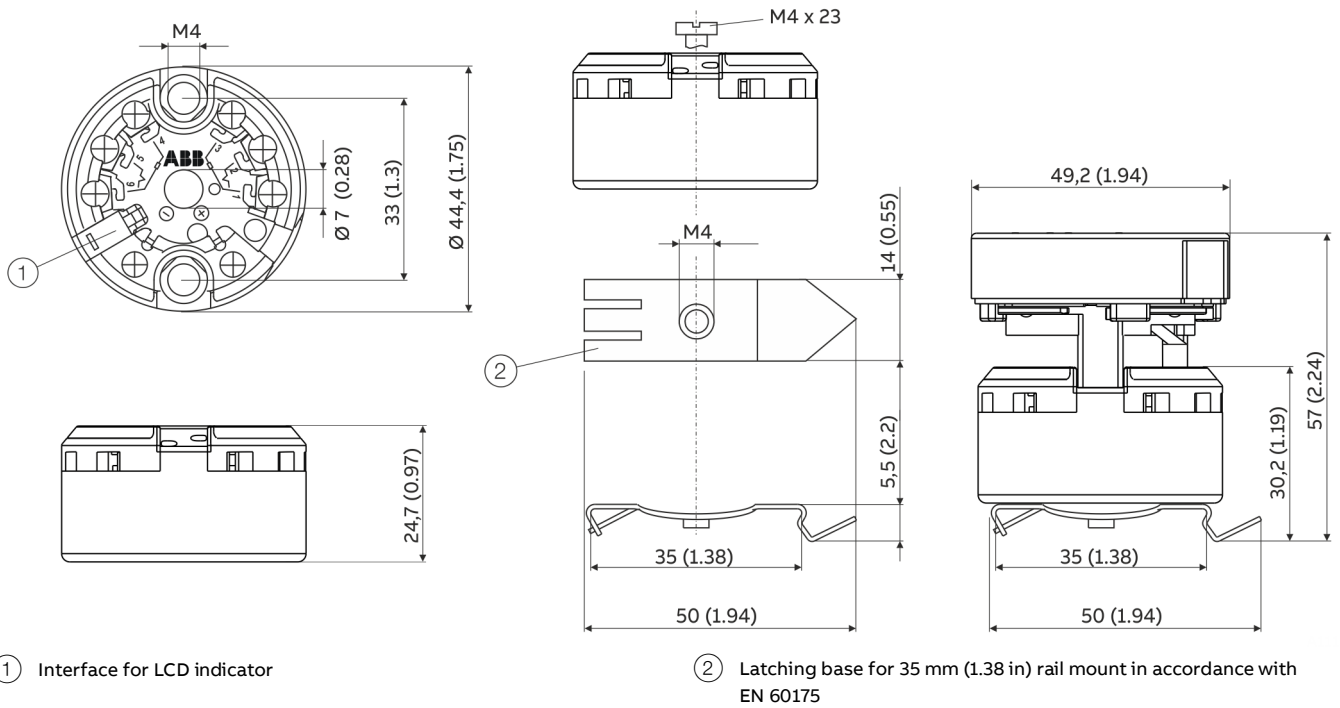

Figure 8: Dimensions in mm (in)

Use in potentially explosive atmospheres in accordance with ATEX and IECEx

Note

- Further information on the approval of devices for use in potentially explosive atmospheres can be found in the explosion protection test certificates (at www.abb.com/temperature).
- Depending on the design, a specific marking in accordance with ATEX or IECEx applies.
- A list of standards, including the output data to which the device conforms, can be found in the examination certificate or manufacturer's declaration supplied with the device.

Ex marking

Transmitter

ATEX intrinsic safety

The device fulfills the requirements of Directive 2014/34/EU in case of corresponding purchase orders and is approved for use in Zone 0, 1 and 2.

Model TTH300-E1H

To HW rev. 1.07:

Type Examination Test Certificate	PTB 05 ATEX 2017 X
From HW Rev. 02.00.00:	

Type Examination Test Certificate	PTB 20 ATEX 2008 X
-----------------------------------	--------------------

Model TTH300-E1P and TTH300-E1F

Type Examination Test Certificate	PTB 09 ATEX 2016 X
-----------------------------------	--------------------

II 1 G Ex ia IIC T6...T1 Ga

II 2 (1) G Ex [ja IIC Ga] ib IIC T6...T1 Gb

II 2 G (1D) Ex [ja IIIC Da] ib IIC T6...T1 Gb

ATEX non-sparking and increased safety

The device fulfills the requirements of Directive 2014/34/EU in case of corresponding purchase orders and is approved for use in Zone 2.

Model TTH300-E2H

To HW rev. 1.07:

Manufacturer's Declaration

II 3 G Ex nA IIC T6...T1 Gc

From HW rev. 02.00.00:

Type Examination Test Certificate	PTB 20 ATEX 2008 X
-----------------------------------	--------------------

II 3 G Ex ec IIC T6...T1 Gc

TTH300-E1P and TTH300-E1F

Manufacturer's Declaration

II 3 G Ex nA IIC T6...T1 Gc

II 3 G Ex ec IIC T6...T1 Gc

IECEx intrinsic safety

Approved for use in Zone 0, 1, and 2.

Model TTH300-H1H

To HW rev. 1.07:

IECEx certificate of conformity	IECEx PTB 09.0014X
---------------------------------	--------------------

From HW rev. 02.00.00:

IECEx certificate of conformity	IECEx PTB 20.0035X
---------------------------------	--------------------

Model TTH300-H1P and TTH300-H1F

IECEx certificate of conformity	IECEx PTB 11.0108X
---------------------------------	--------------------

Ex ia IIC T6...T1 Ga

Ex [ja IIC Ga] ib IIC T6...T1 Gb

Ex [ja IIIC Da] ib IIC T6...T1 Gb

LCD indicator

ATEX intrinsic safety

The device fulfills the requirements of Directive 2014/34/EU in case of corresponding purchase orders and is approved for use in Zone 0, 1 and 2.

Type Examination Test Certificate	PTB 05 ATEX 2079 X
-----------------------------------	--------------------

II 1G Ex ia IIC T6...T1 Ga

IECEx intrinsic safety

Approved for use in Zone 0, 1, and 2.

IECEx certificate of conformity	IECEx PTB 12.0028X
---------------------------------	--------------------

Ex ia IIC T6...T1 Ga

... Use in potentially explosive atmospheres in accordance with ATEX and IECEx

Temperature data

Transmitter

ATEX / IECEx intrinsic safety, ATEX non-sparking and increased safety

Temperature class	Permissible ambient temperature range
T6	-50 to 56 °C (-58 to 132.8 °F)
T4-T1	-50 to 85 °C (-58 to 185.0 °F)

LCD indicator

ATEX / IECEx intrinsic safety, ATEX non-sparking and increased safety

Temperature class	Permissible ambient temperature range
T6	-50 to 56 °C (-58 to 132.8 °F)
T4-T1	-50 to 85 °C (-58 to 185 °F)

Electrical data

Transmitter

Intrinsic safety type of protection Ex ia IIC (Part 1)

Supply circuit ¹⁾

	TTH300-E1H	TTH300-E1P/-H1P	
	TTH300-H1H	TTH300-E1F/-H1F	
	FISCO ¹⁾		ENTITY
Max. voltage	$U_i = 30 \text{ V}$	$U_i \leq 17.5 \text{ V}$	$U_i \leq 24.0 \text{ V}$
Short-circuit current	$I_i = 130 \text{ mA}$	$I_i \leq 183 \text{ mA}^{2)}$	$I_i \leq 250 \text{ mA}$
Max. power	$P_i = 0.8 \text{ W}$	$P_i \leq 2.56 \text{ W}^{2)}$	$P_i \leq 1.2 \text{ W}$
Internal inductance	$L_i = 160 \mu\text{H}^{3)}$	$L_i \leq 10 \mu\text{H}$	$L_i \leq 10 \mu\text{H}$
Internal capacitance	$C_i = 0.57 \text{ nF}^{4)}$	$C_i \leq 5 \text{ nF}$	$C_i \leq 5 \text{ nF}$

1) FISCO in accordance with EN 60079-27

2) II B FISCO: $I_i \leq 380 \text{ mA}$, $P_i \leq 5.32 \text{ W}$

3) Only applies to HART variants. From Hardware rev. 02.00.00, previously 0.5 mH

4) Only applies to HART variants. From hardware rev. 1.07, previously 5 nF

Intrinsic safety type of protection Ex ia IIC (Part 2)

TTH300-E1H, TTH300-H1H

Measurement current circuit

	Resistance thermometers, resistors	Thermocouples, voltages
Max. voltage	$U_o = 6.5 \text{ V}$	$U_o = 1.2 \text{ V}$
Short-circuit current	$I_o = 17.8 \text{ mA}^{1)}$	$I_o = 50 \text{ mA}$
Max. power	$P_o = 29 \text{ mW}^{2)}$	$P_o = 60 \text{ mW}$
Internal inductance	$L_i \approx 0 \text{ mH}$ (negligible)	$L_i \approx 0 \text{ mH}$ (negligible)
Internal capacitance	$C_i = 49 \text{ nF}$	$C_i = 49 \text{ nF}$
Maximum permissible external inductance	$L_o = 5 \text{ mH}$	$L_o = 5 \text{ mH}$
Maximum permissible external capacitance	$C_o = 1.65 \mu\text{F}^{3)}$	$C_o = 1.15 \mu\text{F}^{4)}$

1) From Hardware rev. 02.00.00, previously 25 mA

2) From Hardware rev. 02.00.00, previously 38 mW

3) From Hardware rev. 02.00.00, previously 1.55 μF

4) From Hardware rev. 02.00.00, previously 1.05 μF

Intrinsic safety type of protection Ex ia IIC (Part 2)
TTH300-E1P, TTH300-H1P, TTH300-E1F, TTH300-H1F

Measurement current circuit

	Resistance thermometers, resistors	Thermocouples, voltages
Max. voltage	$U_o = 6.5 \text{ V}$	$U_o = 1.2 \text{ V}$
Short-circuit current	$I_o = 25 \text{ mA}$	$I_o = 50 \text{ mA}$
Max. power	$P_o = 38 \text{ mW}$	$P_o = 60 \text{ mW}$
Internal inductance	$L_i \approx 0 \text{ mH (negligible)}$	$L_i \approx 0 \text{ mH (negligible)}$
Internal capacitance	$C_i = 49 \text{ nF}$	$C_i = 49 \text{ nF}$
Maximum permissible external inductance	$L_o = 5 \text{ mH}$	$L_o = 5 \text{ mH}$
Maximum permissible external capacitance	$C_o = 1.55 \text{ }\mu\text{F}$	$C_o = 1.05 \text{ }\mu\text{F}$

Intrinsic safety type of protection Ex ia IIC (part 3)

LCD indicator interface

Max. voltage	$U_o = 6.2 \text{ V}$
Short-circuit current	$I_o = 65.2 \text{ mA}$
Max. power	$P_o = 101 \text{ mW}$
Internal inductance	$L_i \approx 0 \text{ mH (negligible)}$
Internal capacitance	$C_i \approx 0 \text{ nF (negligible)}$
Maximum permissible external inductance	$L_o = 5 \text{ mH}$
Maximum permissible external capacitance	$C_o = 1.4 \text{ }\mu\text{F}$

Type of protection non-sparking and increased safety
TTH300-E2H from HW rev. 02.00.00

Supply circuit

Max. voltage	$U_s = 30 \text{ V}$
Rated fuse current	$I_i = 32 \text{ mA}$

**Measurement current
circuit**

Max. voltage	$U_b = 6.5 \text{ V}$
Max. output current	$I_b = 17.8 \text{ mA}$
Max. output power	$P_b = 29 \text{ mW}$
LCD indicator interface	Use not permitted

LCD indicator

Intrinsic safety type of protection Ex ia IIC

Supply circuit

Max. voltage	$U_i = 9 \text{ V}$
Short-circuit current	$I_i = 65.2 \text{ mA}$
Max. power	$P_i = 101 \text{ mW}$
Internal inductance	$L_i \approx 0 \text{ mH (negligible)}$
Internal capacitance	$C_i \approx 0 \text{ nF (negligible)}$

Use in potentially explosive atmospheres in accordance with FM and CSA

Note

- Further information on the approval of devices for use in potentially explosive atmospheres can be found in the explosion protection test certificates (at www.abb.com/temperature).
- Depending on the design, a specific marking in accordance with FM or CSA applies.

Ex marking

Transmitter

FM Intrinsically Safe

Model TTH300-L1H

To HW-Rev. 1.07:

Control Drawing SAP_214829

From HW Rev. 02.00.00:

Control Drawing See attached information

Model TTH300-L1P

Control Drawing TTH300-L1P (IS)

Model TTH300-L1F

Control Drawing TTH300-L1F (IS)

Class I, Div. 1 + 2, Groups A, B, C, D

Class I, Zone 0, AEx ia IIC T6

FM Non-Incendive

Model TTH300-L2H

To HW-Rev. 1.07:

Control Drawing 214831 (Non-Incendive)

From HW Rev. 02.00.00:

Control Drawing See attached information

Model TTH300-L2P

Control Drawing TTH300-L2P (NI_PS)

TTH300-L2P (NI_AA)

Model TTH300-L2F

Control Drawing TTH300-L2F (NI_PS)

TTH300-L2F (NI_AA)

Class I, Div. 2, Groups A, B, C, D

CSA Intrinsically Safe

Model TTH300-R1H

To HW-Rev. 1.07:

Control Drawing 214826

From HW Rev. 02.00.00:

Control Drawing See attached information

Model TTH300-R1P

Control Drawing TTH300-R1P (IS)

Model TTH300-R1F

Control Drawing TTH300-R1F (IS)

Class I, Div. 1 + 2, Groups A, B, C, D

Class I, Zone 0, Ex ia IIC T6

CSA Non-Incendive

Model TTH300-R2H

To HW-Rev. 1.07:

Control Drawing SAP_214824 (Non-Incendive)

SAP_214896 (Non-Incendive)

From HW Rev. 02.00.00:

Control Drawing See attached information

Model TTH300-R2P

Control Drawing TTH300-R2P (NI_PS)

TTH300-R2P (NI_AA)

Model TTH300-R2F

Control Drawing TTH300-R2F (NI_PS)

TTH300-R2F (NI_AA)

Class I, Div. 2, Groups A, B, C, D

LCD indicator

FM Intrinsically Safe

Control Drawing SAP_214 748

I.S. Class I Div 1 and Div 2, Group: A, B, C, D or

I.S. Class I Zone 0 AEx ia IIC T*

$U_i / V_{max} = 9 \text{ V}$, $I_i / I_{max} < 65.2 \text{ mA}$, $P_i = 101 \text{ mW}$, $C_i = 0.4 \mu\text{F}$, $L_i = 0$

FM Non-Incendive

Control Drawing SAP_214 751

N.I. Class I Div 2, Group: A, B, C, D or Ex nL IIC T**, Class I Zone 2

$U_i / V_{max} = 9 \text{ V}$, $I_i / I_{max} < 65.2 \text{ mA}$, $P_i = 101 \text{ mW}$, $C_i = 0.4 \mu\text{F}$, $L_i = 0$

CSA Intrinsically Safe

Control Drawing SAP_214 749

I.S. Class I Div 1 and Div 2; Group: A, B, C, D or

I.S. Zone 0 Ex ia IIC T*

$U_i / V_{max} = 9 \text{ V}$, $I_i / I_{max} < 65.2 \text{ mA}$, $P_i = 101 \text{ mW}$, $C_i < 0.4 \mu\text{F}$, $L_i = 0$

CSA Non-Incendive

Control Drawing SAP_214 750

N.I. Class I Div 2, Group: A, B, C, D or Ex nL IIC T**, Class I Zone 2

$U_i / V_{max} = 9 \text{ V}$, $I_i / I_{max} < 65.2 \text{ mA}$, $P_i = 101 \text{ mW}$, $C_i < 0.4 \mu\text{F}$, $L_i = 0$

* Temp. Ident: T6 T_{amb} 56 °C, T4 T_{amb} 85 °C

** Temp. Ident: T6 T_{amb} 60 °C, T4 T_{amb} 85 °C

Ordering Information

TTH300

Base model	TTH300	XX	X	X
TTH300 Head Mounted Temperature Transmitter, Pt100 (RTD), thermocouples, electrical isolation				
Explosion Protection				
Without explosion protection			Y0	
ATEX Intrinsic Safety type of protection: Zone 0: II 1 G Ex ia IIC T6...T1 Ga, Zone 1 (0): II 2 (1) G Ex [ia IIC Ga] ib IIC T6...T1 Gb, Zone 1 (20): II 2 G (1D) Ex [ia IIC Da] ib IIC T6...T1 Gb			E1	
ATEX increased safety : Zone 2: II 3 G Ex ec IIC T6...T1 Gc			E2	
IECEX Intrinsic Safety type of protection: Zone 0: Ex ia IIC T6...T1 Ga, Zone 1 (0): Ex [ia IIC Ga] ib IIC T6...T1 Gb, Zone 1 (20): Ex [ia IIC Da] ib IIC T6...T1 Gb			H1	
FM Intrinsic Safety (IS): Class I, Div. 1+2, Groups A, B, C, D, Class I, Zone 0, AEx ia IIC T6			L1	
FM Non-incendive (NI): Class I, Div. 2, Groups A, B, C, D or Class I Zone 2 Group IIC T6			L2	
CSA Intrinsic Safety (IS): Class I, Div. 1+2, Groups A, B, C, D, Class I, Zone 0, Ex ia IIC			R1	
CSA Non-incendive (NI): Class I, Div. 2, Groups A, B, C, D			R2	
GOST Russia - metrological approval			G1	
GOST Russia - metrological approval and EAC-Ex, Ex i - Zone 0			P2	
GOST Kazakhstan - metrological approval			G3	
GOST Kazakhstan - metrological approval and EAC-Ex, Ex i - Zone 0			T2	
GOST Belarus - metrological approval			M5 ¹⁾	
GOST Belarus - metrological approval and EAC-Ex, Ex i - Zone 0			U2	
NEPSI Intrinsic Safety type of protection: Ex ia IIC T6 Ga			S1	
Communication Protocol				
HART			H	
PROFIBUS PA			p ²⁾	
FOUNDATION Fieldbus			F ³⁾	
Configuration				
Standard configuration				BS
Customer-specific configuration with report, except user curve				BF ⁴⁾
Customer-specific configuration with report, including user curve				BG

1) Only available with **Communication Protocol order code H** (HART)

2) Not available with **Explosion Protection order code G1, M5**

3) Not available with **Explosion Protection order code G1, M5, U2**

4) E.g. set measuring range, TAG no.

... Ordering Information

Additional ordering information TTH300

Additional ordering information	XX	XX	XXX	XX	XX	XX	XX	XX
Declarations and Certificates								
SIL2 - Declaration of Conformity	CS*							
Declaration of compliance according EN 10204-2.1, with the order	C4							
Inspection certificate according EN 10204-3.1, visual, dimensional and functional test	C6							
Calibration Certificates								
With 5-point factory certificate		EM						
Inspection certificate according EN 10204-3.1, 5-point calibration		EP						
Handling of Certificates								
Send via e-mail			GHE					
Send via mail			GHP					
Send via mail express			GHD					
Send with instrument			GHA					
Only archived			GHS					
Extended Ambient Temperature Range								
-50 to 85 °C (-58 to 185 °F)					SE			
Field Housing								
Aluminium field housing 80 × 75 × 57 mm, IP 65, including 2 pieces M16 cable glands							H1**	
Polyester field housing 75 × 80 × 55 mm, IP 65, including 2 pieces M16 cable glands							H2**	
Polycarbonate field housing 80 × 82 × 55 mm, IP 65, including 2 pieces M16 cable glands							H3**	
Aluminium field housing 175 × 80 × 57 mm without separate terminal block, IP 65, including 2 pieces M16 and 1 piece M20 cable glands							H6**	
Polyester field housing 190 × 75 × 55 mm with separate terminal block, IP 65, including 2 pieces M16 and 1 piece M20 cable glands							H7**	
Polyester field housing 190 × 75 × 55 mm without separate terminal block, IP 65, including 2 pieces M16 and 1 piece M20 cable glands							H8**	
Display Options								
Prepared for display								D1
Not prepared for display								D2
LCD indicator type AS								D3
Configurable LCD indicator type A								D4
Mounting Options								
Snap-on fixing set for 35 mm rail acc. EN 60175 (incl. fixing screws)								SF
Customer-specific Versions								
Hardware 1.07								
Hardware 2.00								
(Please specify)								

* Only available with **Communication Protocol ordercode H (HART)**

** Not available with Explosion Protection

Additional ordering information TTH300		XXX	XX
HART version			
HART 5		C05	
HART 7		C07	
HART 5 (NE)		C15	
Documentation Language			
German			M1
English			M5
Chinese			M6
Language package Western Europe / Scandinavia (Languages: DA, ES, FR, IT, NL, PT, FI, SV)			MW
Language package Eastern Europe (Languages: EL, CS, ET, LV, LT, HU, HR, PL, SK, SL, RO, BG)			ME

Accessories	Order code
TTH / TTF300 LCD Display HMI FM Intrinsically Safe	3KXT091220L0006
TTH Snap-on fixing set (packing unit 10 pieces), for 35 mm rail acc. EN 60175 (incl. fixing screws)	3KXT091230L0001
TTH Snap-on fixing set (packing unit 1 piece), for 35 mm rail acc. EN 60175 (incl. fixing screws)	3KXT091230L0002
TTH300 Commissioning Instruction, German	3KXT231001R4403
TTH300 Commissioning Instruction, English	3KXT231001R4401
TTH300 Commissioning Instruction, Language package Western Europe / Scandinavia	3KXT231001R4493
TTH300 Commissioning Instruction, Language package Eastern Europe	3KXT231001R4494

Order form configuration

HART device design

Customer-specific configuration	Selection
Number of sensors	<input type="checkbox"/> 1 sensor (standard) <input type="checkbox"/> 2 sensors
Measurement type (for 2-sensor selection only)	<input type="checkbox"/> Sensor redundancy / sensor backup (configured for increased availability) <input type="checkbox"/> Sensor drift monitoring ____ °C / K sensor drift differential ____ s time limit for drift overshoot <input type="checkbox"/> Differential measurement: Sensor 1 - Sensor 2 <input type="checkbox"/> Differential measurement: Sensor 2 - Sensor 1 <input type="checkbox"/> Average measurement
IEC 60751 Resistance thermometer	<input type="checkbox"/> Pt10 <input type="checkbox"/> Pt50 <input type="checkbox"/> Pt100 (Standard) <input type="checkbox"/> Pt200 <input type="checkbox"/> Pt500 <input type="checkbox"/> Pt1000
JIS C1604	<input type="checkbox"/> Pt10 <input type="checkbox"/> Pt50 <input type="checkbox"/> Pt100
MIL-T-24388	<input type="checkbox"/> Pt10 <input type="checkbox"/> Pt50 <input type="checkbox"/> Pt100 <input type="checkbox"/> Pt200 <input type="checkbox"/> Pt1000
DIN 43760	<input type="checkbox"/> Ni50 <input type="checkbox"/> Ni100 <input type="checkbox"/> Ni120 <input type="checkbox"/> Ni1000
OIML R 84	<input type="checkbox"/> Cu10 <input type="checkbox"/> Cu100
	Resistance measurement <input type="checkbox"/> 0 to 500 Ω <input type="checkbox"/> 0 to 5000 Ω
IEC 60584 Thermocouple	<input type="checkbox"/> Type K <input type="checkbox"/> Type J <input type="checkbox"/> Type N <input type="checkbox"/> Type R <input type="checkbox"/> Type S <input type="checkbox"/> Type T <input type="checkbox"/> Type E <input type="checkbox"/> Type B
DIN 43710	<input type="checkbox"/> Type L <input type="checkbox"/> Type U
IEC 60584 / ASTM E988	<input type="checkbox"/> Type C
ASTM E988	<input type="checkbox"/> Type D
	Voltage measurement <input type="checkbox"/> -125 to 125 mV <input type="checkbox"/> -125 to 1100 mV
Sensor circuit (for resistance thermometer and resistance measurement only)	<input type="checkbox"/> Two-wire <input type="checkbox"/> Three-wire (standard) <input type="checkbox"/> Four-wire Two-wire circuit: Compensation of sensor line resistance max. 100 Ω <input type="checkbox"/> Sensor 1: ____ Ω <input type="checkbox"/> Sensor 2: ____ Ω
Reference junction (for thermocouples only)	<input type="checkbox"/> Internal (for standard thermocouple, except type B) <input type="checkbox"/> None (type B) <input type="checkbox"/> External / temperature: ____ °C
Meas. range	<input type="checkbox"/> Lower range value: _____ (Default:0) <input type="checkbox"/> Upper range value: _____ (Default:100)
Unit	<input type="checkbox"/> Celsius (default) <input type="checkbox"/> Fahrenheit <input type="checkbox"/> Rankine <input type="checkbox"/> Kelvin
Characteristic behavior	<input type="checkbox"/> rising 4 to 20 mA (standard) <input type="checkbox"/> falling 20 to 4 mA
Output behavior for error	
Before SW rev. 03.00:	<input type="checkbox"/> Overrange / high alarm 22 mA (default) <input type="checkbox"/> Underrange / low alarm 3.6 mA
From SW rev. 03.00:	<input type="checkbox"/> Underrange / low alarm 3.5 mA (default) <input type="checkbox"/> Overrange / high alarm 22 mA
Output damping (T ₆₃)	<input type="checkbox"/> Off (standard) <input type="checkbox"/> ____ seconds (1 to 100 s)
Sensor number	<input type="checkbox"/> Sensor 1: _____ <input type="checkbox"/> Sensor 2: _____
Resistor value at 0 °C / R ₀	Sensor 1: R ₀ : _____ Sensor 2: R ₀ : _____
Callendar-Van Dusen coefficient A	A: _____ A: _____
Callendar-Van Dusen coefficient B	B: _____ B: _____
Callendar-Van Dusen coefficient C	C: _____ C: _____
(optional, for resistance thermometers only)	
User characteristics based on linearization table	<input type="checkbox"/> Based on attached table of variate pairs
TAG number	<input type="checkbox"/> _____ (maximum 8 characters)
HART revision:	
SW rev. 01.03	<input type="checkbox"/> HART5 (default) <input type="checkbox"/> HART7
From SW rev. 03.00	<input type="checkbox"/> HART5 <input type="checkbox"/> HART7 (default)
Software write protection	<input type="checkbox"/> Off (standard) <input type="checkbox"/> On
"Maintenance required" alarm impulse	
To SW rev. 01.03	<input type="checkbox"/> Off (default) Pulse width ____ s (0.5 to 59.5 s increment 0.5 s)
From SW rev. 03.00	<input type="checkbox"/> Off (default) Pulse width (1 to 127 seconds) ____ s (increment 1 s) Pulse repetition rate (60 to 86,400 seconds / 1 day) ____ s (increment 1 s)

PROFIBUS PA® / FOUNDATION Fieldbus® Device version

Customer-specific configuration	Selection
Number of sensors	<input type="checkbox"/> 1 sensor (standard) <input type="checkbox"/> 2 sensors
Measurement type (for 2-sensor selection only)	<input type="checkbox"/> Sensor redundancy / sensor backup <input type="checkbox"/> Sensor drift monitoring ____°C / K sensor drift differential ____s time limit for drift overshoot <input type="checkbox"/> Differential measurement: sensor 1 - sensor 2 <input type="checkbox"/> Differential measurement: sensor 2 - sensor 1 <input type="checkbox"/> Average measurement
IEC 60751 Resistance thermometer	<input type="checkbox"/> Pt10 <input type="checkbox"/> Pt50 <input type="checkbox"/> Pt100 (Standard) <input type="checkbox"/> Pt200 <input type="checkbox"/> Pt500 <input type="checkbox"/> Pt1000
JIS C1604	<input type="checkbox"/> Pt10 <input type="checkbox"/> Pt50 <input type="checkbox"/> Pt100
MIL-T-24388	<input type="checkbox"/> Pt10 <input type="checkbox"/> Pt50 <input type="checkbox"/> Pt100 <input type="checkbox"/> Pt200 <input type="checkbox"/> Pt1000
DIN 43760	<input type="checkbox"/> Ni50 <input type="checkbox"/> Ni100 <input type="checkbox"/> Ni120 <input type="checkbox"/> Ni1000
OIML R 84	<input type="checkbox"/> Cu10 <input type="checkbox"/> Cu100
Resistance measurement	<input type="checkbox"/> 0 to 500 Ω <input type="checkbox"/> 0 to 5000 Ω
IEC 60584 Thermocouple	<input type="checkbox"/> Type K <input type="checkbox"/> Type J <input type="checkbox"/> Type N <input type="checkbox"/> Type R <input type="checkbox"/> Type S <input type="checkbox"/> Type T <input type="checkbox"/> Type E <input type="checkbox"/> Type B
DIN 43710	<input type="checkbox"/> Type L <input type="checkbox"/> Type U
ASTM E-988	<input type="checkbox"/> Type C <input type="checkbox"/> Type D
Voltage measurement	<input type="checkbox"/> -125 to 125 mV <input type="checkbox"/> -125 to 1100 mV
Sensor circuit (for resistance thermometer and resistance measurement only)	<input type="checkbox"/> Two-wire <input type="checkbox"/> Three-wire (standard) <input type="checkbox"/> Four-wire Two-wire circuit: Compensation of sensor-wire resistance max. 100 Ω <input type="checkbox"/> <input type="checkbox"/> Sensor 1: ____ Ω <input type="checkbox"/> Sensor 2: ____ Ω
Reference junction (for thermocouples only)	<input type="checkbox"/> Internal (for standard thermocouple, except type B) <input type="checkbox"/> None (type B) <input type="checkbox"/> External / temperature: ____°C
Unit	<input type="checkbox"/> Celsius (default) <input type="checkbox"/> Fahrenheit <input type="checkbox"/> Rankine <input type="checkbox"/> Kelvin
Resistor value at 0 °C / R ₀	Sensor 1: R ₀ : _____ Sensor 2: R ₀ : _____
Callendar-Van Dusen coefficient A	A: _____ A: _____
Callendar-Van Dusen coefficient B	B: _____ B: _____
Callendar-Van Dusen coefficient C	C: _____ C: _____
(optional, for resistance thermometers only)	
IDENT_number (PROFIBUS)	<input type="checkbox"/> device-specific 0x3470 (standard) <input type="checkbox"/> profile 0x9700 (1 AI Block)
Bus address PROFIBUS PA	<input type="checkbox"/> PA: 0 to 125 <input type="checkbox"/> Standard PA: 126
TAG number	<input type="checkbox"/> _____ (maximum 16 characters)
Software write protection	<input type="checkbox"/> Off (standard) <input type="checkbox"/> On

Trademarks

HART is a registered trademark of FieldComm Group, Austin, Texas, USA

PROFIBUS and PROFIBUS PA are registered trademarks of PROFIBUS & PROFINET International (PI)

FOUNDATION Fieldbus is a registered trademark of FieldComm Group, Austin, Texas, USA.

Sales



Service



Notes



Notes

ABB Measurement & Analytics

For your local ABB contact, visit:

www.abb.com/contacts

For more product information, visit:

www.abb.com/temperature

We reserve the right to make technical changes or modify the contents of this document without prior notice. With regard to purchase orders, the agreed particulars shall prevail. ABB does not accept any responsibility whatsoever for potential errors or possible lack of information in this document.

We reserve all rights in this document and in the subject matter and illustrations contained therein. Any reproduction, disclosure to third parties or utilization of its contents – in whole or in parts – is forbidden without prior written consent of ABB.